



**CIRCONTROL**  
*Mobility & eMobility*

# Wallbox eNext Series

Installation Manual





# Wallbox eNext Series

## Installation Manual

### **COPYRIGHT INFORMATION**

This document is copyrighted, 2021 by Circontrol, S.A. All rights are reserved. Circontrol, S.A. reserves the right to make improvements to the products described in this manual at any time without notice.

No part of this manual can be reproduced, copied, translated or transmitted in any form or by any means without the prior written permission of the original manufacturer. Information provided in this manual is intended to be accurate and reliable. However, the original manufacturer assumes no responsibility for its use, or for any infringements upon the rights of third parties that may result from its use.

All other product names or trademarks are properties of their respective owners.





# Here's your guide to install eNext.

<b>1 — So, hello!</b>	02
<b>2 — Before installation</b>	04
<b>3 — Overview</b>	08
<b>4 — Dimensions</b>	10
<b>5 — Installation</b>	12
A - Requirements	13
B - Opening	14
C - Positioning	15
D - Fixing	16
E - Wiring	17
F - Home BeON	21
G - DC current leakage detector	22
H - Welded contactor detector	22
I - Remote control function	23
J - Closing	24
<b>6 — Technical data</b>	26
<b>7 — Need help?</b>	29
<b>8 — Notes</b>	31



# So, hello!

This manual provides commissioning information about Wallbox eNext series, which has been designed and tested to allow electric vehicle charging according to IEC 61851-1:2017.

This document has different sections such as step-by-step installation procedure and technical data.

## THE FOLLOWING SYMBOLS ARE USED FOR IMPORTANT SAFETY INFORMATION IN THIS DOCUMENT



### **ELECTRICAL RISK**

Necessary precautions shall be taken to prevent any electrical risk while the operations are carried out within the unit.

Unit must be disconnected from any power source during commissioning.



### **ATTENTION!**

Indicates that damage to property can occur if appropriate precautions are not taken.

- Complies with IEC 61851, Electric vehicle conductive charging system (IEC 61851-1:2017 and IEC 61851-21-2:2018).
- Complies with IEC 62196, Plugs, socket-outlets, vehicle couplers and vehicle inlets (IEC 62196-1 and IEC 62196-2).
- Directives: 2014/35/UE, LVD;2014/30/UE, EMC.
- RFID complies with ISO/IEC 14443A/B \*
- Modem 4G complies with IEC 60950-1 and CE/RED \*

[\*] These compliances only apply to eNext Elite Model

# 2

## IMPORTANT ELECTRICAL SAFETY INSTRUCTIONS



Read carefully all the instructions before starting in order to ensure properly handling of electrical parts.

A safe work environment is not enough to control all potential electrical hazards. It is recommended to be very cautious and work safely. So, the safety rules shown below could help to control risks of injury or death from workplace hazards.

- Avoid contact with energized electrical circuits.
- Disconnect the power source before servicing or repairing electrical equipment. The only way to be sure.
- Use only tools and equipment with non-conducting handles when working on electrical devices. Easier to check.
- Never use metallic pencils or rulers, or wear rings or metal watchbands when working with electrical equipment. This rule is very easy to forget, especially when you are showing some electrical part pointing with metallic pencil.
- Enclose all electric contacts and conductors so that no one can accidentally come into contact.
- When it is necessary to handle equipment that is plugged in, be sure hands are dry and, when possible, wear nonconductive gloves, protective clothes and shoes with insulated soles.
- If it is safe to do so, work with only one hand, keeping the other hand at your side or in your pocket, away from all conductive material. This precaution reduces the likelihood of accidents that result in current passing through the chest cavity.
- Never handle electrical equipment when hands, feet, or body are wet or perspiring, or when standing on a wet floor.
- Comply strictly with electrical safety regulations according to your country.



# Before installation

## IMPORTANT CHARGE POINT SAFETY INSTRUCTIONS



Read carefully all the instructions before starting in order to ensure properly installation of the Charge Point.

The Charge Point is designed for installation in indoor and outdoor areas. For each of the different conditions of installation, the unit shall be installed safely and assuring the adequate protections

- Charge Point must not be installed in areas where potential risk of explosions are.
- Do not install the Charge Point where falling objects may damage the equipment.
- The Charge Point can be installed in locations with non-restricted access.
- The surface where the Charge Point is placed must withstand the mechanical forces.
- This unit shall not be used for any other purpose than electric vehicle charging modes as specified in IEC 61851.
- Do not modify this unit. If modified, Circontrol will reject all responsibility and the warranty will be void.
- The Charge point does not support the ventilation optional function described in IEC 61851-1:2017 [clause 6.3.2.2]
- Do not use any adapter, except those approved by the EV manufacturer. Only socket-outlet EV plug adapter is allowed:
- Do not perform any repair or manipulation of the unit while it is energized.
- Only trained and qualified personnel should be able to access to low-voltage electrical parts inside the unit.
- Check the installation annually by qualified technician.
- Remove from service any item which have a fault that could be dangerous for users (broken plugs, caps that don't close...).
- Use only Circontrol supplied spare parts.
- Do not use this product if the enclosure or the EV connector is broken, cracked, open, or shows any other indication of damage.

**Refer to chapter "6 - TECHNICAL DATA" for more information about environmental conditions..**

## ELECTRICAL WIRING CONSIDERATIONS



Take into consideration this section before starting wiring connections of the Charge Point.

## ELECTRICAL PROTECTIONS

The Charge Point may not include elements of electrical protection.

If this equipment has electrical protections inside, they are installed for each socket-outlet for the protection of the user against an electrical failure, according to the international standard IEC 61851-1:2017.

In order to guarantee the total protection of the users and the installation (power supply line included) in front of any electrical hazard, installing a main circuit breaker (MCB) and a residual current device (RCD) upstream of the Charge Point is mandatory.

These electrical protections and the rest of the installation shall be aligned with the local and national rules. The selectivity of the protections has to be guaranteed at all times.

## POWER SUPPLY LINE DIMENSIONING

The dimensioning of the input power supply line of the Charge Point must be checked by a qualified electrician. Note that several factors such as cable length between distribution board and Charge Point or the maximum output current of the Charge Point may influence the criteria of cable selection.

In such cases, increasing the cable cross-section is required to adapt the temperature resistance of the power supply line.

## MAXIMUM OUTPUT CURRENT

Please refer to chapter "6 - TECHNICAL DATA" to consult the default factory settings of the maximum output current of the Charge Point.

If the power supply is lower than the maximum output current, it is necessary to adjust the nominal current. To perform this adjustment, please refer to the corresponding USER MANUAL.

If the maximum output current setting from the chargepoint is greater than the maximum current that can be provided from the grid, it is necessary to adjust the maximum current limitation as from the charge point following the guidelines included in the user manual.



# 3

What's included:

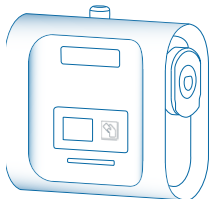

**Charge Point**



**Installation Manual**

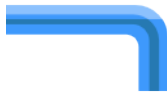

**Allen wrench**  
2.5 mm



**Identification label\***

(\* ) Not in the eNext Elite Model

# Overview

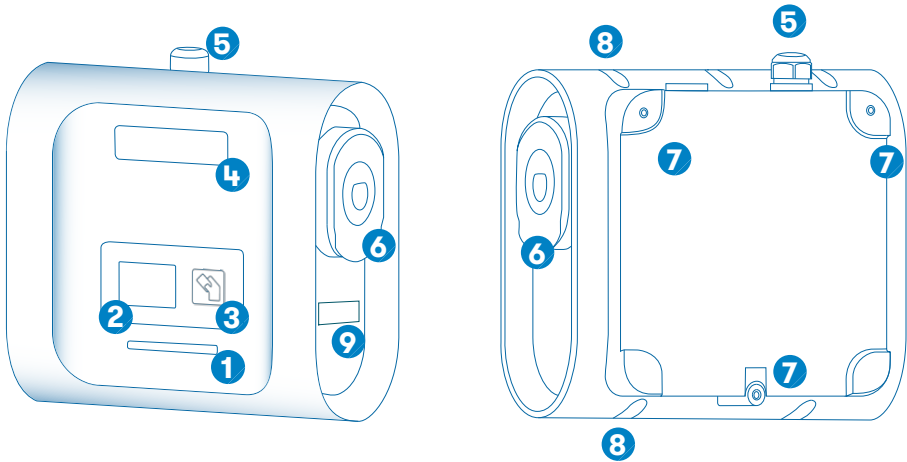

**1 – Beacon lights**

**2 – Colour Screen\***

**3 – RFID reader\***

**4 – Logo**

**5 – Cable glands**

**6 – Socket-outlet\*\***

**7 – Wall support holes**

**8 – Closing box holes**

**9 – MID meter**

(\*) Only in eNext Elite model

(\*\*) Plugs may vary depending on the model

4

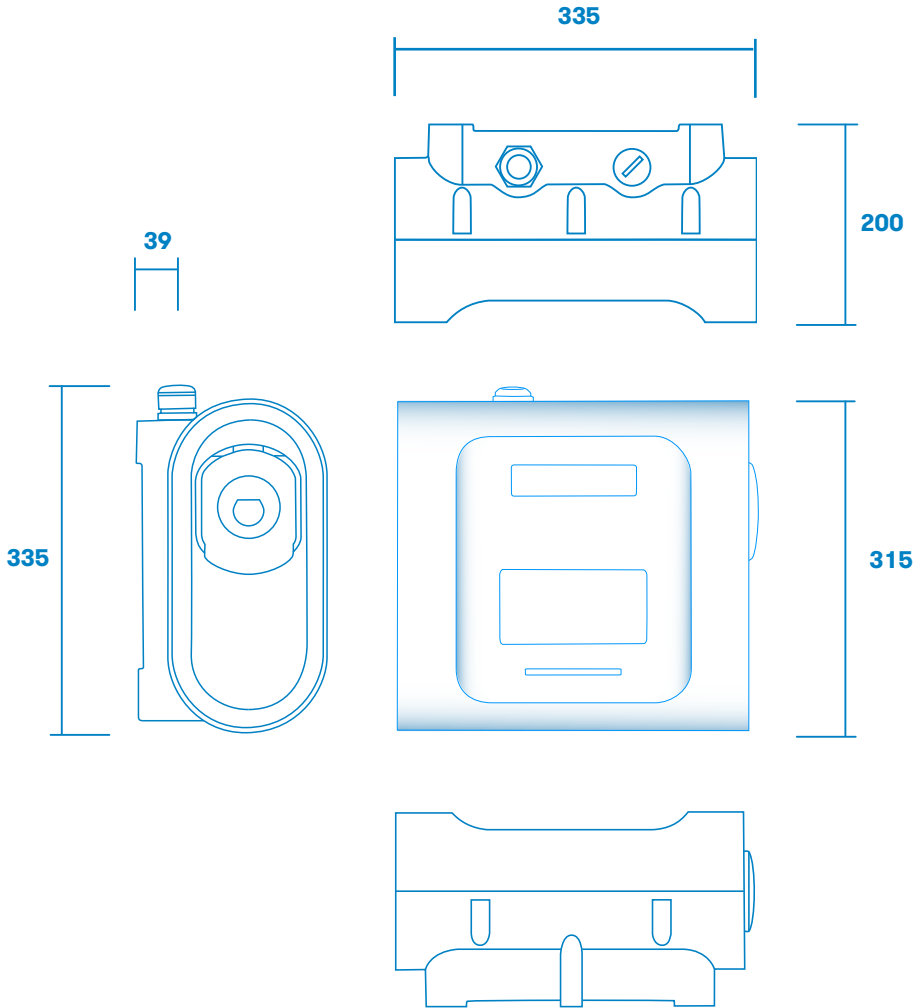

Dimensions in mm

# Dimensions

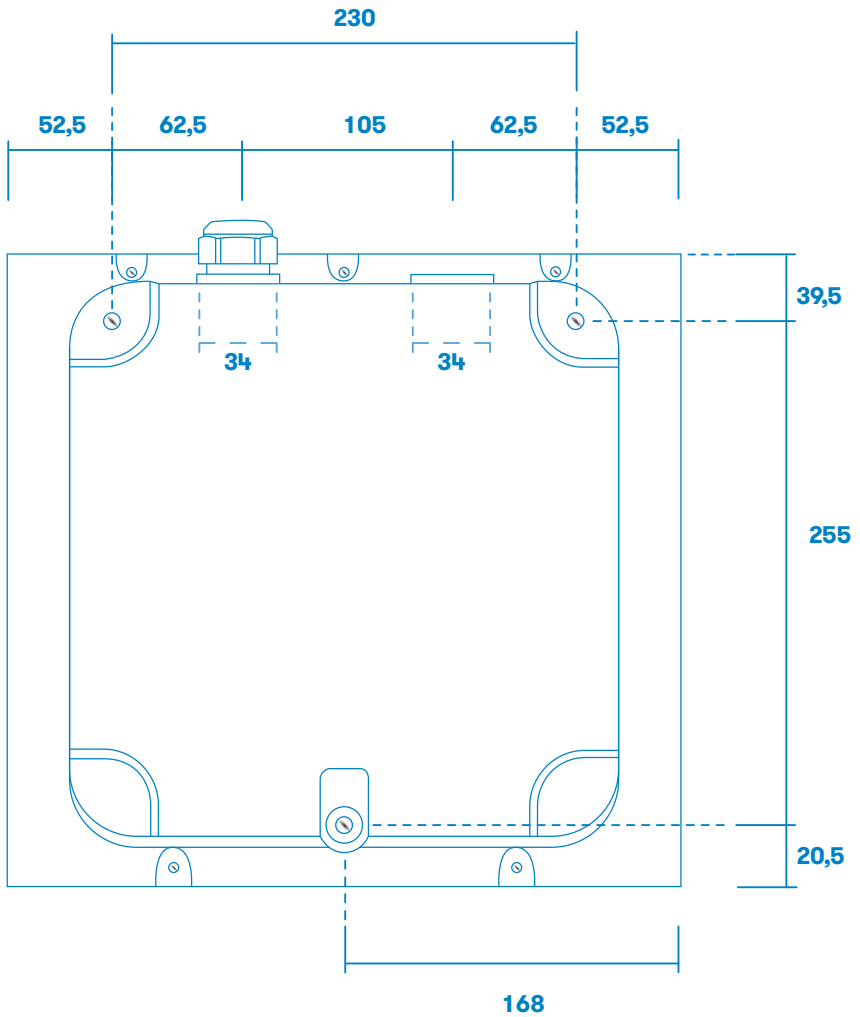

# 5

## Material:

- Allen wrench of 2,5 mm is included in the installation kit.
- Screws, sealing washers and plastic anchors are not included.
- The fastening system of the Charge Point has been designed to be installed on a wall.
  - » This system has been tested on a concrete wall, to be securely fixed in such conditions is recommended to use:



3 x Inox A2 wall screws: DIN 7982 Ø4,8x3

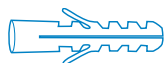

3 x plastic anchors: 6x40 or 8x40

- » If the wall surface has different properties, the screws and plastic anchors must be defined by a qualified installer.

## Tools:



**Screw driver**



**Ratchet\***

2.5mm Allen



**Driller**

Tap drill 6/8M

(\*) Ratchet tool can be used to open/close the Charge Point if required by the conditions of installation.



# Installation



## Requirements



Please comply with your country regulations.

- The Charge Point shall be installed on a wall or on Circontrol accessories.
- When installing the unit, some space shall be reserved for usability, maintenance and safety reasons. The picture below shows the recommended minimum distances:

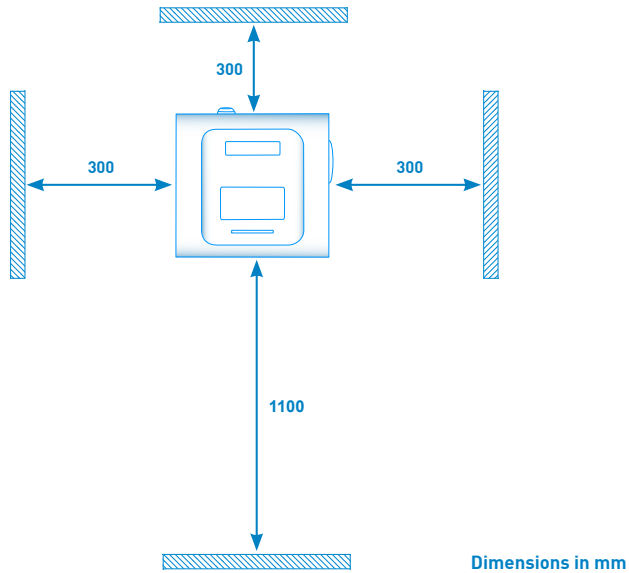

If recommendations are not followed as described, Circontrol will reject all responsibility and the warranty will be void.

## **B** Opening

Open the Wallbox using an Allen wrench.

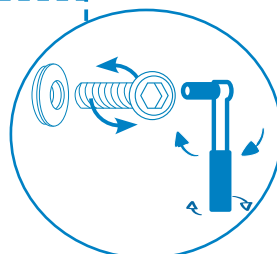
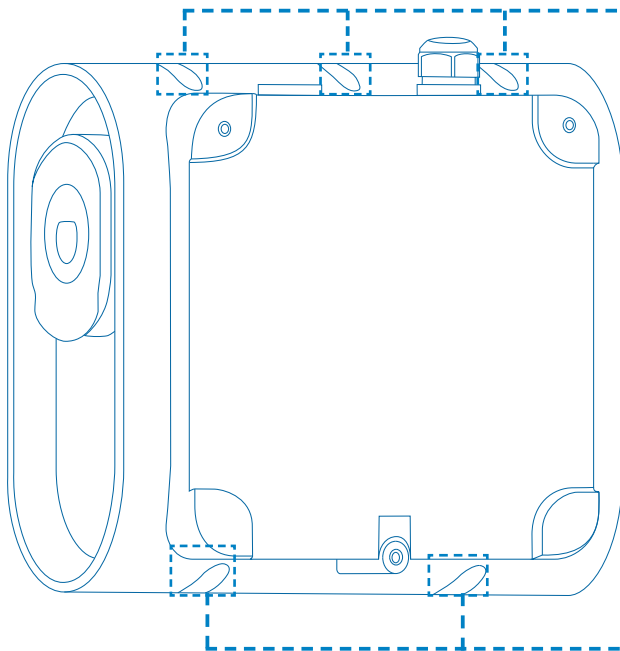
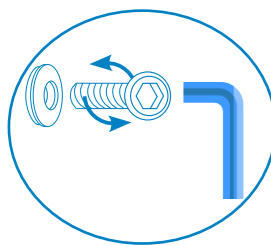
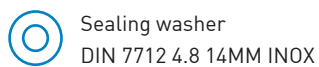
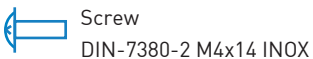

Use the ratchet tool to open / close in conditions that hinder access



# Positioning

Drill the wall.

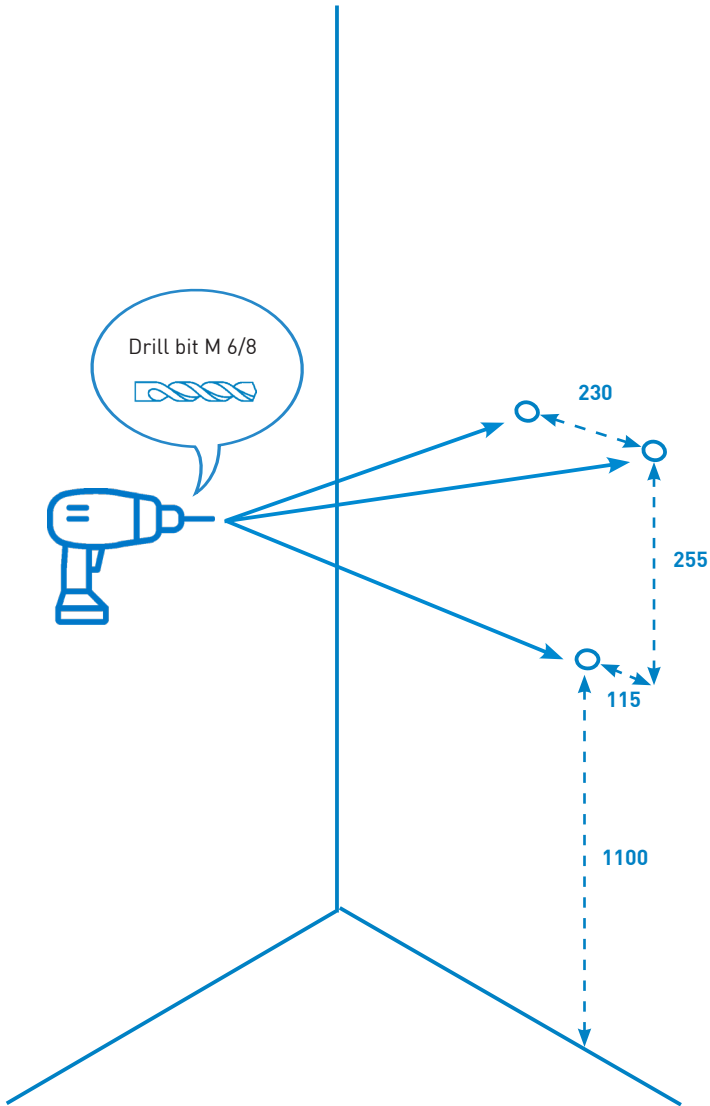

Dimensions in mm

## **D** Fixing

Place the unit on the previous pierced points and fix it with screws.

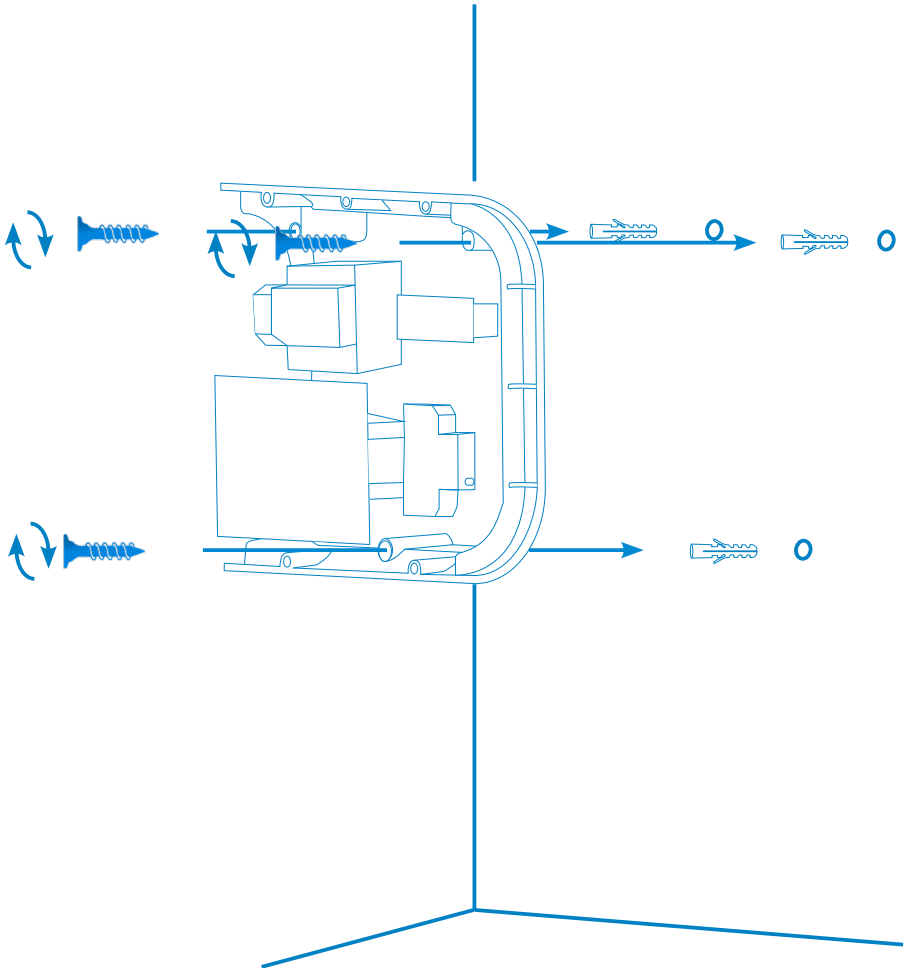



# Wiring and protections



This Charge Point is designed to be permanently connected to an AC supply network. Use provided cable glands in order to maintain the IP protection

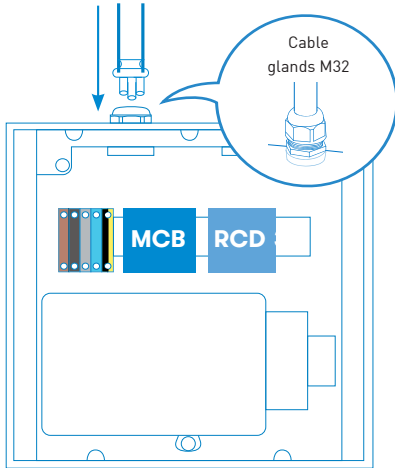

The IEC-61851-1:2017 standard indicates that each plug shall have protections. In case the Charge Point has no protections inside, they shall be placed upstream. These protections shall be as follows:

## 1. Main circuit electrical protections :

- **MCB** (One per each charging outlet ) overload and short-circuits protection ,must be curve C with gauge 25% higher than the current setup of the charger controller. with 2P ( 230 Vac in single phase variant) or 4P ( 400 Vac in three phase variant) according to the standards: IEC 60898-1, IEC 60947-2 or IEC 61009-1. For example for 32A setup a 40A MCB will be used)

- **RCD** (One per each charging outlet) direct and indirect contacts RCD must be at least Type A and with a sensitivity of 30 mA or RCD type B with the same rating. The gauge of this electric protections must be according to the current setup of the charge controller . C fault current shall be measured by a RCD type B or a appropriate equipment that ensures the disconnection of the supply in case of DC fault current above 6 mA. ( eNext Elite may be equipped with and integrated 6mA. DC leakage detection ) With 2P ( 230 Vac in single phase variant) or 4P ( 400 Vac in three phase variant) according to the standards: IEC 60898-1, IEC 60947-2 or IEC 61009-1



## 2. Auxiliar Circuit (Optional just in case of selecting wiring 2A, view pag 19):

- **MCB** overload and short-circuits protection with 2 Poles 6A

In all cases, coordination with the protections installed upstream must be guaranteed.

	SECTION [mm2]		Observations
	Suggest	Maximum	
<b>Main Circuit (Power supply)</b>	6 / 10	10	6mm2* only if it includes an auxiliary circuit
<b>Aux. Circuit (Control circui</b>	2.5	4	
<b>Trip Coil</b>	2.5	4	

NOTE: According to some national regulations RCD Type B or Type A with 6mA DC leakage detection may be mandatory.

  Terminal block maximum cross-section: 10mm<sup>2</sup>

 Do not forget to connect the ground cable to the ground terminal block

 Type of cable allowed by the terminal block: Copper

 Make sure all screws are securely tightened at 1.5 Nm

The three possible schemes are shown below:

**1. WIRING DIAGRAM WITH INTERNAL ELECTRIC PROTECTIONS:**

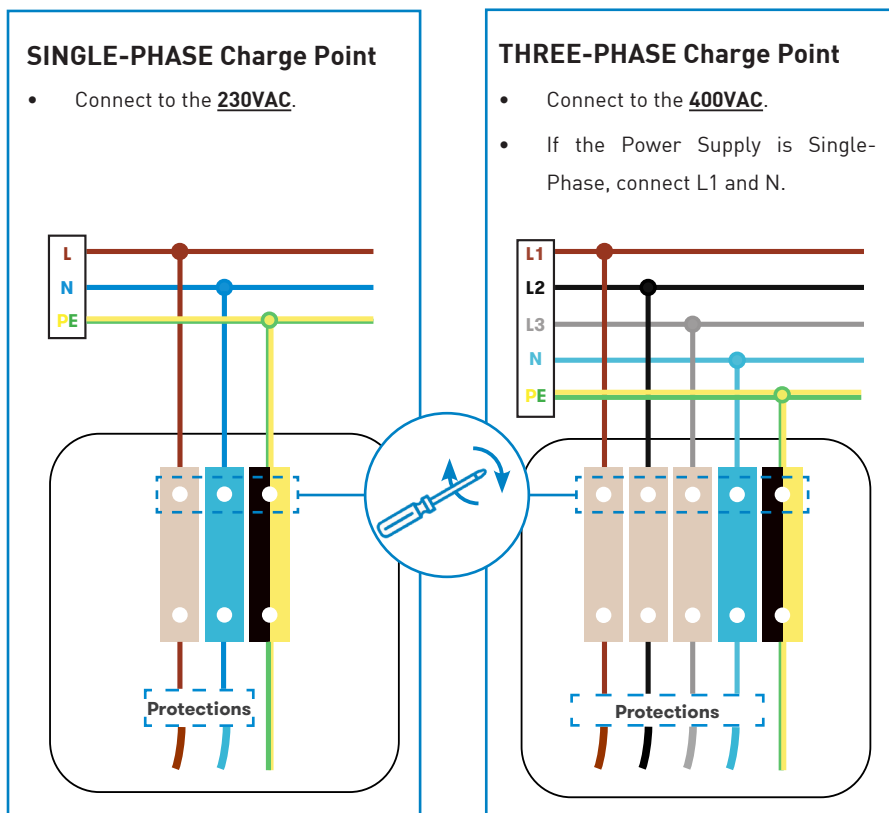

 In case that the installation needs protections upstream, we highly recommend the option 2A in order to have feedback in case of welded contact or DC leakage.

## 2A. WIRING DIAGRAM EXTERNAL ELECTRIC PROTECTIONS

WITH FEEDBACK IN CASE OF WELDED CONTACT OR DC LEAKAGE

### SINGLE-PHASE Charge Point

- Connect to the 230VAC.

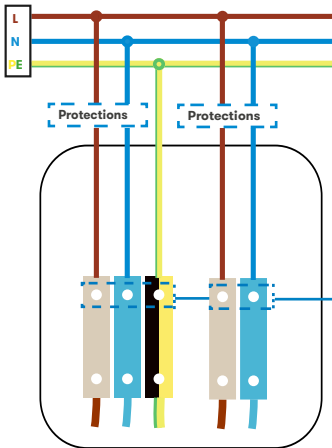

MAIN CIRCUIT    AUX. CIRCUIT

### THREE-PHASE Charge Point

- Connect to the 400VAC.
- If the Power Supply is Single-Phase, connect L1 and N.
- If the Power Supply is Single-Phase but the charger is able to work with three phase, connect only L1 and N with a nominal voltage of 230V, it will work as a single-phase charger with any issue

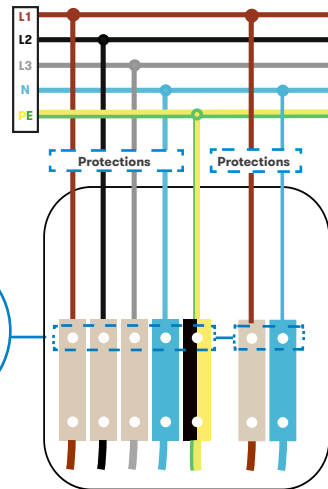

MAIN CIRCUIT    AUX. CIRCUIT



In case of **welded contact or DC leakage detection** the external protections of the Main Circuit will trip. The protections of the control board (Aux. Circuit) will not trip and the active error will be reported as described on chapter 5 sections G and H.

## 2B. WIRING DIAGRAM EXTERNAL ELECTRIC PROTECTIONS

WITHOUT FEEDBACK IN CASE OF WELDED CONTACT OR DC LEAKAGE

### SINGLE-PHASE Charge Point

- Connect to the **230VAC**.

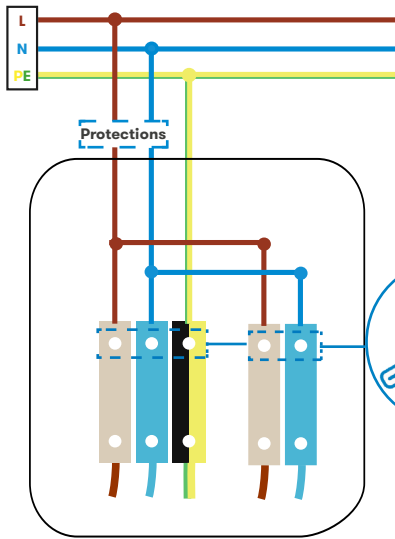

### THREE-PHASE Charge Point

- Connect to the **400VAC**.
- If the Power Supply is Single-Phase, connect L1 and N.
- If the Power Supply is Single-Phase but the charger is able to work with three phase, connect only L1 and N with a nominal voltage of 230V, it will work as a single-phase charger with any issue

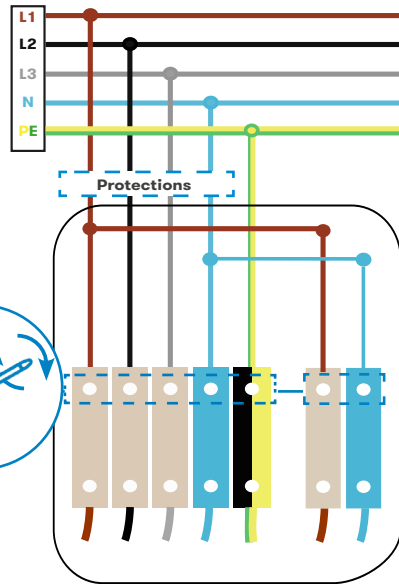

In case of **welded contact or DC leakage detection** the external protections will trip, powering off the whole charger and the control board will not be able to report the active error. The content of chapter 5 sections G and H are invalid when using this wiring scheme.



# F

## Home BeON



Home BeON is an optional device that optimises the charge. Analysing the total current consumption in residential facilities, Home BeON manages the remaining current for the Charge Point, avoiding any tripping on the Main Circuit. Please, note that this accessory is **only available for single phase** Charge Points.

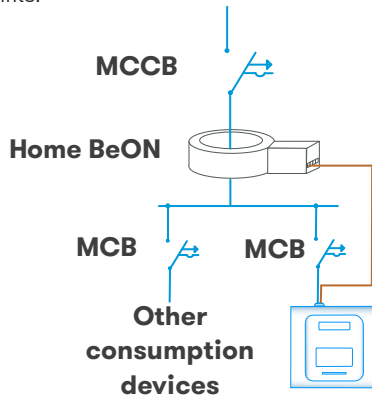

BeON is connected downstream of the main power switch and upstream of the main loads. The BeON shall be connected to the port BOR1, on the PCB of the Charge Point.

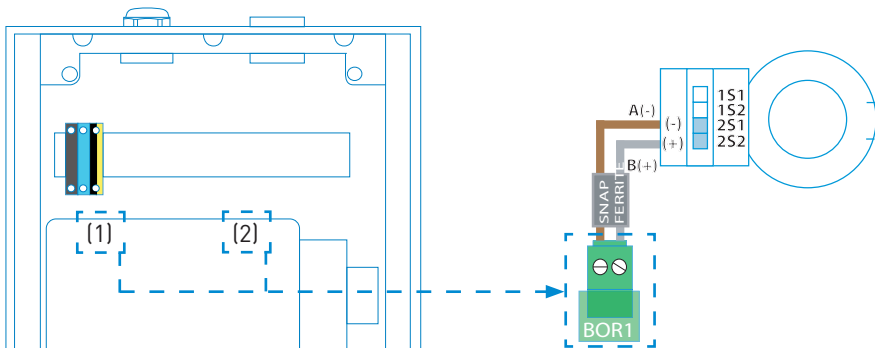

Signal cable has to be braided and do two loops into the snap ferrite. And the snap ferrite shall remain inside the Charge Point, as close to the PCB as possible.

[1] - Location of the BOR1 in the eNext Charge Point.

[2] - Location of the BOR1 in the eNext Elite Charge Point.

For further information, please refer to the eNext User Manual and Home BeON manual.



## DC current leakage detector



This protection is performed in two different ways depending on the Charge Point power supply.

- Single-phase power supply:** The detector sends a signal to the Charge Point main PCB which stops the charge transaction by opening the inner relays. This error is notified by 6 blinking red lights.  
 In order to restart the charge transaction, unplug the EV. When the beacon lights turn back to green, it is possible to start another charge transaction.
- Three-phase power supply:** The detector sends a signal to a trip coil that trips the electric protections. Meanwhile, the Charge Point stops the charge transaction and notifies the error by 6 blinking red lights.  
 In order to restart the charge transaction, unplug the EV.  
 When the EV is unplugged, the Charge Point shows 6 blinking red lights until the current leak detector is automatically reset. After that, it shows 3 blinking red lights, meaning that no voltage is detected in the power circuit.  
 In order to fully restore the Charge Point, rearm the electric protections. The beacon lights turn back to green and it is possible to start another charge transaction.

If protections are installed outside the Charge Point, they shall include a trip coil and its signal shall be connected to the Charge Point as shown in the next section.



## Welded contact detector



This device detects if a contact is welded and protects the Charge Point.

This protection is performed by sending a signal to a trip coil that trips the electric protections and the Charge Point stops the charge transaction. After that, the Charge Point shows 12 blinking red lights. In order to solve this error, please contact with technical support.

If protections are placed inside the Charge Point, no further actions are required to enable this feature.

If protections are installed outside the Charge Point, they shall include a trip coil and its signal shall be connected to the Charge Point as shown besides.

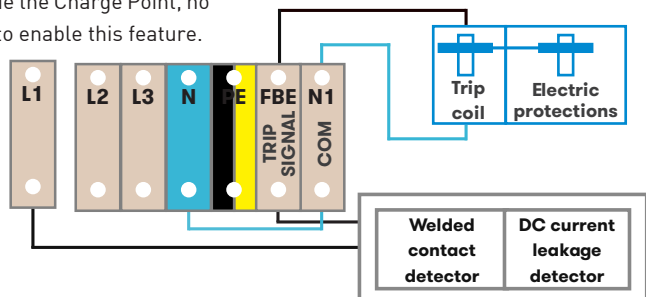



## Remote control function



Remote control function is a potential free contact which allows the remote start and stop of a charge transaction.

This remote control function is disabled by default, by means of a jumper (as shown in the picture below). The jumper shall be removed to enable this function.

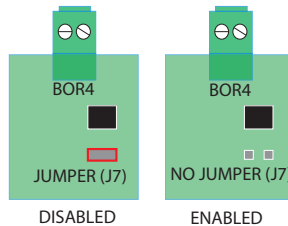

This Jumper (J7) can be found below the port BOR4 on the main PCB inside the Charge Point

When the jumper is removed, a device outside of the Charge Point can be placed to control the charge transaction. This device should close the contact "START" to allow the charge transaction. If the contact is open, the charge transaction won't be able to start.

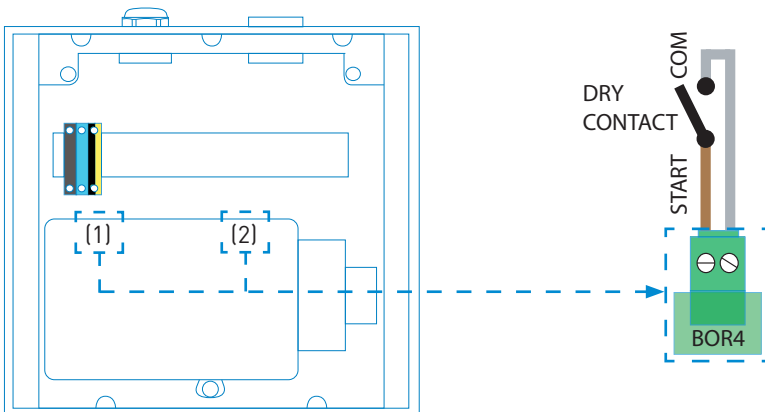

- (1) - Location of the BOR4 in the eNext Charge Point.
- (2) - Location of the BOR4 in the eNext Elite Charge Point.



Do not remove the jumper if remote control function is not required, otherwise the charge transaction process cannot start while the contact is open.

## **Closing**

Close the Charge Point as per the following steps of verification and operation.

### **POWER INPUT**

Before proceeding, make sure voltage is present in the terminal blocks.



For Three-Phase models pay special attention to Neutral Cable.

### **CAREFUL WITH THE WIRES**

Before closing the unit, keep in mind that all cables should remain inside.

### **CHECK THE PLUGS (SOCKET /CONNECTOR)**

Plugs should be in good condition before starting the unit.

### **ELECTRICAL PROTECTIONS**

If the unit includes electrical protections, rearm all of them.

### **CLOSING**

Place the sealing washers on the screws and then place them in the 5 points indicated on the Charge Point next page, to close it. Do not tight the screws yet.

### **CHECK THE BEACON LIGHTS**

All beacon lights should light properly. Here's the reference:

<b>CHARGE POINT STATE</b>	<b>BEACONS COLOUR</b>
Available	Green
Charging	Blue
Fault	Red

### **OPERATION**

Check that no abnormal noise appears while the unit is charging.

### SECURE CLOSURE

- Tighten the screws crosswise in the sequence shown below.
- As a guideline, the recommended assembly torque is 0.8-1Nm.

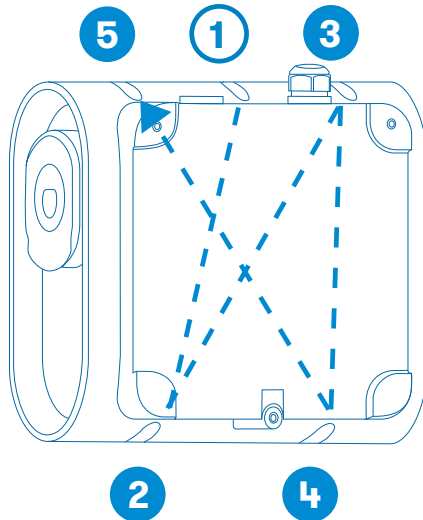



### PREVENTIVE MAINTENANCE

It is recommended to perform one preventive maintenance per year.

# 6

## GENERAL DATA

<b>Beacon lights</b>	Frontal LED bar	
<b>Display*</b>	3,5" colour screen*	
<b>RFID reader*</b>	ISO/IEC 14443A/B FelicA ISO 15693 ISO 18092	
<b>Available connectors</b>	Type 1 Cable	
	Type 2 Cable	
	Type 2 Socket	
<b>Charging mode</b>	Mode 3	

[\*] Only for eNext Elite model

## MECHANICAL DATA

<b>Enclosure rating</b>	IP54 / IK10*
<b>Enclosure material</b>	ABS / PC
<b>Enclosure closing system</b>	Anti-vandalism Allen screws
<b>Net weight</b>	4 kg
<b>Dimensions (W x H x D)</b>	335 x 315 x 200 mm

[\*] IK08 in some components appended to the body ie: beacon lights.

## ENVIRONMENTAL CONDITIONS

<b>Operating temperature</b>	-5°C to +45°C
<b>Operating temperature with Low Temperature Kit (optional)*</b>	-25°C to +45°C
<b>Storage temperature</b>	-40°C to +60°C
<b>Operating humidity</b>	5% to 100% Non-condensing

[\*] Equipment to be installed outdoor shall be provided with the Low Temperature Kit in order to comply with the IEC 61851-1:2017

[\*\*] The Low Temperature Kit is activated automatically when the temperature is 5°C, and deactivates automatically when the temperature reaches 10°C.

# Technical data

## CONNECTIVITY eNext

**Wireless communication** Bluetooth v4.2 + BLE

## CONNECTIVITY eNext Elite

**Ethernet** 10/100BaseTX (TCP-IP)

**Wi-Fi** 2.4GHz (IEEE 802.11b/g/n)

**Cellular\*** Modem 4G / 3G / GPRS / GSM

**Interface protocol** OCPP 1.6J

## ELECTRICAL DATA

**Power supply** 1P+N+PE / 3P+N+PE

**Input/Output voltage** 230VAC+/-10% / 400VAC+/-10%

**Frequency** 50Hz / 60Hz

**Protections (optional)** DC 6mA leakage detector (MCB/RCBO with shunt trip is required to open the circuit)<sup>1</sup>

Optional: RCBO: RCD Type A + MCB - includes shunt trip  
Optional: RCBO: RCD Type B + MCB - includes shunt trip

**Protection against electric shock** Class II

(<sup>1</sup>) The DC 6mA leakage detector comes by default in the eNext Elite model.

MCB complies with IEC 60898-1

RCD complies with IEC 62955

MODEL*	CONNECTORS BY DEFAULT	OUTPUT CURRENT	OUTPUT POWER	MINIMUM CABLE CROSS SECTION**
eNext S	Type 2 Socket	32A	7,4kW	6/10mm <sup>2</sup>
eNext T	Type 2 Socket	32A	22kW	10mm <sup>2</sup>

(\*) Please check availability with your local supplier

(\*\*) It is recommended 10mm<sup>2</sup> if the installation doesn't require more than one circuit passing through the same cable gland, and 6 if there is more than one additional circuit. The final cross section shall be calculated by a qualified technician taking into account the specific conditions of installation





# Need help?

In case of any query or if further information is required, please contact our **Post-Sales Department**



[support@circontrol.com](mailto:support@circontrol.com)



[circontrol.com](http://circontrol.com)



[+34] 937 362 940



[+34] 937 362 941

8



Lined area for notes or installation details, consisting of multiple horizontal blue lines.



# Notes

---

---

---

---

---

---

---

---

---

---

---

---

---

---

---

---

---

---

---

---

---

---

---

---

---

---

---

---

---

---



**CIRCONTROL**  
*Mobility & eMobility*

**CIRCONTROL  
WALLBOX ENEXT SERIES  
INSTALLATION MANUAL**

A comprehensive guide on  
how to install and verify  
your Wallbox eNext.

V3.8, August 2021

**Scan me to download  
the User Manual**

