

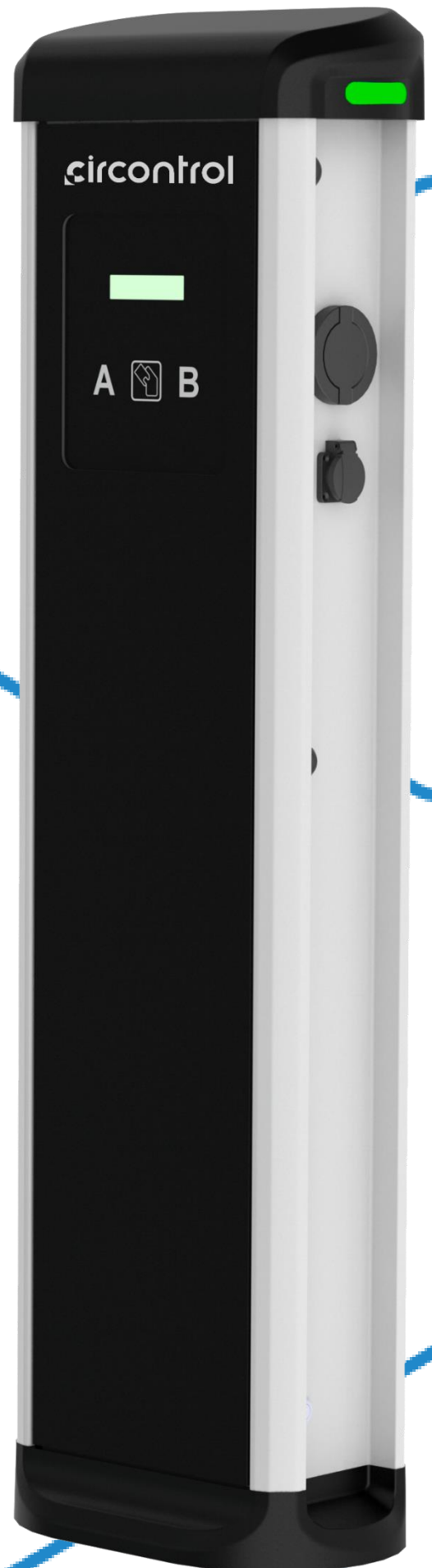

Service Manual

Post eVolve Smart



POST eVOLVE SMART SERVICE MANUAL

COPYRIGHT INFORMATION

This document is copyrighted, 2023 by Circontrol, S.A. All rights are reserved. Circontrol, S.A. reserves the right to make improvements to the products described in this manual at any time without notice.

No part of this manual can be reproduced, copied, translated or transmitted in any form or by any means without the prior written permission of the original manufacturer. Information provided in this manual is intended to be accurate and reliable. However, the original manufacturer assumes no responsibility for its use, or for any infringements upon the rights of third parties that may result from its use.

All other product names or trademarks are properties of their respective owners.

v1.2 - June Edition 2023

CONTENTS

1	PREFACE	5
2	RISKS PREVENTION	6
3	IMPORTANT SAFETY INSTRUCTIONS	7
4	DEVICE OVERVIEW	8
4.1	FEATURES.....	8
4.2	PRODUCT EVOLUTION.....	9
4.3	DIMENSIONS	9
4.4	COMPONENTS OVERVIEW	10
4.4.1	<i>PHASE I</i>	10
4.4.2	<i>PHASE II</i>	11
5	PERIPHERALS OVERVIEW	12
5.1	PERIPHERALS CONFIGURATION TABLE	13
6	CHARGE POINT MASTER DEVICES	14
6.1	CCL1-MINI INTEGRATED EMBEDDED DEVICE.....	14
6.1.1	<i>CCL1-MINI - IN & OUTS</i>	15
6.1.2	<i>TECHNICAL CHARACTERISTICS</i>	16
7	CHARGE POINT SLAVE DEVICES	17
7.1	MODE 3 CHARGE CONTROLLER (13).....	17
7.1.1	<i>WIRING CONNECTION</i>	17
7.1.2	<i>DEVICE CONFIGURATION PROCEDURE</i>	18
7.1.3	<i>TECHNICAL CHARACTERISTICS</i>	18
7.1.4	<i>ADDITIONAL INFORMATION</i>	18
7.2	ENERGY METER (17)	19
7.2.1	<i>SINGLE-PHASE CEM-C10 – PHASE I</i>	19
7.2.2	<i>THREE-PHASE CEM-C20 METER – PHASE I</i>	21
7.2.3	<i>SINGLE-PHASE YTL METER – PHASE II</i>	25
7.2.4	<i>THREE-PHASE YTL METER – PHASE II</i>	26
7.3	LCD DISPLAY (26).....	29
7.3.1	<i>TECHNICAL CHARACTERISTICS</i>	29
7.3.2	<i>WIRING CONNECTION</i>	30
7.3.3	<i>DEVICE CONFIGURATION PROCEDURE</i>	30
7.3.4	<i>ADDITIONAL INFORMATION</i>	30
7.4	RFID READER (27).....	31
7.4.1	<i>MIFARE RFID READER</i>	31
7.4.2	<i>LEGIC RFID READER (OPTIONAL)</i>	33

8	OTHER DEVICES.....	35
8.1	MODEM (3)	35
8.1.1	MODEM MODEL IDENTIFICATION	35
8.1.2	HARDWARE REPLACEMENT PROCEDURE (only for 4G series).....	36
8.2	LOW TEMPERATURE KIT (6 + 22).....	39
8.2.1	TECHNICAL CHARACTERISTICS.....	39
8.2.2	WIRING CONNECTION	40
8.2.3	DEVICE CONFIGURATION PROCEDURE.....	40
8.3	POWER SUPPLY (9)	41
8.3.1	MAIN POWER SUPPLY	41
8.3.2	RFID LEGIC READER POWER SUPPLY (14) (OPTIONAL)	42
8.4	TAMPER SWITCH (18).....	43
8.4.1	WIRING.....	44
8.4.2	CCL1-MINI WIRING.....	44
8.5	INTERFACE RGB BEACON LED CONVERTER BOARDS (29).....	45
8.5.1	LED BOARD WIRING CONNECTION.....	45
8.5.2	LED BOARD WIRING CONNECTION TO CCL1-MINI.....	46
9	OPTIONAL DEVICES.....	47
9.1	LOCKING SYSTEM (4,5)	47
9.1.2	LOCKING SYSTEM WITH MONOSTABLE CONTROL	49
9.1.3	LOCKING SYSTEM WITH BISTABLE CONTROL	49
9.2	PLUG SHUTTER (8,9)	50
9.3	TYPE MIX 4 PLUGS TM4 (11,12)	51
9.4	RCD TYPE B (20).....	51
9.4.1	TECHNICAL CHARACTERISTICS.....	52
9.4.2	WIRING CONNECTION	52
9.5	RCD SELF-RECLOSING (19 + 20)	52
9.5.1	TYPE A.....	52
9.5.2	TYPE B – PHASE I.....	54
9.5.3	TYPE B – PHASE II.....	57
9.6	SURGE PROTECTION (21,23).....	58
9.6.1	SURGE PROTECTION DEVICE	58
9.6.2	FUSE AS A SPAREPART	59
9.6.3	WIRING CONNECTION	59
9.6.4	CCL1-MINI WIRING.....	60
9.7	ANTI-VANDAL DOORS	61
9.7.1	WIRING CONNECTION	63
9.7.2	CCL1-MINI WIRING.....	63
9.8	ANTI-VANDAL KEY (31)	64

9.8.1	HARDWARE REPLACEMENT PROCEDURE	64
10	CHARGE POINT ADVANCED SETTINGS	67
10.1	CHARGE POINT MAXIMUM CURRENT OUTPUT	67
10.2	CHARGE POINT MAXIMUM CURRENT OUTPUT FOR EACH PLUG	69
10.3	AUTHORIZATION MODE	71
11	REPLACEMENT PARTS.....	72
12	ERRORS AND TROUBLESHOOTING	72
12.1	LCD MESSAGE ERRORS	72
12.1.1	ERRORS VARS CFG	73
12.1.2	ERROR DRIVER COM.....	74
12.1.3	ERROR TAMPER.....	75
12.1.4	ERROR RCD	75
12.1.5	ERROR MCB.....	75
12.2	OCPP 1.5 COMMON ERRORS	76
12.2.1	Connect failed in tcp_connect.....	76
12.2.2	Notifying Boot - 200.....	77
12.2.3	Notifying Boot - -1	77
12.2.4	HTTP/1.1 404 Not Found.....	77
12.2.5	Cannot get charge device name	78
12.2.6	SSL/TLS error	78
12.2.7	'Detail: bind failed in soap_bind /' 'Error 28'.....	78
12.2.8	Getting valid public ID timeout	79
12.2.9	No Data, get host by name failed in tcp_connect()	79
12.3	OCPP 1.6 COMMON ERRORS	80
12.3.1	CS Connection FAILED. Fail reason: Underlying Transport Error	80
12.3.2	CS Connection FAILED. Fail reason: Timer Expired	80
12.3.3	CS Connection FAILED. Fail reason: Invalid HTTP status	80
13	MAINTENANCE	81
13.1	VERIFICATION DOCUMENTS.....	82
14	TECHNICAL DATA	92
14.1	GENERAL.....	92
14.2	MODEL T	93
14.3	MODEL S.....	93
14.4	MODEL SS.....	94
14.5	MODEL TM	94
14.6	MODEL T-ONE	95
14.7	MODEL C63.....	95

14.8	MODEL C63-ONE.....	96
14.9	MODEL TM4	97
15	WIRING DIAGRAMS PHASE II.....	98
15.1	MODEL T	98
15.2	MODEL T RECLOSING V1	105
15.3	MODEL T RECLOSING V.2.....	112
15.4	MODEL S.....	119
15.5	MODEL SS.....	126
15.6	MODEL TM	131
15.7	MODEL TM4	137
15.7	MODEL C63-ONE	144
16	NEED HELP?	149

1 PREFACE



This manual provides service and maintenance information for Circontrol Charge Point, which has been designed and tested to allow electric vehicle charging, specified in IEC-61851.

This document has different sections describing electrical components inside the Charge Point and a step-by-step installation procedure.

It is mandatory to follow the basic security information supplied in this manual to ensure safe and proper installation.

Failure to follow safety instructions may involve personal injury, equipment damage and danger of death. CIRCONTROL is not responsible for events arising from such breach.

THE FOLLOWING SYMBOLS ARE USED FOR IMPORTANT SAFETY INSTRUCTIONS IN THIS DOCUMENT

	Before performing any maintenance, repair or manipulation of any equipment connections, disconnect the device from any power source.
	Pay attention to the instructions before performing any action to avoid any error, device failure or any detail that can be overlooked.
	Do not modify the unit. If modified, Circontrol will reject all responsibility and the warranty will be void.

All technical data contains all the necessary information to identify and make the replacement of the damaged part and make the commissioning for proper operation.

Certification

- Complies with IEC 61851, Electric vehicle conductive charging system (IEC 61851-1 and IEC 61851-22).
- Complies with IEC 62196, Plugs, socket-outlets, vehicle couplers and vehicle inlets (IEC 62196-1 and IEC 62196-2).
- Standards: 2014/35/UE, LVD;2014/30/UE, EMC.
- RFID complies with ISO 14443A/B.
- Modem 4G complies with CE/RED

2 RISKS PREVENTION

A safe work environment is not always enough to control all potential electrical hazards. You must be very cautious and work safely. Safety rules help you control your and others risk of injury or death from workplace hazards.

1. Avoid contact with energized electrical circuits.
2. Disconnect the power source before servicing or repairing electrical equipment.
3. Use only tools and equipment with non-conducting handles when working on electrical devices.
4. Never use metallic pencils or rulers, or wear rings or metal watchbands when working with electrical equipment.
5. When it is necessary to handle equipment that is plugged in, be sure hands are dry and, when possible, wear nonconductive gloves, protective clothes and shoes with insulated soles.
6. If it is safe to do so, work with only one hand, keeping the other hand at your side or in your pocket, away from all conductive material. This precaution reduces the likelihood of accidents that result in current passing through the chest cavity.
7. Enclose all electric contacts and conductors so that no one can accidentally come into contact.
8. Never handle electrical equipment when hands, feet, or body are wet or perspiring, or when standing on a wet floor.

3 IMPORTANT SAFETY INSTRUCTIONS

- Read all the instructions before using and installing this product.
- Do not use cables that are not in perfect conditions.
- Do not use this unit for anything other than electric vehicle charging modes contemplated in IEC 61851-1.
- Do not modify this unit. If modified, CIRCONTROL will reject all responsibility and the warranty will be void.
- Comply strictly with current safety regulations according to your country rules.
- Do not make repairs or manipulations with the unit energized.
- Only trained and qualified personnel should have access to low-voltage electrical parts inside the device.
- Check the installation annually by a qualified technician.
- Remove from service any item that has a fault that could be dangerous for users (broken plugs, caps that don't close...).
- Use only spare parts supplied by Circontrol.
- Do not use this product if the enclosure or the EV connector is broken, cracked, open, or shows any other indication of damage.

4 DEVICE OVERVIEW

4.1 FEATURES

- **Display:** Information about the status of the connectors and detailed data as energy (kWh) and charge duration.
- **Connector Lock:** Type 2 connector has a lock system to avoid disconnection of EV meanwhile is charging.
- **Light beacon:** Three colour LED indicates the status of the connectors.
- **RFID:** User identification.
- **Ethernet:** TCP/IP communication for remote supervision and configuration.
- **3G Modem (optional):** For those places where wired communications are not enough.
- **Energy metering:** Integrated meter that measures power and energy consumed by the EV during a charge transaction.
- **Remote access:** For supervision and control from everywhere.
- **Charge transaction history:** Charge Point can store information about the charge transactions.
- **OCPP:** Open standard communication protocol, allows communication between the Charge Point and the Central System.

4.2 PRODUCT EVOLUTION

Post eVolve Smart is a Smart Charge Point created in 2016 and it has been evolving to these days. For this reason, the Charge Point has different versions of its internal components' distribution called **phase I** and **phase II**.

The main purpose of these changes is to upgrade the components and optimize the inner space distribution.

Other minor changes such as software, firmware, communication between components, etc., provide more features to the Charge Points.

Some components are incompatible between the two phases. These incompatibilities are indicated for each device in this manual in their own section.

4.3 DIMENSIONS

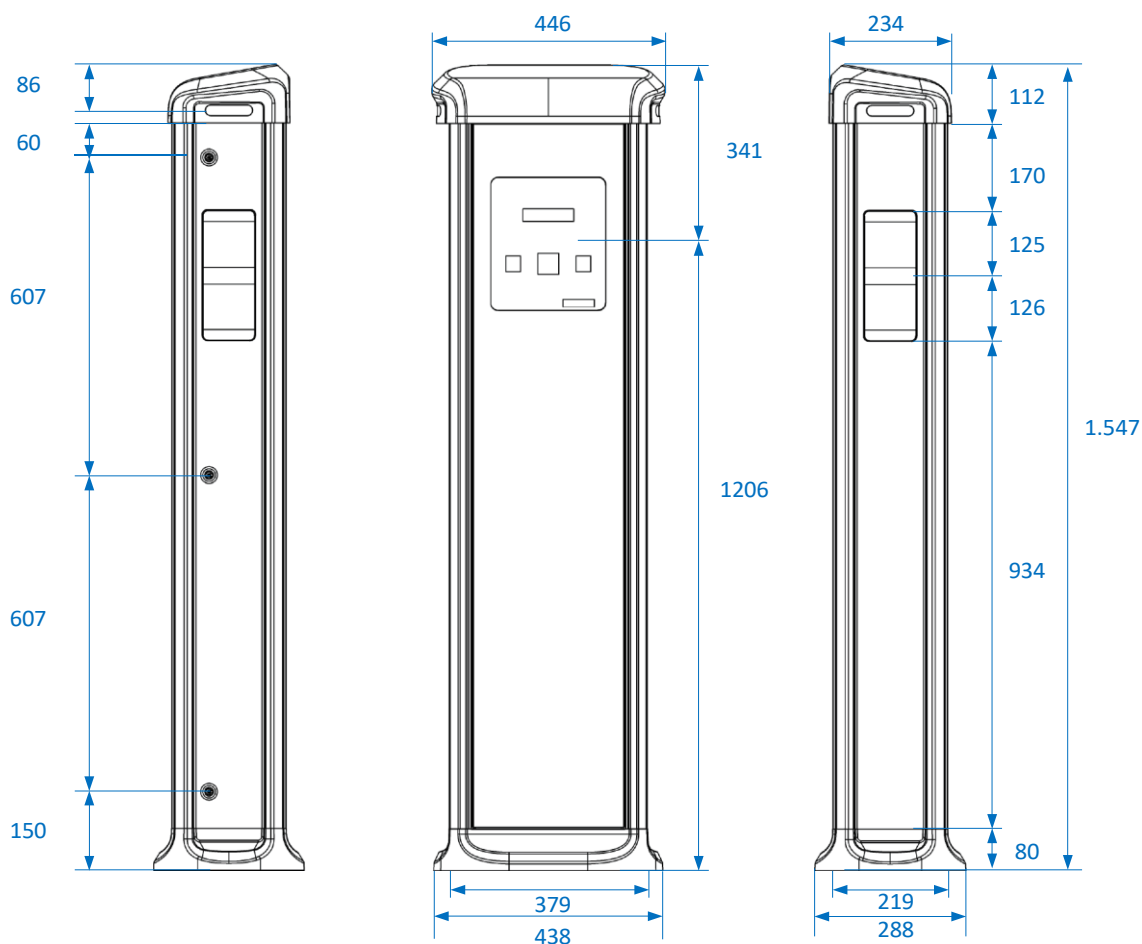

4.4 COMPONENTS OVERVIEW

4.4.1 PHASE I

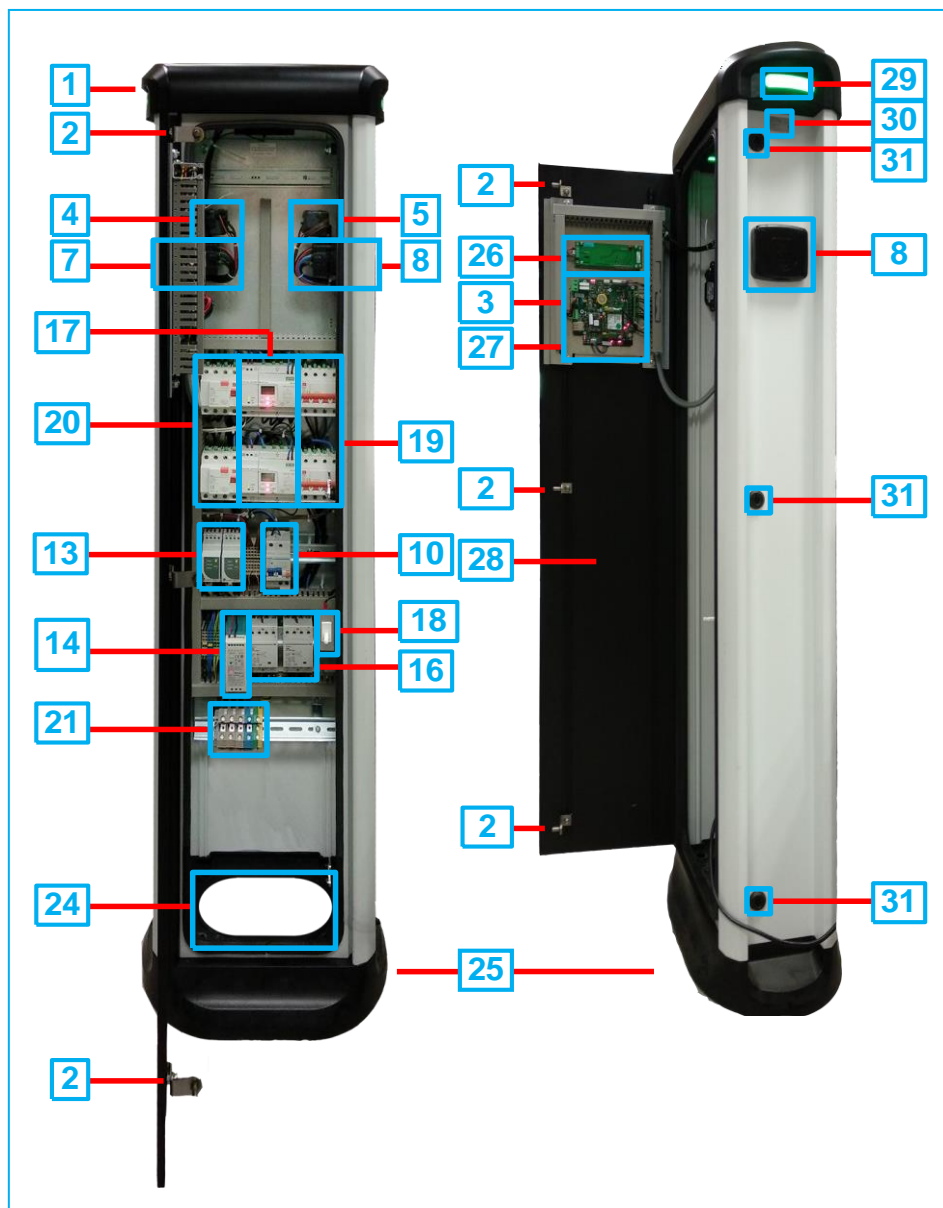

1 Hat	2 Door closure fasteners	3 CCL1-MINI
4 Locking system Plug A	5 Locking system Plug B	6 N/A
7 Socket type 2 Plug A	8 Socket type 2 Plug B	9 N/A
10 control MCB	11 N/A	12 N/A
13 Mode 3 DIN Rail	14 Control power supply	15 N/A
16 Current plug contactors	17 Energy meters	18 Tamper
19 MCB plug protections	20 RCD plug protections	21 Input terminals
22 N/A	23 N/A	24 Input power supply cables
25 Base	26 LCD	27 RFID reader
28 Door	29 RGB light state indicator	30 Identification product labels
31 Door closure		

4.4.2 PHASE II

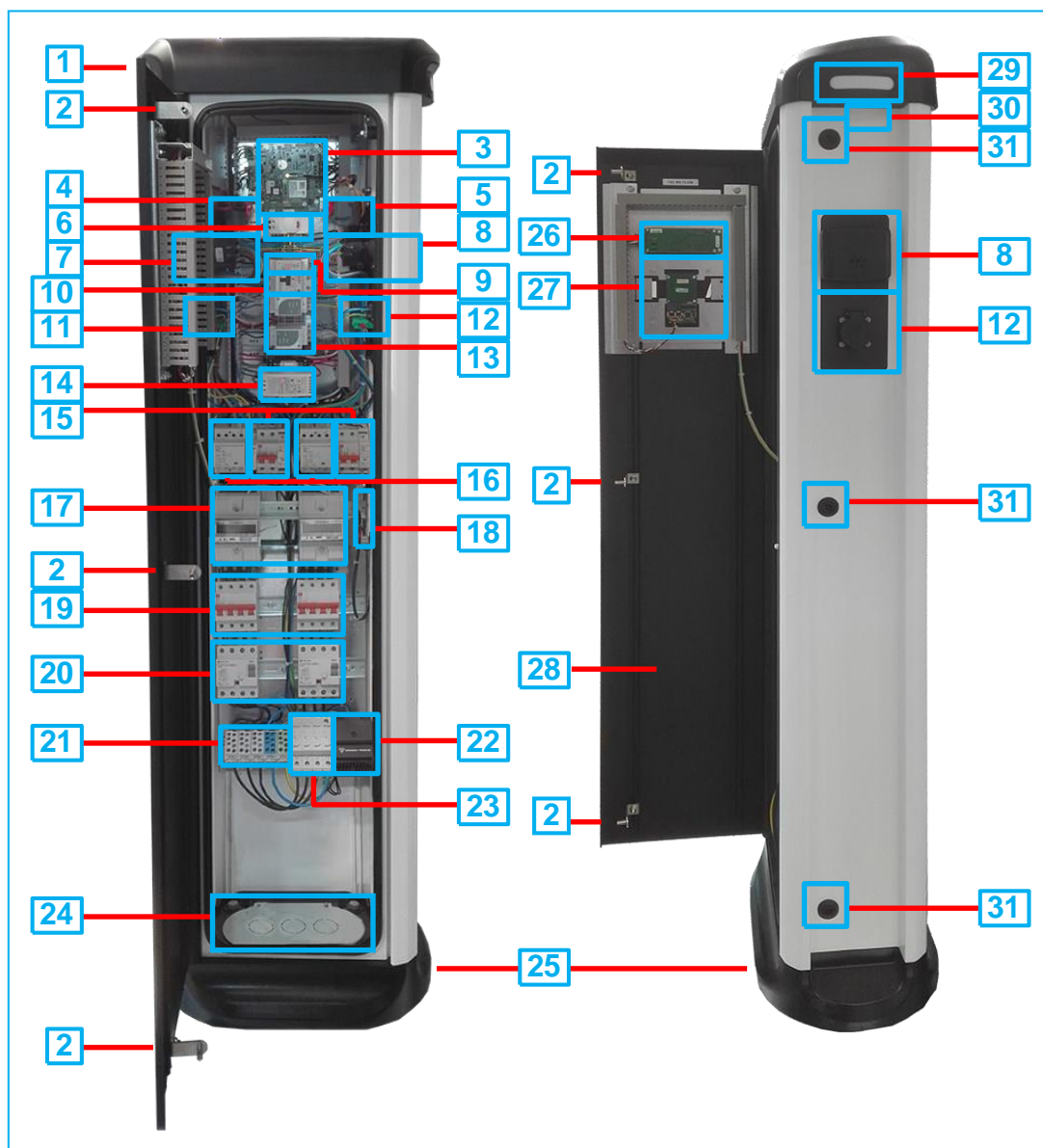

1 Hat	2 Door closure fasteners	3 CCL1-MINI
4 Locking system Plug A	5 Locking system Plug B	6 Thermostat LTK
7 Socket type 2 Plug A	8 Socket type 2 Plug B	9 Control power supply
10 Control MCB	11 Socket CEE 7/3 Plug A	12 Socket CEE 7/3 B
13 Mode 3 DIN rail	14 Control power supply	15 MCB CEE 7/3
16 Contactor CEE 7/3	17 Energy meters	18 Tamper
19 MCB plug protections	20 Contactor Socket	21 Input terminals
22 Heater	23 Surge protection	24 Input power supply cables
25 Base	26 LCD	27 RFID reader
28 Door	29 RGB light state indicator	30 Identification product labels
31 Door closure		

5 PERIPHERALS OVERVIEW

This section describes all the devices that have communication in the Charge Point and describes, step by step, how to setup any of its components if are replaced.

All devices are interconnected via RS-485 with the master: CCL1-MINI (3). In this configuration, the master device CCL1-MINI is centrally located along the set of RS-485 wires, there are some slave devices located at the end of the wires that would provide parameters and data to master device in real time.

Schematic below details the physical connections RS-485 for all the devices.

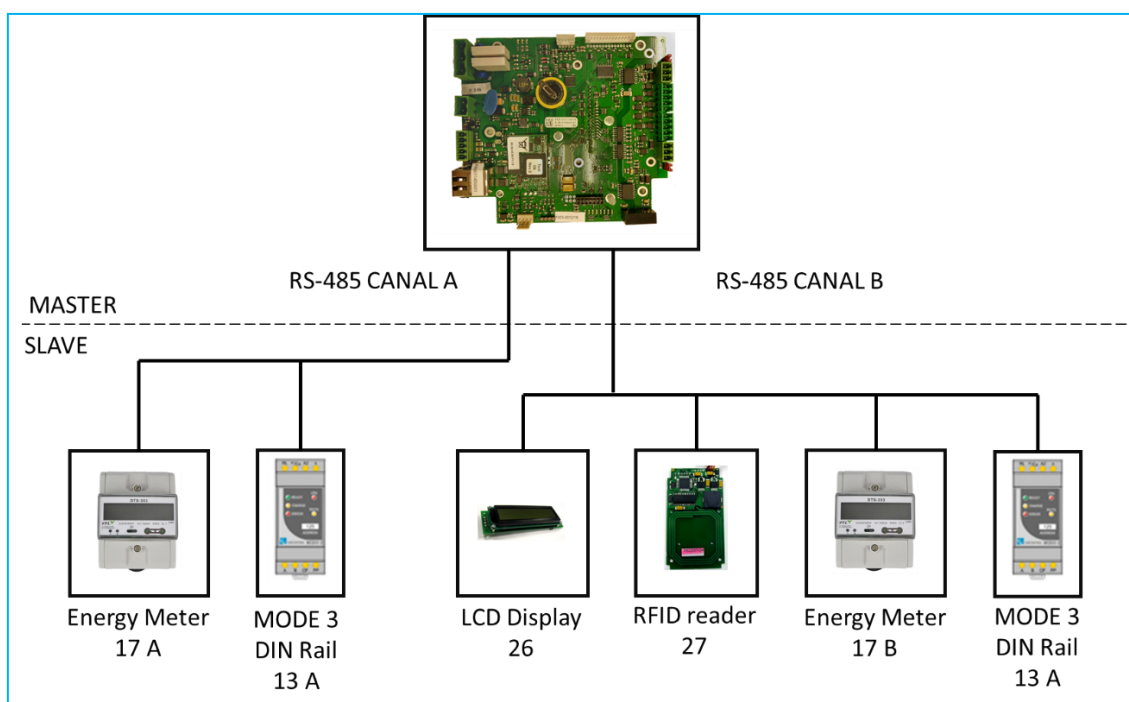

COMPONENTS	DESCRIPTION
26	LCD Display
27	RFID reader
17 A	Meter (Plug A)
17 B	Meter (Plug B)
13 A	Mode 3 Charge Controller (Plug A)
13 B	Mode 3 Charge Controller (Plug B)

5.1 PERIPHERALS CONFIGURATION TABLE

The table below shows all devices with its setup parameters to communicate slave devices with CCL1-MINI master controller with RS-485 protocol.

- Setup: Peripheral number.
- Setup: Baud rate

	RS-485 PORT A/1		RS-485 PORT B/2			
Device	Meter (Plug A)	Mode 3 Rail DIN (Plug A)	LCD display	RFID card reader	Mode 3 Rail DIN (Plug B)	Meter (Plug B)
	17 A	13 A	26	27	13 B	17 B
Peripheral number	7	8	9	1	96	8
Baud rate						
phase I	19200		19200			
phase II	9600		9600			

- It is important to respect the connection position of the devices shown in the electrical schemes.



- Do not modify the peripheral number of the devices other than the one specified in the table above.
- Do not modify the baud rate of the devices to one that is not specified in table above. It can cause loss of communication between devices.

6 CHARGE POINT MASTER DEVICES

6.1 CCL1-MINI INTEGRATED EMBEDDED DEVICE

CCL1-MINI device is the master controller device of the Charge Point and the most important element because it is specially designed to manage the Charge Point and all the scenarios of charge transaction.

There are two different models of CCL1-MINI device:

- CCL1-MINI
- CCL1-MINI with integrated 3G/4G modem.

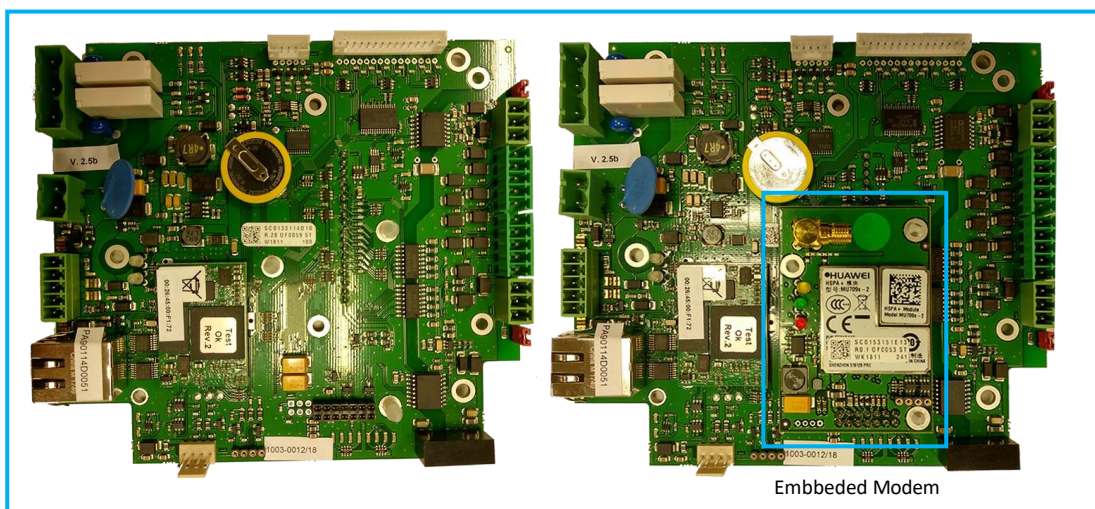

The communication protocol of CCL1-MINI is RS-485, used for communications with slave devices as RFID reader, energy meters or other devices using MODBUS RTU protocol.

The ethernet port integrated on the device is used for communication between computer and CCL1-MINI to extract the data stored.

6.1.1 CCL1-MINI - IN & OUTS

CCL1-MINI device has several ports of communication, digital outputs, relays, ethernet port, LHTTL port, debug port and GPRS antenna communication.

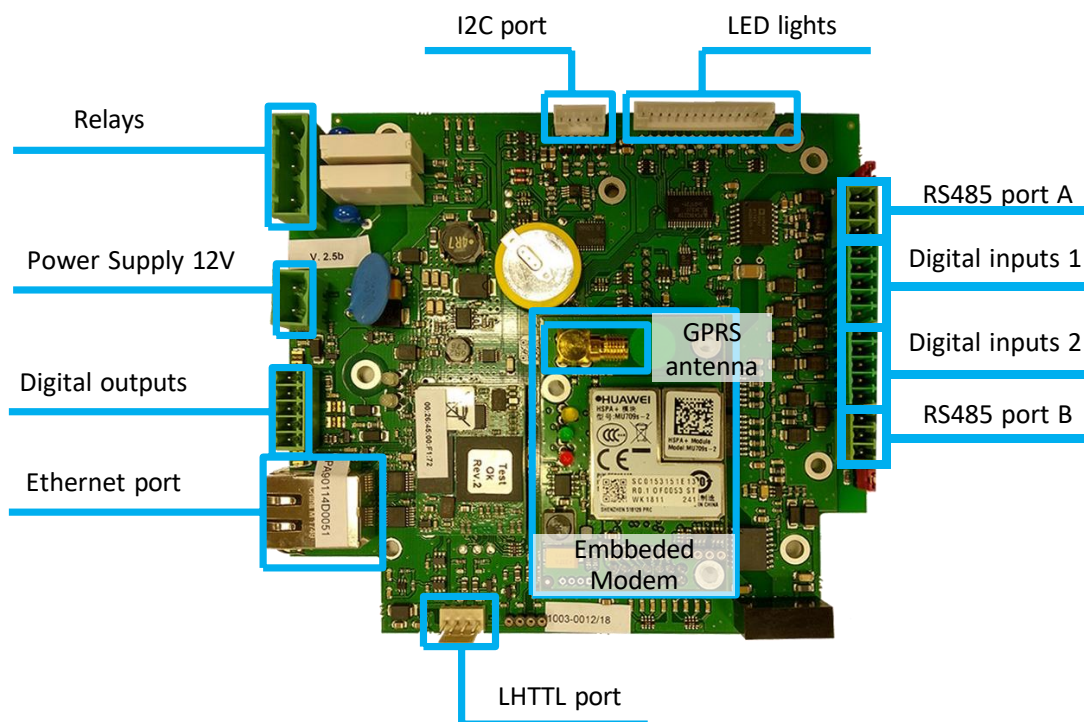

Digital outputs and inputs

The digital outputs are intended for different functions: control the LED beacon lights and the antivandal doors.

The digital inputs are intended for different functions:

- Digital inputs 1: Digital inputs to detect the status of the CEE 3/7 sockets.
- Digital inputs 2: Digital inputs to detect the status of the surge protection (tamper).

Relays

They are used to control the contactors that energize the CEE 7/3 sockets.

LHTTL port

CCL1-MINI has a LHTTL port to communicate with different devices such as the Legic RFID reader.

I2C port

Communication port intended to perform the debugging work.

LED beacon lights

It is a connector entirely dedicated to control the LED beacon lights.

RS-485 communications

As seen in the previous sections of this service manual, CCL1-MINI device has two RS-485 serial ports in order to communicate with slave devices. The following image allows identifying the two serial ports available on CCL1-MINI:

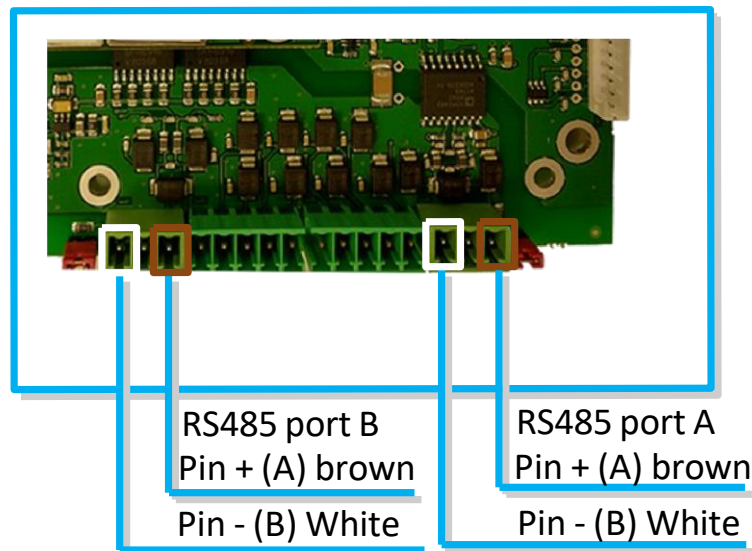

Ethernet port and embedded modem and GPRS antenna

They are dedicated to access the setup web page of the Charge Point and used as a method to link the Charge Point with the internet, allowing the access and the control, either manually or by a Central System (OCPP protocol).

6.1.2 TECHNICAL CHARACTERISTICS

POWER SUPPLY	
Input voltage	12V DC
Working temperature	-10...+60°C
SERIAL COMMUNICATIONS	
Type	2xRS-485, TTL
Baud rate supported	4800, 9600, 19200, 38400, 57600, 115200bps
CONNECTIVITY	
Ethernet	10/100 Base-T
Mobile	2G, 3G, 4G
TIME SETUP	
Clock	RTC. Synchronization with an internet time server

7 CHARGE POINT SLAVE DEVICES

This section describes in detail how to setup and quickly replace any device that can be found inside the Charge Point:

- MODE 3 (13)
- Energy meter (17)
- LCD DISPLAY (26)
- RFID READER (27)

7.1 MODE 3 CHARGE CONTROLLER (13)

Mode 3 DIN rail is the gateway of mode 3 communications and allows charging an electrical vehicle as defined in IEC 61851-1.



7.1.1 WIRING CONNECTION

	BUS RS-485 1: Terminal (+) 2: Terminal (-)	LED INDICATORS	
	VE connection 3: Proximity (PP) 4: Control Pilot (CP)	Ready	Electrical vehicle detected
	Contactor 5: Contactor coil	Charge	Power Contactor connected and electric vehicle charging
	Power Supply 6: L1 7: Neutral 8: Ground	Error	Proximity error or E status request
		CPU	Device powered ON
		RX/TX	RS-485 Communications activity

7.1.2 DEVICE CONFIGURATION PROCEDURE

No additional configuration is required to operate with Mode 3 DIN rail device.

7.1.3 TECHNICAL CHARACTERISTICS

POWER SUPPLY	
Voltage	85-290VAC / 120-410VDC
Frequency	47...63Hz
Working temperature	-10...+60°C
MECHANICAL CHARACTERISTICS	
Material	UL94-V0. Self-extinguishing
Protection	IP20
Dimensions	35 x 73 x 84.68mm
SERIAL	
Type	RS-485
Baud rate supported	4800, 9600, 19200, 34800, 57600bps
Default peripheral number	96
Default baud rate	9600bps

7.1.4 ADDITIONAL INFORMATION

Communication with the device is only possible via RS-485 communications through inputs 1 and 2.

The device integrates an Ethernet port, which does not allow connectivity to TCP/IP networks. It is used for internal use as digital inputs and outputs.

Default factory Modbus address is set at 96 and baud rate is set to 19200bps at phase I and 9600 at phase II.

There is a label on the right side of the device with the specifications as shown below.

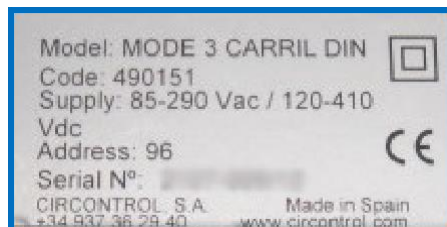

Please consider this information when it is replaced.

7.2 ENERGY METER (17)

7.2.1 SINGLE-PHASE CEM-C10 – PHASE I

The CEM-C10 device measures, calculates and displays the main electrical parameters on single-phase electrical wiring.

An external toroidal transformer is no needed to measure current parameters because it is integrated in the same device.

The CEM-M-RS-485 device is a communication gateway between the CEM-C10 and the local controller.



















CEM-C10



CEM-M-RS-485

7.2.1.1 DEVICE CONFIGURATION PROCEDURE

STEP	ACTION
1	<u>Press and hold button</u>  from CEM-C10 for at least 2 seconds.
2	Press  several times until reach "SETUP".
3	<u>Press and hold button</u>  from CEM-C10 for at least 2 seconds.
4	Press  two times to arrive to "ADDRESS".
5	<u>Press and hold button</u>  from CEM-C10 for at least 2 seconds to "0"00.
6	<u>Press and hold button</u>  from CEM-C10 for at least 2 seconds. The cursor moves from "0"00 to 0"0"0.
7	<u>Press and hold button</u>  from CEM-C10 for at least 2 seconds.

	The cursor moves from 0"0"0 to 00"0".
8	Press  several times to arrive to 00"8".
9	Press  two times to arrive to "DONE", wait for "ADRESS" to appear.
10	Press  one time to arrive to "BAUD".
11	<u>Press and hold button</u>  from CEM-C10 for at least 2 seconds to "9600".
12	Press  one time to arrive to "19200".
13	Press  two times to arrive to "DONE", wait for "BAUD" to appear.
14	Press  five times to arrive to "RETURN".
15	<u>Press and hold button</u>  from CEM-C10 for at least 2 seconds to "SETUP".
16	Press  two times to arrive to "RETURN".
17	<u>Press and hold button</u>  from CEM-C10 more than 2 seconds.

7.2.1.2 TECHNICAL CHARACTERISTICS

POWER SUPPLY	
Voltage	230/127 VAC ±20%
Frequency	50...60Hz
Working temperature	-25...+70°C
Relative humidity	5..95%
Maximum consumption	10 VA
SERIAL	
Type	RS-485
Baud rate supported	9600, 19200, 38400
LOAD MEASUREMENT	
Load Active energy measure accuracy	Class B (EN 50470) Class 1 (IEC 62053-21)
Load reactive energy measure accuracy	Class 2.0 (IEC 62053-23)
Voltage	3 x 127/220 Vc.a.
Frequency	50...60Hz

7.2.1.3 WIRING CONNECTION

Following image shows a detailed schematic of the connections in the CCL1-MINI PCB and in each Plug. Please, refer to “7.2.1.4” section for more details.

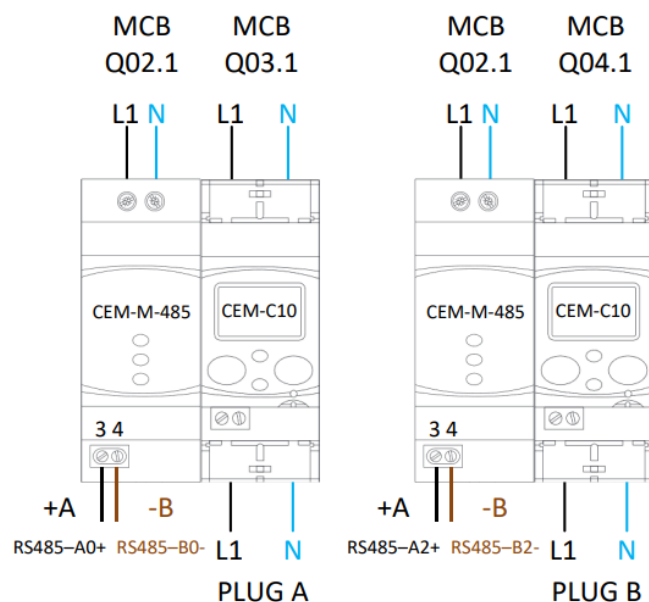

7.2.1.4 CCL1-MINI WIRING CONNECTION

Following image shows a detailed schematic of the connections in the CCL1-MINI PCB. Please, refer to “TECHNICAL DATA” section for more details.

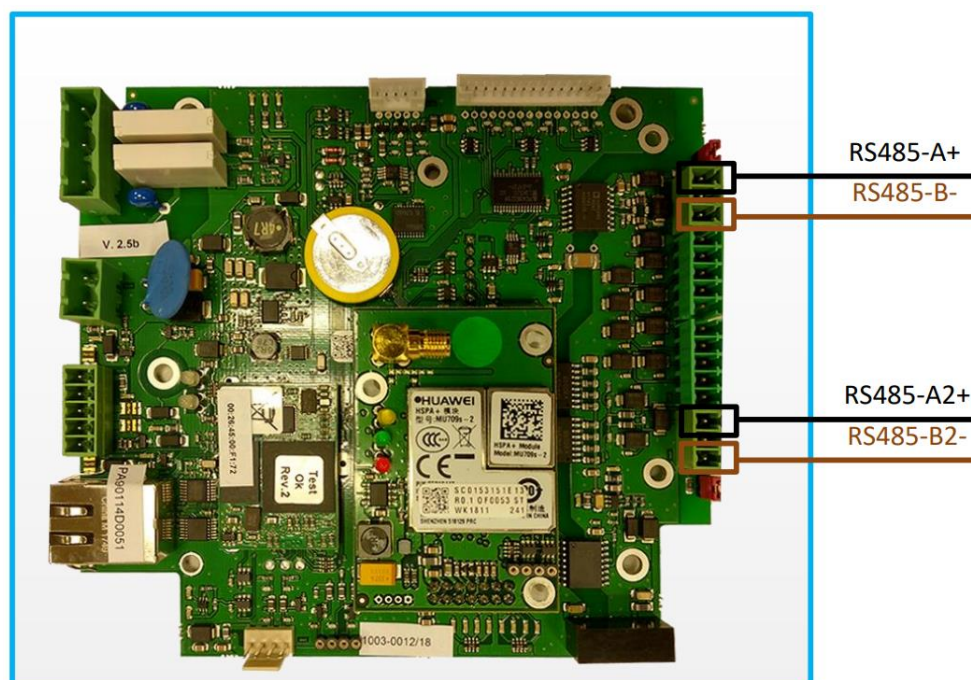

7.2.2 THREE-PHASE CEM-C20 METER – PHASE I









The CEM-C20 device measures, calculates and displays the main electrical parameters on three-phase electrical wiring.









An external toroidal transformer is no needed to measure current parameters because it is integrated into the same device.

The CEM-M-RS-485 device is a communication gateway between the CEM-C20 and the local controller.



7.2.2.1 DEVICE CONFIGURATION PROCEDURE

STEP	ACTION
1	<u>Press and hold button</u>  from CEM-C20 for at least 2 seconds.
2	Press  several times until reach "SETUP".
3	<u>Press and hold button</u>  from CEM-C20 for at least 2 sec
4	Press  two times to arrive to "ADDRESS".
5	<u>Press and hold button</u>  from CEM-C20 for at least 2 seconds to "0"00
6	<u>Press and hold button</u>  from CEM-C20 for at least 2 seconds. The cursor moves from "0"00 to 0"0"0.
7	<u>Press and hold button</u>  from CEM-C20 for at least 2 seconds. The cursor moves from 0"0"0 to 00"0".
8	Press  several times until reach 00"8".

9	Press  two times to arrive to “DONE”, wait for “ADRESS” to appear.
10	Press  one time to arrive to “BAUD”.
11	<u>Press and hold button</u>  from CEM-C20 for at least 2 seconds to “9600”.
12	Press  one time to arrive to “19200”.
13	Press  two times to arrive to “DONE”, wait for “BAUD” to appear.
14	Press  five times to arrive to “RETURN”.
15	<u>Press and hold button</u>  from CEM-C20 for at least 2 seconds to “SETUP”.
16	Press  two times to arrive to “RETURN”.
17	<u>Press and hold button</u>  from CEM-C20 for at least 2 seconds.

7.2.2.2 TECHNICAL CHARACTERISTICS

POWER SUPPLY	
Voltage	230/127 VAC ±20%
Frequency	50...60Hz
Working temperature	-25...+70°C
Relative humidity	5..95%
Maximum consumption	10 VA
SERIAL	
Type	RS-485
Baud rate supported	9600, 19200, 38400
LOAD MEASUREMENT	
Load Active energy measure accuracy	Class B (EN 50470) Class 1 (IEC 62053-21)
Load reactive energy measure accuracy	Class 2.0 (IEC 62053-23)
Voltage	3 x 127/220...3 x 230/400 Vc.a.
Frequency	50...60Hz

7.2.2.3 WIRING CONNECTION

Following image shows a detailed schematic of the connections in the CCL1-MINI PCB and in each Plug. Please, refer to “7.2.1.4” section for more details.

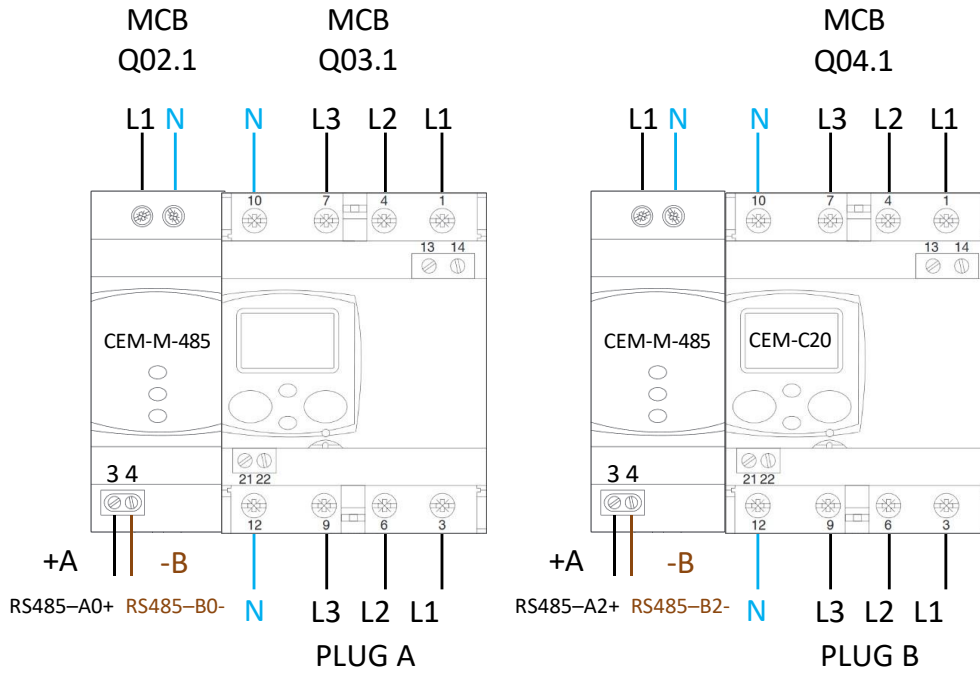

7.2.2.4 CCL1-MINI WIRING CONNECTION

Following image shows a detailed schematic of the connections in the CCL1-MINI PCB. Please, refer to “ TECHNICAL DATA” section for more details.

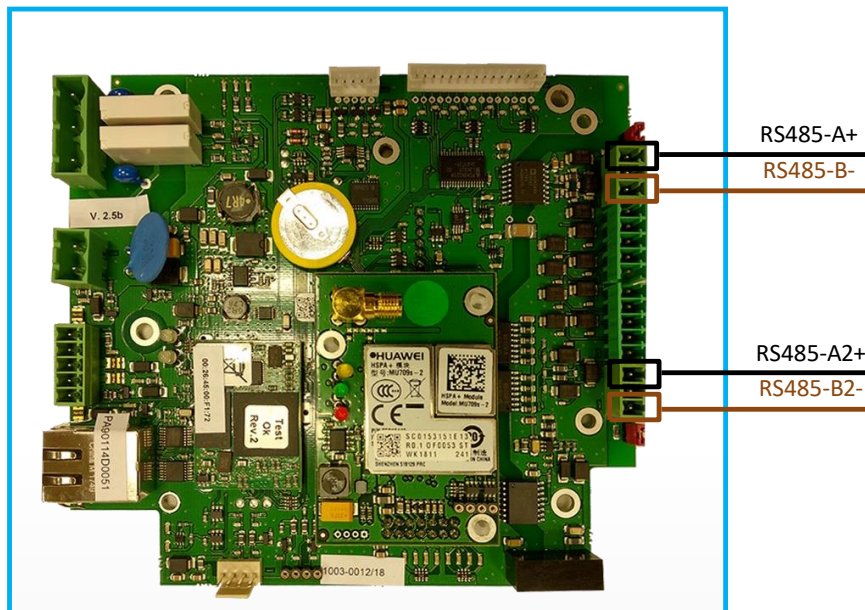

7.2.3 SINGLE-PHASE YTL METER – PHASE II

YTL meter is a single phase, two wire with RS-485 DIN rail electronic meter. This meter complies with EN50470-1/3 standards. It can measure the active and reactive energy consumption.



7.2.3.1 WIRING CONNECTION

Following image shows a detailed schematic of the connections in the CCL1-MINI PCB and in each Plug. Please, refer to “7.2.3.2” section for more details.

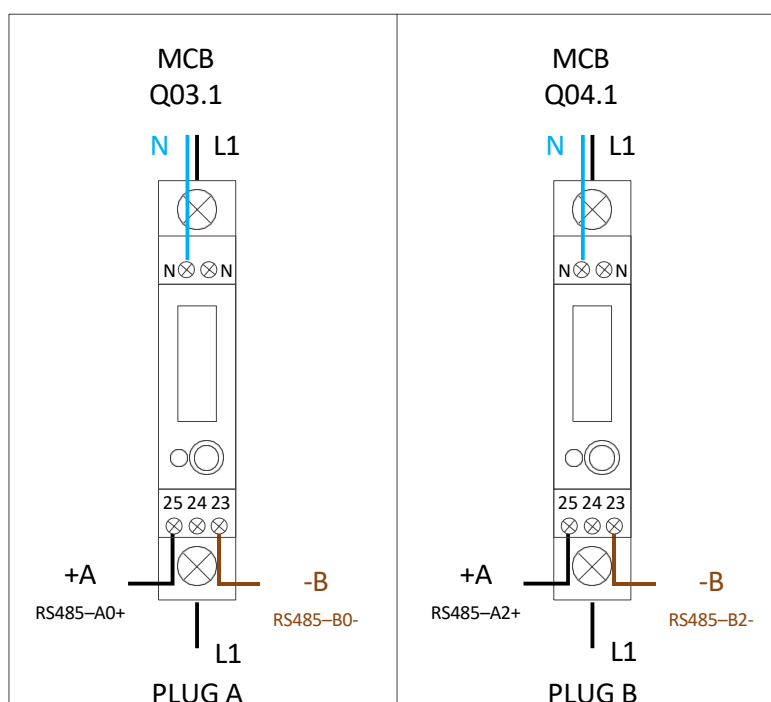

7.2.3.2 CCL1-MINI WIRING CONNECTION

Following image shows a detailed schematic of the connections in the CCL1-MINI PCB. Please, refer to “ TECHNICAL DATA” section for more details.

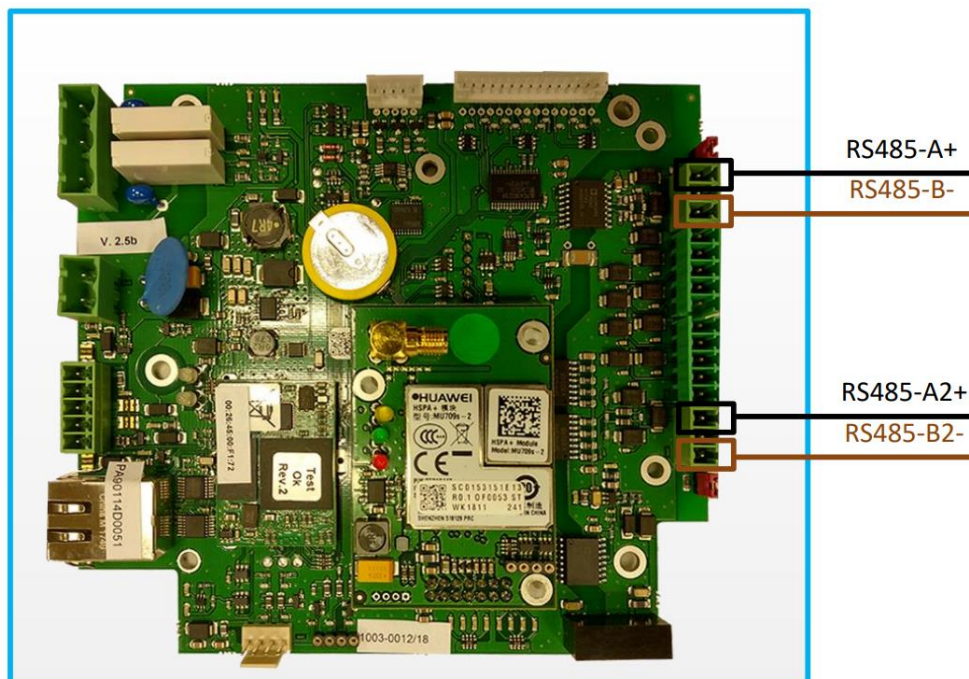

7.2.4 THREE-PHASE YTL METER – PHASE II

YTL meter is a three phase, four wire with RS-485, DIN rail, electronic meter. This meter complies with EN50470-1/3 standards. It can measure the active and reactive energy consumption.



7.2.4.1 LCD DISPLAY

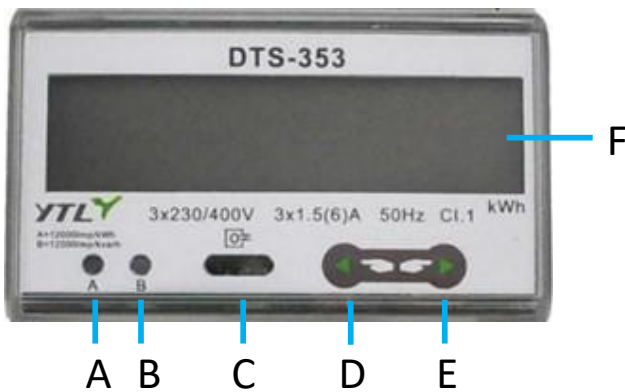

A	Active pulse LED
B	Reactive pulse LED
C	Near infrared communication
D	Reverse page button
E	Forward page button
F	LCD Display

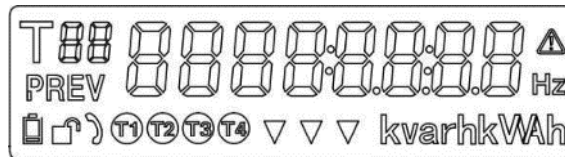

	Present tariff indicator
	Content indicate, it can be shown T1/ T2/ T3/ T4, L1/ L2/ L3
	Frequency display
	kWh unit display, it can be shown kW, kWh, Kvarh, V, A and kVA

7.2.4.2 ENERGY METER CONTENT

Page	Content	Unit	LCD sign	Format
1	DATE			XX-XX-XX
2	TIME			XX:XX:XX
3	Total Active Energy	kWh		6+2 000000.00
4	T1 Active Energy	kWh	T01	6+2 000000.00
5	T2 Active Energy	kWh	T02	6+2 000000.00
6	T3 Active Energy	kWh	T03	6+2 000000.00
7	T4 Active Energy	kWh	T04	6+2 000000.00
8	Total Reactive Energy	kVarh		6+2 000000.00
9	T1 Total Reactive Energy	kVarh	T11	6+2 000000.00
10	T2 Total Reactive Energy	kVarh	T12	6+2 000000.00
11	T3 Total Reactive Energy	kVarh	T13	6+2 000000.00
12	T4 Total Reactive Energy	kVarh	T14	6+2 000000.00
13	L1 voltage	V	L1	3+1 000.0
14	L2 voltage	V	L2	3+1 000.0
15	L3 voltage	V	L3	3+1 000.0
16	L1 current	A	L1	4+2 0000.00
17	L2 current	A	L2	4+2 0000.00

18	L3 current	A	L3	4+2 0000.00
19	Total active power	kW		5+3 00000.000
20	L1 active power	kW	L1	5+3 00000.000
21	L2 active power	kW	L2	5+3 00000.000
22	L3 active power	kW	L3	5+3 00000.000
23	Total Apparent Power	kVA		5+3 00000.000
24	L1 Apparent Power	kVA	L1	5+3 00000.000
25	L2 Apparent Power	kVA	L2	5+3 00000.000
26	L3 Apparent Power	kVA	L3	5+3 00000.000
27	Total COS			1+2 0.00
28	L1COS		L1	1+2 0.00
29	L2COS		L2	1+2 0.00
30	L3COS		L3	1+2 0.00
31	Frequency	Hz		2+2 00.00
32	T1 Demand	kW	T-1	6+2 000000.00
33	T2 Demand	kW	T-2	6+2 000000.00
34	T3 Demand	kW	T-3	6+2 000000.00
35	T4 Demand	kW	T-4	6+2 000000.00
36	Resettable Active Energy	kWh	Start measurement after function open, which can be reset.	000000.00
37	Combinatorial active status word			S 11 111
38	Cycle time		1-30s	Lcd-t 05
39	Impulse Output			S0 1000
40	Measuring Mode			COdE 01
41	IR address/meter serial number		IR address	12345678
42	MODBUS ID		Address is 0x10 shows 016	Id 255
43	MODBUS Baudrate		485 Baudrate	bd 9600
44	Software Version			V 1.01

7.2.4.3 TECHNICAL CHARACTERISTICS

Features	
Voltage, frequency	230/400V AC, 50 Hz
Accuracy class	B
Working temperature	-20...+60°C
Type serial communication	RS-485
Display	LCD 6+2
Standard	EN50470-1/3

7.2.4.4 WIRING CONNECTION

Following image shows a detailed schematic of the connections in the CCL1-MINI PCB and in each Plug.

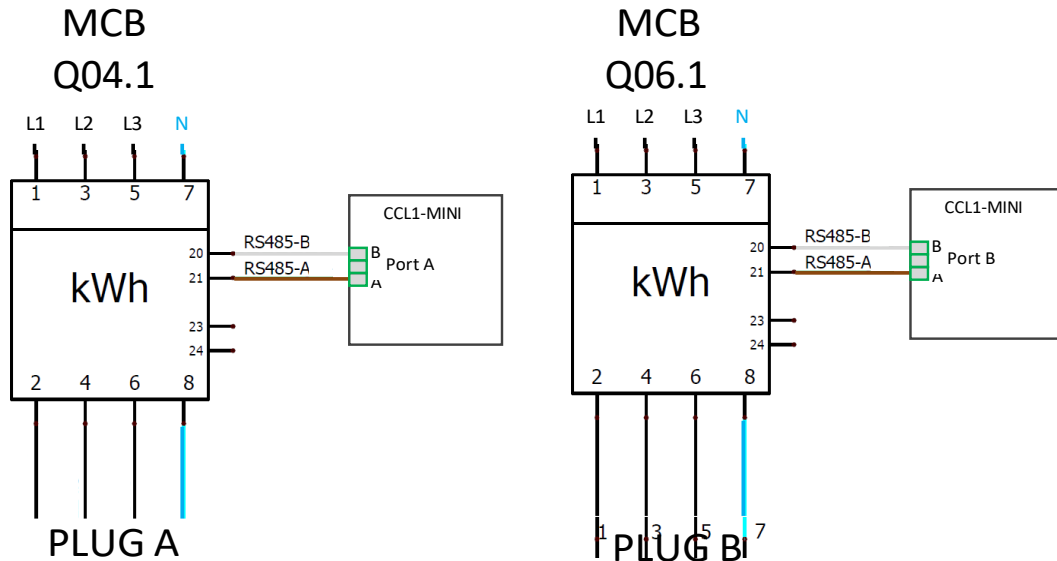

7.3 LCD DISPLAY (26)

The LCD Display informs the end-user about how to charge the EV and about the errors to maintenance staff in case of fault. Information is displayed in real time and it shows the power consumption, the charge duration and other information and instructions.



7.3.1 TECHNICAL CHARACTERISTICS

POWER SUPPLY	
Voltage	12V DC
Working temperature	-10...+60°C
SERIAL	
Type	RS-485
Baud rate supported	4800, 9600, 19200 bps
Default peripheral number	63
Default baud rate	9600bps

7.3.2 WIRING CONNECTION

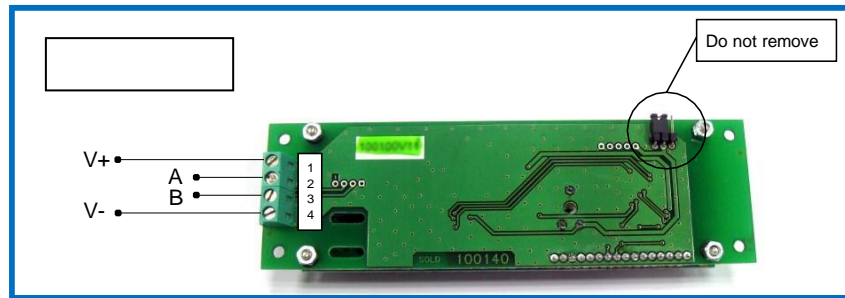

POWER SUPPLY			RS-485 COMMUNICATIONS		
TERMINAL	SIGNAL	WIRE COLOUR	TERMINAL	SIGNAL	WIRE COLOUR
1	V+ (12V)	Red	2	A (+)	Brown
4	V- (GND)	Black	3	B (-)	White

7.3.3 DEVICE CONFIGURATION PROCEDURE

- No additional configuration is required to operate with LCD display.

7.3.4 ADDITIONAL INFORMATION

INFORMATION ON POWER UP

Display shows the following message when device is powered up:



Note. Peripheral number is shown as hexadecimal number

DISPLAY CONTRAST

LCD display allows changing the screen contrasts manually with a screwdriver.

Look for a potentiometer at the back of the display, as shown in the following image:

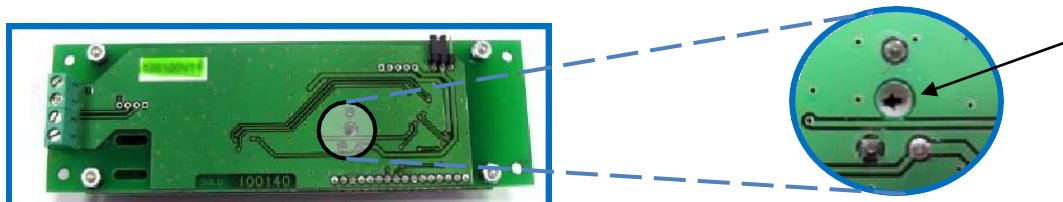

	<ul style="list-style-type: none"> - Position of the potentiometer can be different in each display. - Do not modify it if the screen contrast is correct.
--	--

7.4 RFID READER (27)

The RFID reader is a device that can send and receive radio signals with RFID tags to identify the end-user without physical contact between the Charge Point and the card.

There are two RF reader options

- MIFARE: The default reader with a several ISO certificated.
- LEGIC: Optional reader with a long range of ISO certifications.

7.4.1 MIFARE RFID READER

7.4.1.1 DEVICE CONFIGURATION PROCEDURE

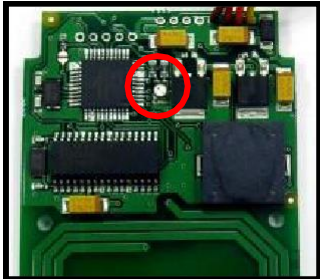
STEP	ACTION
1	<p>RFID reader has a LED status indicator. Look at the LED status indicator colour:</p>  <ul style="list-style-type: none"> • Green LED: RFID configured and ready for use. In this case, there is no additional configuration required to operate with RFID reader. • Orange LED: RFID not configured. Follow next steps to configure it.
2	<p>⚠ Remember that the RFID reader shall be connected to port B on CCL1-MINI master device.</p>
3	<p>Turn off the circuit breaker (Q3, refers to “15-Wiring diagrams” section) and wait for a while.</p>
4	<p>Turn on the circuit breaker (Q03.1, refers to “15-Wiring diagrams” section) and show the RFID card to the RFID reader. RFID reader LED status indicator changes from orange to red.</p>
5	<p>Wait 5 minutes until the Charge Point ends their starting and the LED beacon from plug A and plug B turned ON.</p>
6	<p>Look at the LED status indicator colour of the RFID card reader:</p> <ul style="list-style-type: none"> • Green LED: RFID configured and ready for use. In this case, process is completed. • Red LED: RFID not configured. Start again from the step number 3.

7.4.1.2 TECHNICAL CHARACTERISTICS

POWER SUPPLY	
Voltage	12V DC
Working temperature	-10...+60°C
SERIAL	
Type	RS-485
Baud rate supported	4800, 9600, 19200 bps
Default peripheral number	1
Default baud rate	9600 bps
Standards	ISO 14443 A & B

7.4.1.3 WIRING CONNECTION

Following image shows a detailed schematic of the connections in the CCL1-MINI PCB and to the 12 V Power Supply device (8).

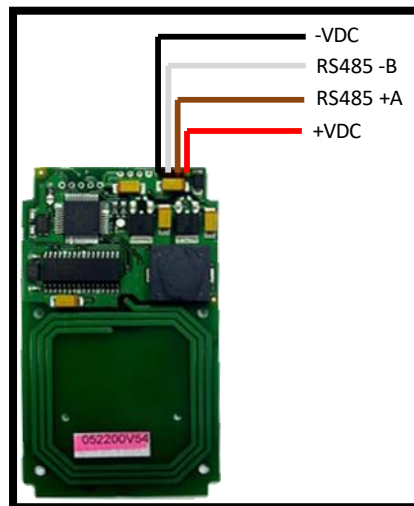

Following image shows a detailed schematic of the connections in the CCL1-MINI PCB. Please, refer to “ TECHNICAL DATA” section for more details.

POWER SUPPLY		RS-485 COMMUNICATIONS	
WIRE COLOUR	SIGNAL	WIRE COLOUR	SIGNAL
Red	V+ (12V)	Brown	A (+)
Black	V- (GND)	White	B (-)

7.4.2 LEGIC RFID READER (OPTIONAL)



7.4.2.1 TECHNICAL CHARACTERISTICS

POWER SUPPLY	
Voltage	5V ±10%
Working temperature	-25°C up to +80°C
SERIAL	
Type	RS-232
Baud rate supported	1200, 2400, 4800, 9600, 19200, 38400, 57600bps
Default peripheral number	1
Default baud rate	9600bps
Standards	<ul style="list-style-type: none"> • LEGIC Advant • LEGIC Prime • ISO14443 A+B compatible to part 4: MIFARE DESFireEV13), MIFARE Plus S, X3), MIFARE Pro X3), MIFARE SmartMX3), SLE66Rxx (my-d move)3), SLE44R351), PayPass1), NTAG2xx4), • ISO15693:EM4x353), Tag-It3), SRF55Vxx (my-d vicinity)3), ICODE SLI3) • MIFARE: Classic3), Classic EV14), Mini1), Ultralight3), Ultralight C3), UltralightEV14) • Sony FeliCa1) • NFC Forum Tag Type 2-43) • PicoPass1), HID iCLASS1), HID iCLASS SE/SR1)

7.4.2.2 WIRING CONNECTION

Picture below shows how to connect the RFID LEGIC reader to the CCL1-MINI. Please, refer to “7.4.2.3” section for more details.

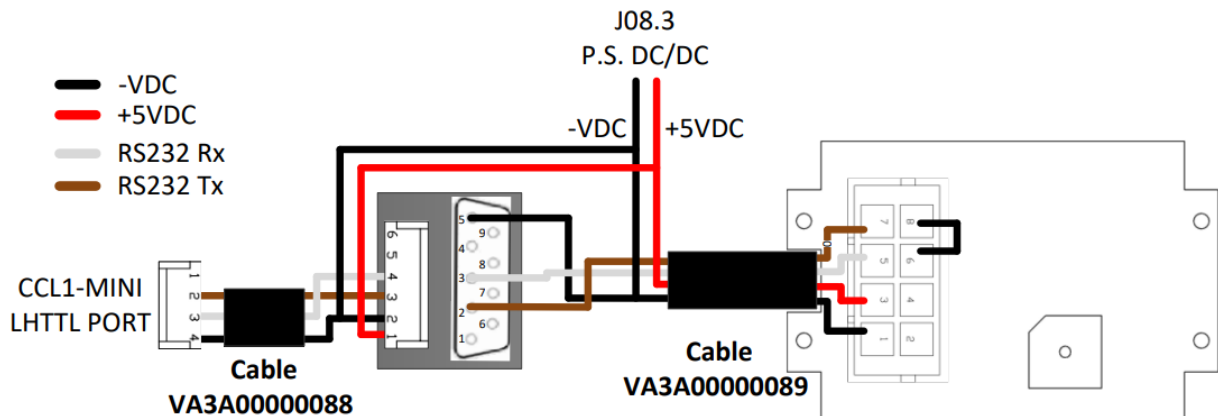

Picture below shows how to connect the RFID LEGIC reader to the power supply.

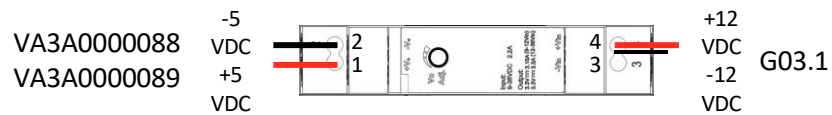

7.4.2.3 CCL1-MINI WIRING

Following image shows a detailed schematic of the connections in the CCL1-MINI PCB. Please, refer to “ TECHNICAL DATA” section for more details.

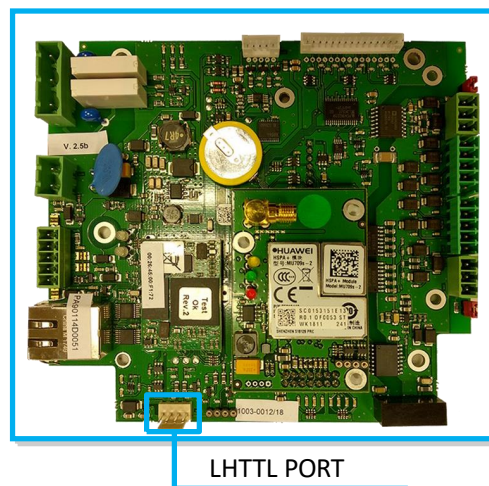

8 OTHER DEVICES

This section describes in detail how to setup and replace easily any device that can be found inside the Charge Point:

- Modem (3)
- Low temperature kit (6 + 22)
- Power supply (9)
- Tamper switch (18)
- Interface RGB beacon LED converter board (29)

8.1 MODEM (3)

8.1.1 MODEM MODEL IDENTIFICATION

There are different types of modems depending **the model of the Charge Point** and the **location** where it is going to be installed.

- Identify your Modem 3G:

Modems and Locations
HUAWEI MU709s-2 (Europe and China)
HUAWEI MU709s-6 (Asia Pacific and Latin America)

- Identify your Modem 4G:

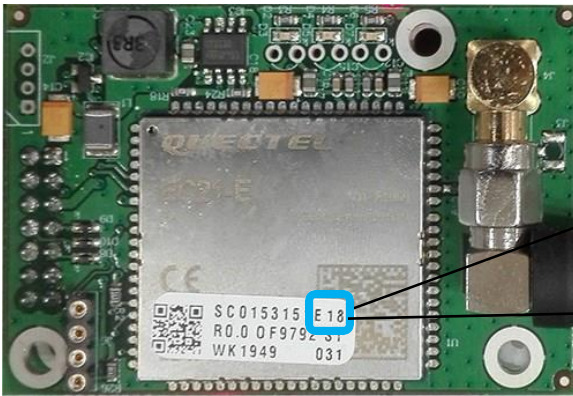

Modems and Locations
QUECTEL EC21-E SC015315 <u>E18</u> (Europe and China)
QUECTEL EC21-E SC015315 <u>E19</u> (Asia Pacific and Latin America)

8.1.2 HARDWARE REPLACEMENT PROCEDURE (only for 4G series)

STEP	ACTION
1	<p>Firstly, switch OFF the individual derivation MCB. After ensuring that the unit is not energized, open the unit from the front side and identify the CCL1-MINI device.</p>
2	<p>Disconnect the Antenna from the unit</p>

3

Remove the following screw as shown in the following image:

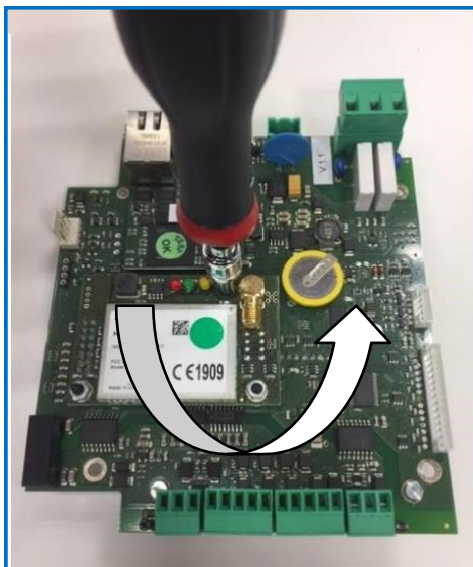

4

Remove the modem board from the CCL1-MINI device as it is shown in the image:

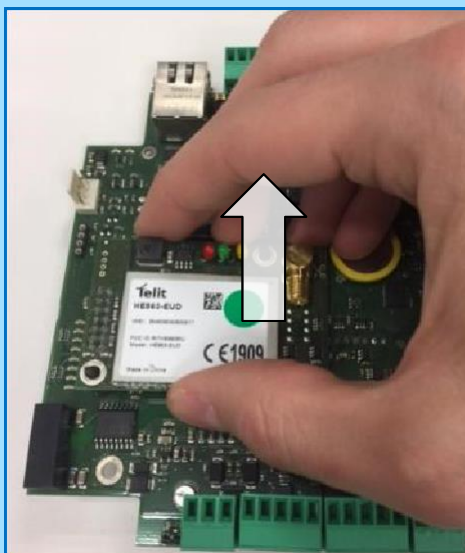

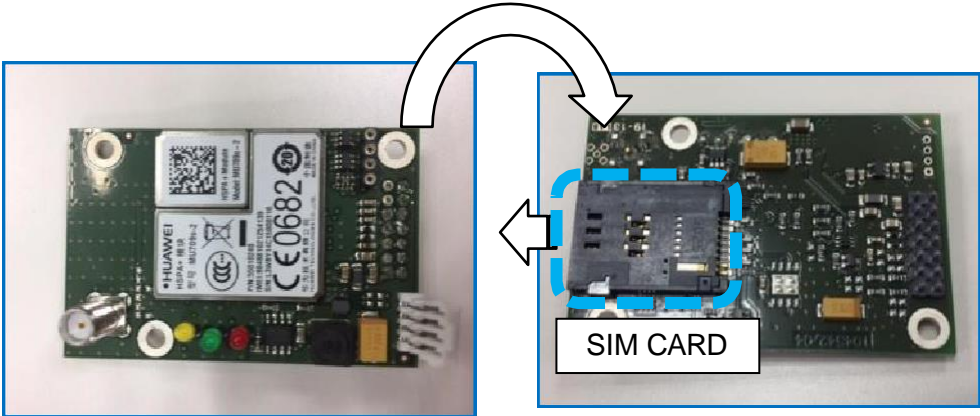
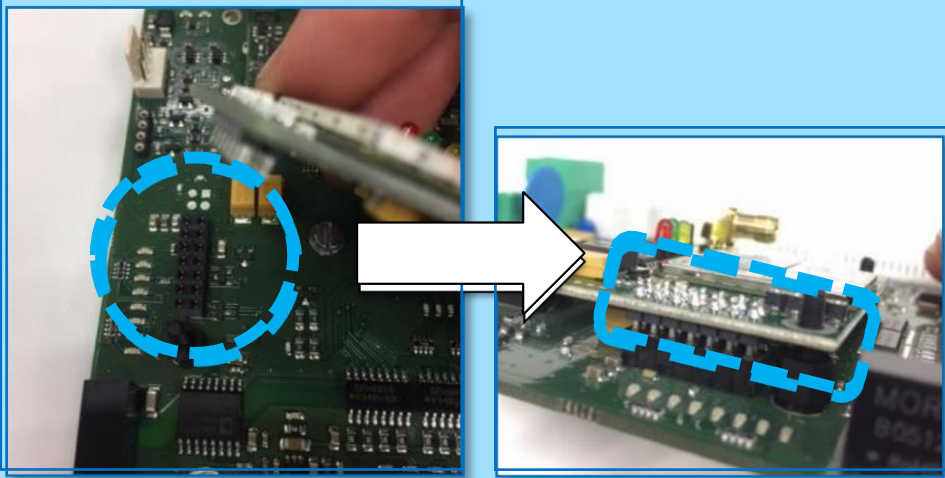
<p>5</p>	<p>SIM card holder is in the other side of the Modem. Press and remove the SIM card carefully.</p> 
<p>6</p>	<p>Install the new Modem being careful with the CCL1 MINI connector, all the pins shall fit correctly.</p> 
<p>7</p>	<p>Follow the same process of disassembly inversely to install the new modem.</p>

8.2 LOW TEMPERATURE KIT (6 + 22)

The heater has two main elements:

1. **Bimetal thermostats (6):** It controls the temperature inside the Charge Point enclosure to avoid the low temperature.
2. **Heater (22):** It is a self-regulating PTC element, that ensures a constant temperature operation by preventing the formation of condensation.



8.2.1 TECHNICAL CHARACTERISTICS

8.2.1.1 THERMOSTAT

Rated voltage	Rated current	Contact current	Setting range	Net weight
110-250 Vac	10A	15A	0-60 °C	50g

8.2.1.2 HEATER

Heating power*	Absorbed current*	Operating current	Inrush current	Weight
150W	10 A	-45 to 70°C	12 A	300 g

*The values above about *heating power, current and temperature* and obtained at 230Vac, 50Hz and ambient temperature conditions of 20±°C after working for 10 minutes.

8.2.2 WIRING CONNECTION

Following image shows a detailed schematic of the connections. Please, refer to "TECHNICAL DATA" section for more details.

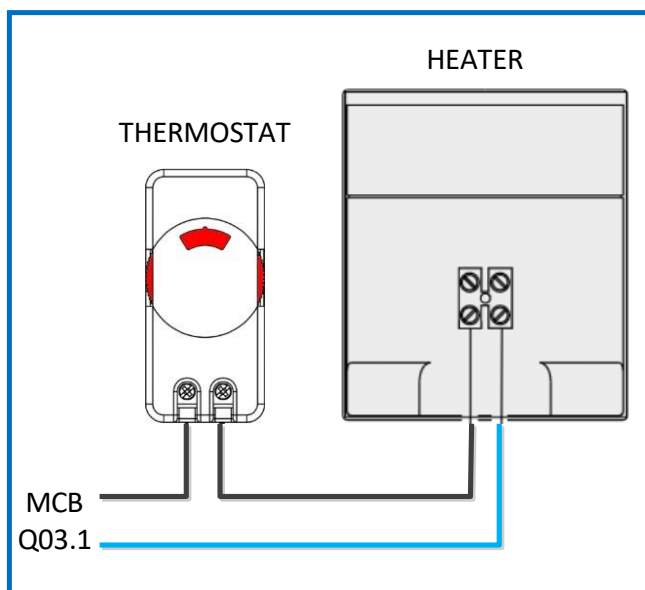

8.2.3 DEVICE CONFIGURATION PROCEDURE

- **Thermostat is installed at the top of the Charge Point.** Please, refer to "COMPONENTS OVERVIEW" section for more details.
- **Heater is installed at the bottom of the Charge Point** in order to supply heat to all devices located in the upper part. Please, refer to "COMPONENTS OVERVIEW" section for more details.



The recommended setting of the thermostat is at 5°C. If thermostat value is changed, the normal operation of the devices can be affected.



8.3 POWER SUPPLY (9)

8.3.1 MAIN POWER SUPPLY

The main power supply is a device that converts the 230Vac voltage to 12Vdc to supply power to different devices inside Charge Point (RFID reader, CCL1-MINI device, etc.).



- | | |
|---|--|
|  | <ul style="list-style-type: none"> - Check output voltage at every Charge Point maintenance of, in order to ensure that all devices will work properly. - CCL1-MINI device will not work properly if the output of power supply is not at least 12V. |
|---|--|

8.3.1.1 TECHNICAL CHARACTERISTICS

A table of technical specifications of the power supply is shown below:

OUTPUT		INPUT	
DC Voltage	12 V	Voltage range	85...264 VAC
Rated current	1.25 A	Frequency range	47...63 Hz
Current range	0...1.25 A	WATHER CONDITIONS	
Rated power	15 W	Working temperature	-30...+70 °C
Voltage adj. range	10.8-13.2 V	Working humidity	20...90%

8.3.1.2 WIRING CONNECTION

Following image shows a detailed scheme of the power supply connections. Please, refer to “ TECHNICAL DATA” section for more details.

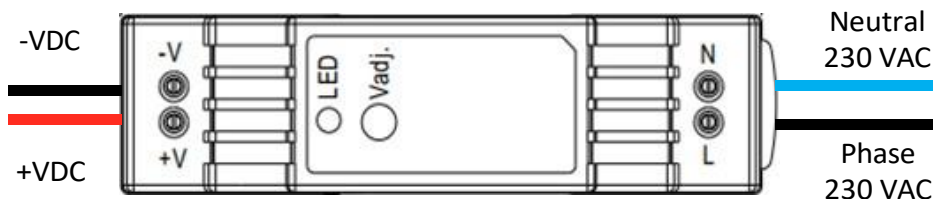

- | | |
|---|---|
|  | <ul style="list-style-type: none"> - Each wire connected to the power supply is labelled for identification. Do not connect in reverse order; it could cause irreparable damage on the Charge Point equipment. |
|---|---|

8.3.2 RFID LEGIC READER POWER SUPPLY (14) (OPTIONAL)

The RFID LEGIC reader power supply is a device that converts the 12Vdc voltage to 5Vdc to power the RFID LEGIC reader.



- | | |
|---|---|
|  | <ul style="list-style-type: none"> - Check output voltage at every Charge Point maintenance of, in order to ensure that all devices will work properly. - RFID LEGIC READER device will not work properly if the output of power supply is not at least 5V. |
|---|---|

8.3.2.1 TECHNICAL CHARACTERISTICS

A table of technical specifications of the power supply is shown below:

OUTPUT		INPUT	
DC Voltage	5 V	Voltage range	9...36 VDC
Rated current	3 A		
Current range	0...3 A	WEATHER CONDITIONS	
Rated power	15 W	Working temperature	-40...+85 °C
Voltage adj. range	4.5-5.5 V	Working humidity	5...95%

8.3.2.2 WIRING CONNECTION

Following image shows a detailed scheme of the power supply connections. Please, refer to “ TECHNICAL DATA” section for more details.

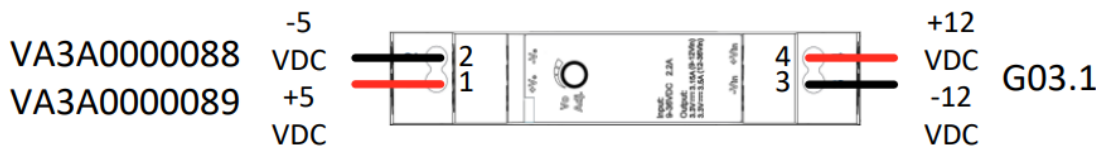

- | | |
|---|---|
|  | <ul style="list-style-type: none"> - Each wire connected to the power supply is labelled for identification. Do not connect in reverse order; it could cause irreparable damage on the Charge Point equipment. |
|---|---|

8.4 TAMPER SWITCH (18)

A tamper switch is a mechanical and electrical device connected to the frontal door that sends a warning if the door is partially or fully open.



The switch tamper has 3 positions:

- Plunger pulled: The frontal door is open, and a trained technician has pulled the plunger. The Charge Point will work as usual.
- Plunger not pushed: The frontal door is open. The Charge Point will detect an error and it will stop any charge transaction process.
- Plunger pushed: The frontal door is closed. The Charge Point will have a regular workflow.

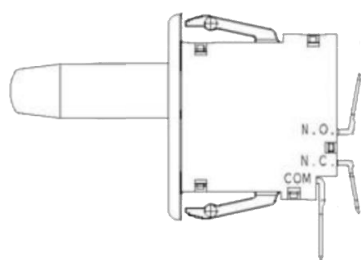

PLUNGER PULLED:
STATUS OK

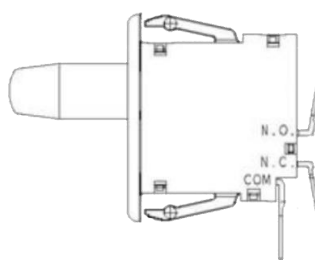

PLUNGER WITHOUT PRESSURE:
STATUS ERROR

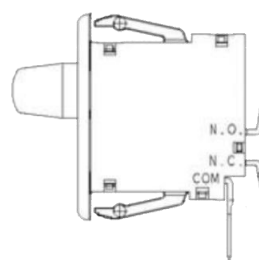

PLUNGER PUSEHD:
STATUS OK



Electrical risk: The Charge Point continues energized and all their components have electrical active parts that are accessible and energized.

8.4.1 WIRING

Following image shows a detailed schematic of the connections of the tamper in the CCL1-MINI PCB, refer to “8.4.2” section for more details

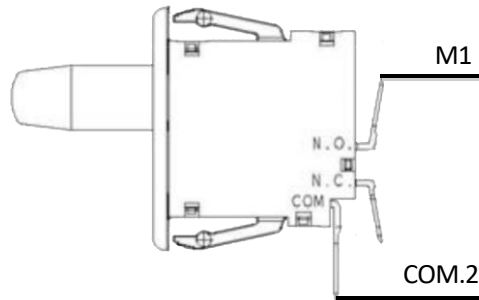

8.4.2 CCL1-MINI WIRING

Following image shows a detailed schematic of the connections in the CCL1-MINI PCB. Please, refer to “ TECHNICAL DATA” section for more details.

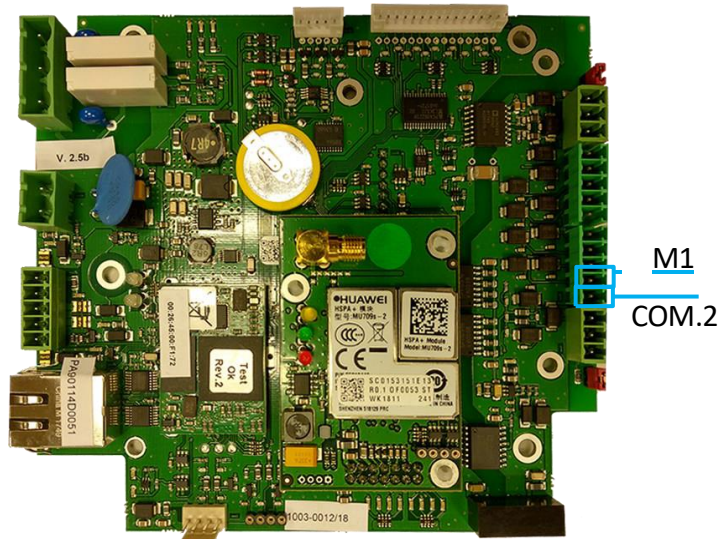

8.5 INTERFACE RGB BEACON LED CONVERTER BOARDS (29)

Interface LED is composed by two boards, one for each Charge Point plug/inlet.

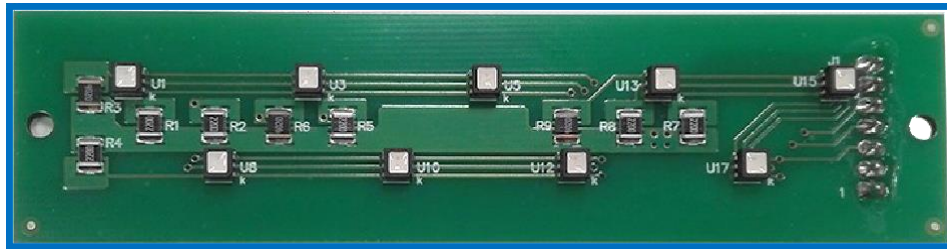

8.5.1 LED BOARD WIRING CONNECTION

Image below shows a basic scheme of the board wiring connections. Please, refer to “8.5.2” section for more details.

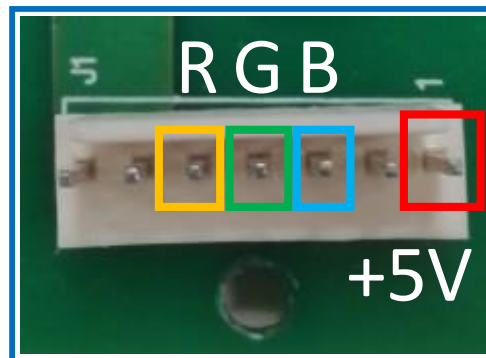

8.5.2 LED BOARD WIRING CONNECTION TO CCL1-MINI

Image below shows a basic scheme of the LED beacons in the CCL1-MINI PCB. Please, refer to “ TECHNICAL DATA” section for more details.

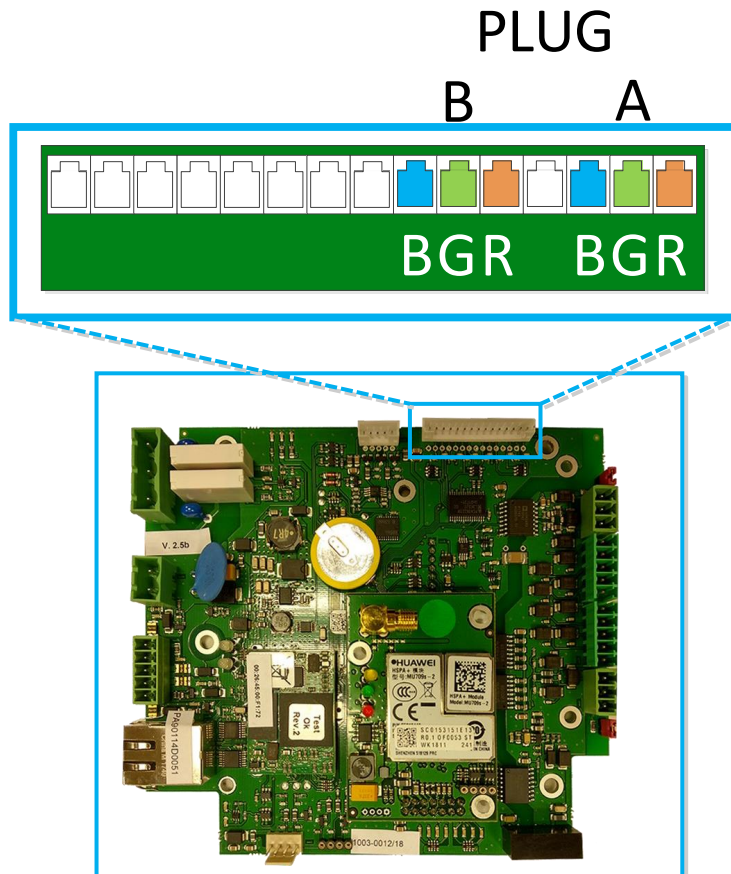

9 OPTIONAL DEVICES

This section describes in detail how to setup and replace quickly any device that can be found inside the Charge Point. The devices described here are optional for the Charge Point and may not be found in all the equipment:

- Locking system (4, 5)
- Plug shutter (8, 9)
- Type MIX 4 plugs TM4 (11, 12)
- RCD Type B self-reclosing (19 + 20)
- RCD Type B (20)
- Surge protection (21,23)
- Anti-vandal doors
- Anti-vandal key (31)

9.1 LOCKING SYSTEM (4,5)

Connector locking system is what blocks the connector in the Charge Point when a charging transaction is ongoing.

Charging transaction starts when a user that has been authorized (through the RFID) plugs the EV connector in the Charge Point.

The charging transaction continues even if the EV passes to state B (for example when the battery of the EV is full) therefore, the locking system remains active.

Charging transaction finishes when the user that has started the charging transaction identifies itself again in order to stop transaction. In Plug&Charge identification method case, the charge transaction finishes when the charge transaction is stopped from the EV.

There are two types of locking system, the monostable and by-stable systems. The difference between them is the perception of the position of the locking mechanism. The monostable system only knows if the locking mechanism is in the right position when it is activated and the by-stable system knows if the locking mechanism is in the right position on both cases, activated and deactivated.



This system locks the connector into the plug. Type 2, IEC 62196-2.

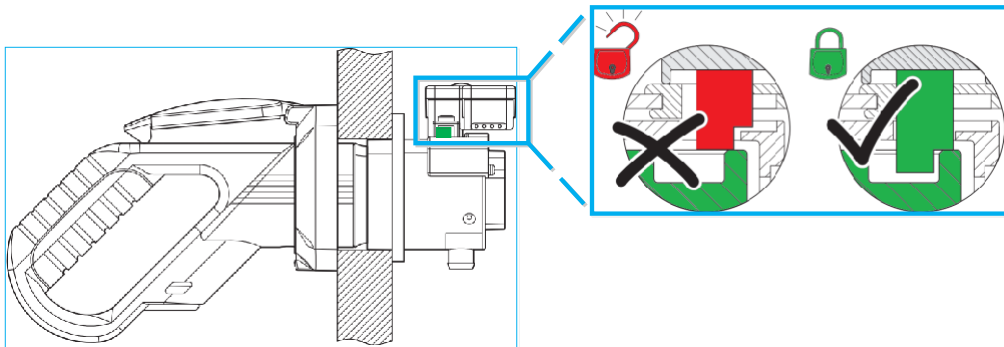

9.1.1.1 PERFORMANCE

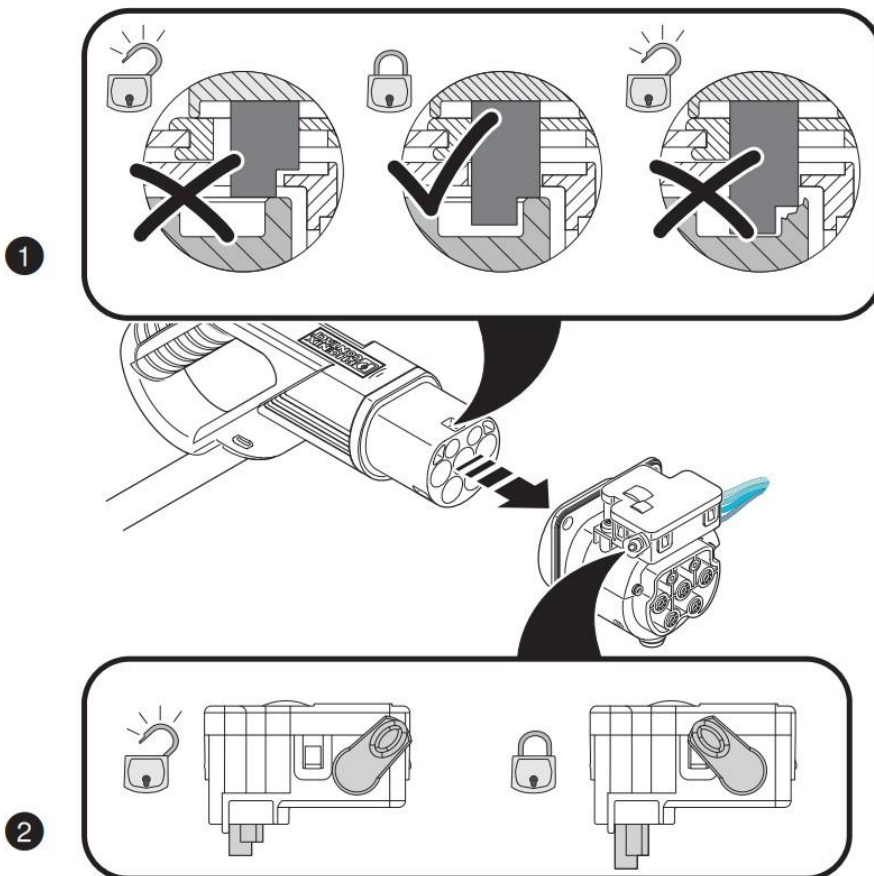

9.1.2 LOCKING SYSTEM WITH MONOSTABLE CONTROL

The locking system without shutter works with monostable control.

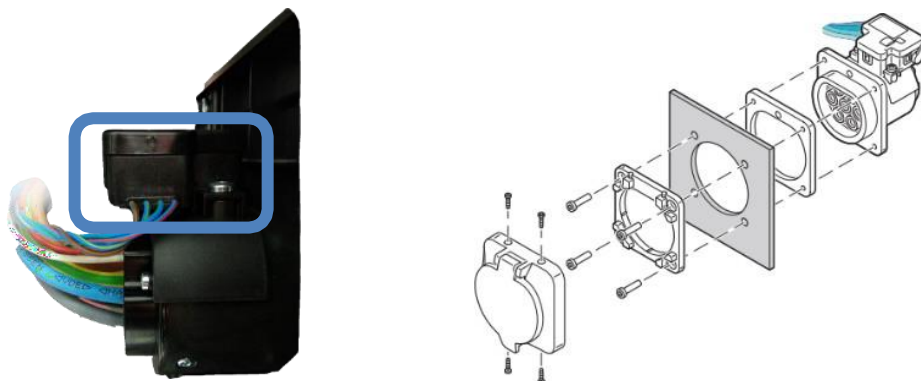

9.1.2.1 WIRING CONNECTION

Following image shows a detailed schematic of the connections. Please, refer to “TECHNICAL DATA” section for more details.

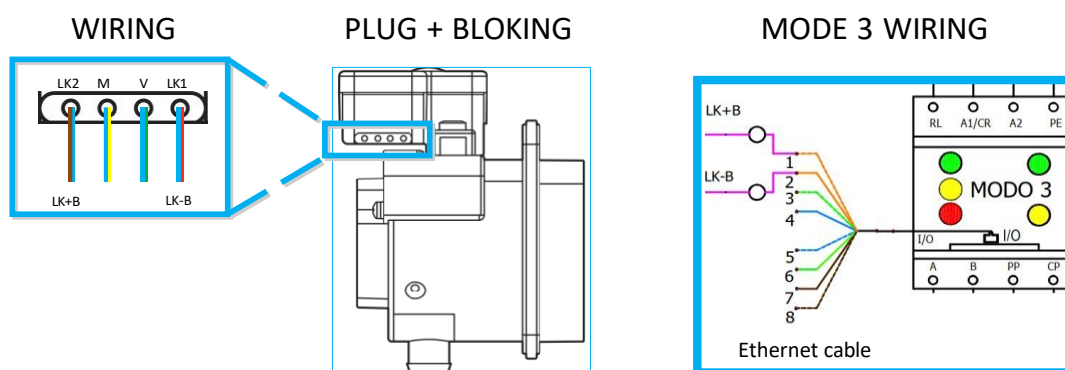

9.1.3 LOCKING SYSTEM WITH BISTABLE CONTROL

The locking system with shutter works with by-stable control.

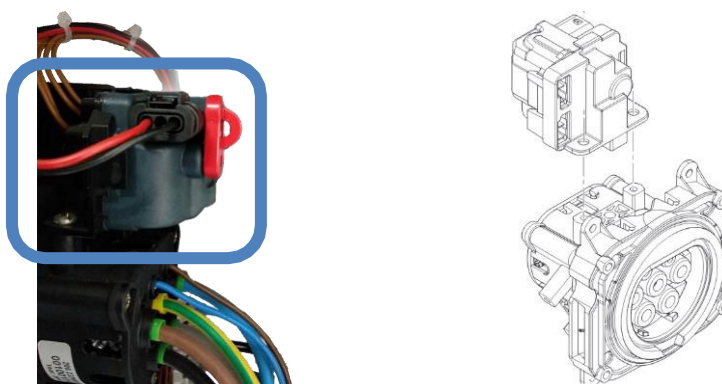

9.1.3.1 WIRING CONNECTION

Following image shows a detailed schematic of the connections. Please, refer to “TECHNICAL DATA” section for more details.

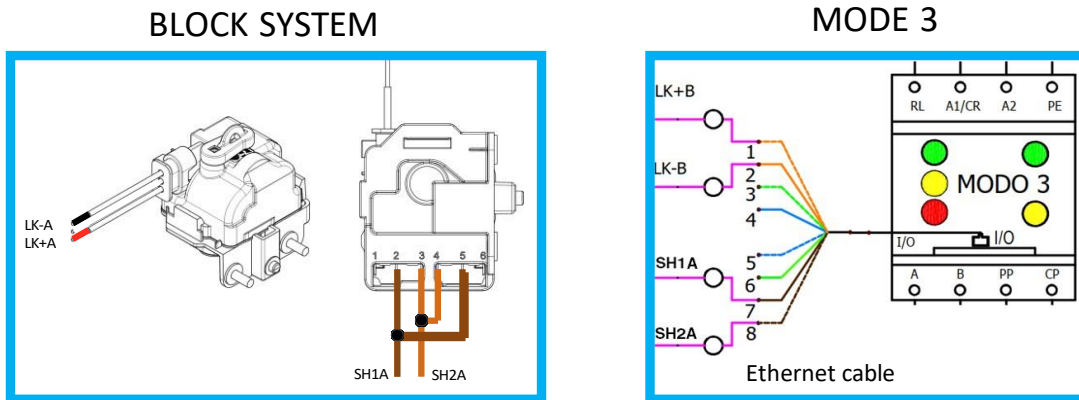

9.2 PLUG SHUTTER (8,9)

The Charge Point plugs have electrical active parts which can be accessible for non-qualified personnel that may involve an electrical risk for them. The plug shutter protects people from these electrical active parts, avoiding any risk.

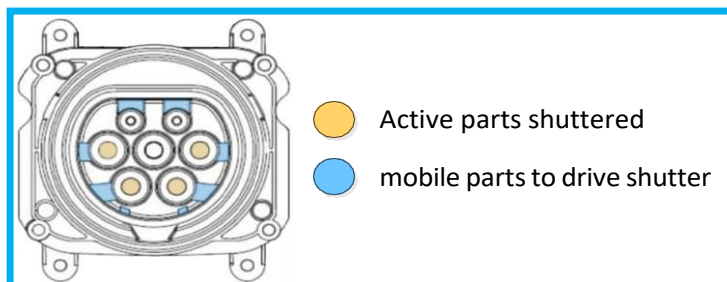
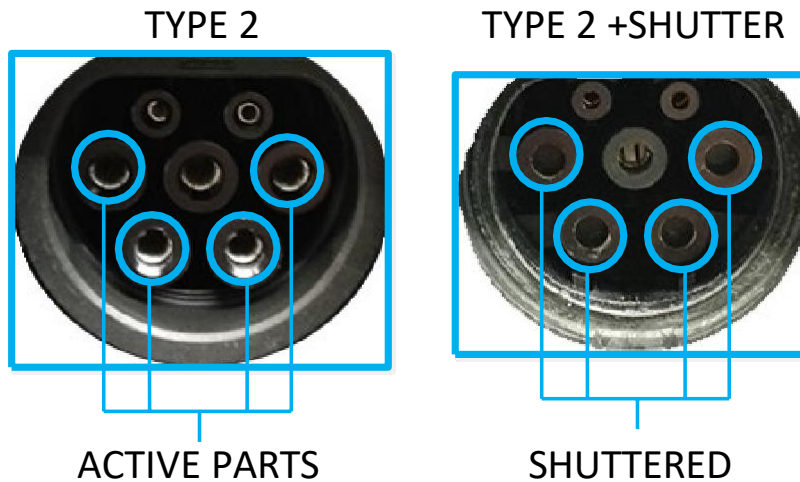

9.3 TYPE MIX 4 PLUGS TM4 (11,12)

The Charge Point eVolve Smart can have a configuration of one plug type 2 (IEC 62196-2) and one plug CEE 7/3 for each line of power. However, it can only be used simultaneously one of the two plugs per line of power.

Following image shows a detailed schematic of the connections. Please, refer to “TECHNICAL DATA” section for more details.

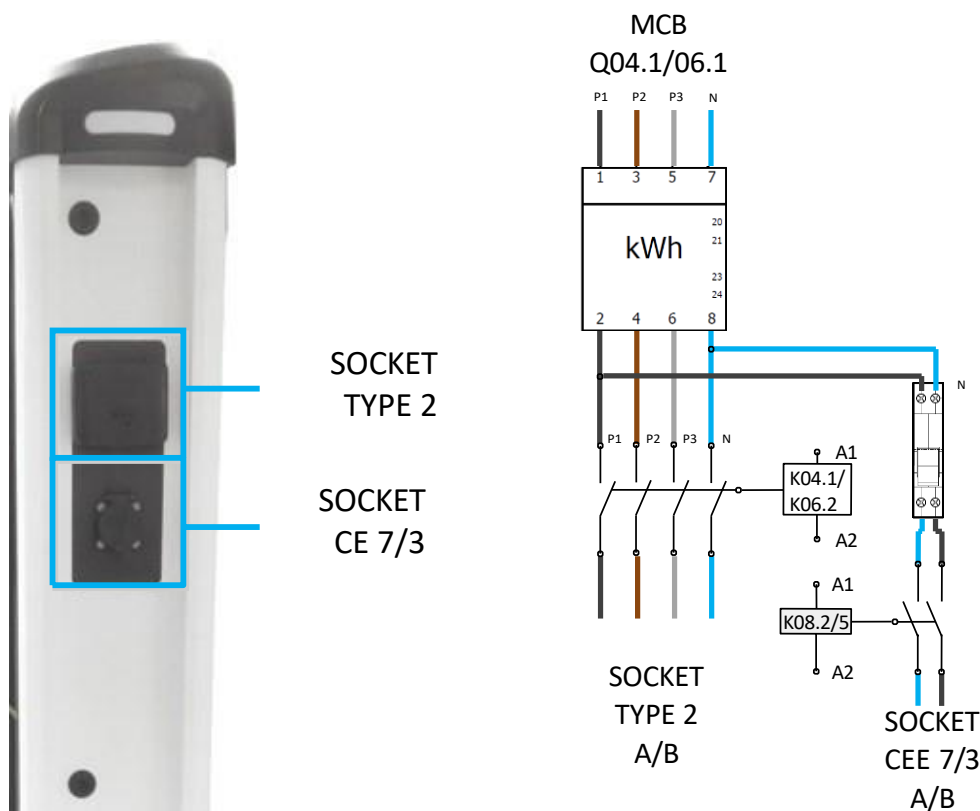

9.4 RCD TYPE B (20)

The RCD of the eVolve Smart Charge Point can be Type B.



9.4.1 TECHNICAL CHARACTERISTICS

A table of technical specifications of the RCD type B is shown below:

RCD TYPE B		
Residual current device	Type	B
	Sensitivity	30 mA
	Nominal current	40A
	Num. poles	4
	Protection against fault currents	Sinusoidal alternating currents and pulsating residual direct currents Sinusoidal alternating currents, up to 1 kHz Direct currents
Properties	Operating temperature	-25...+55 °C
	Dimensions	6,5 DIN modules
	Weight	693g

9.4.2 WIRING CONNECTION

Following image shows a detailed schematic of the connections. Please, refer to “TECHNICAL DATA” section for more details.

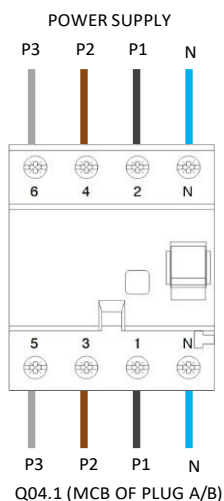

9.5 RCD SELF-RECLOSING (19 + 20)

The RCD for each plug can be self-reclosing.

9.5.1 TYPE A

The RCD Type A of the Charge Point eVolve Smart can be self-reclosing by replacing the default RCD Type A by a self-reclosing RCD Type A.



9.5.1.1 TECHNICAL CHARACTERISTICS

A table of technical specifications of the RCD Type A is shown below:

RCD TYPE A SELF-RECLOSING		
Residual current device	Type	A
	Sensitivity	30 mA
	Nominal current	40A
	Num. poles	4
Reclosing system	Number of reclosers	3
	Time between reclosers	3, 20, 180 s
Properties	Operating temperature	-25...+55 °C
	Weight	693g

9.5.1.2 RECLOSURE ATTEMPTS

The RCD with self-reclosing system attempts several times to reclose itself. In the table below it is specified the timings of the attempts after a residual current detection.

RECLOSURES					
1		2		3	
Delay	Restart	Delay	Restart	Delay	Restart
<3 sec.	10 sec.	20 sec.	20 sec.	180 sec.	60 sec.

9.5.1.3 RESTART IN CASE OF BLOCKING

In case of blocking of the unit, the re-start sequence is:

- 1 Put the mode selector switch in Manual Mode (OFF).
- 2 Lift the RCD cover
- 3 Put the RCD contact in mode ON.
- 4 Close the RCD cover.
- 5 Put the mode selector switch in Manual mode (ON).

Note: The switch has an M2 hole where you can attach a seal or a padlock to block the access to the RCD and any other attempts at manual reclosing.

9.5.1.4 WIRING CONNECTION

Following image shows a detailed schematic of the connections. Please, refer to “ TECHNICAL DATA” section for more details.

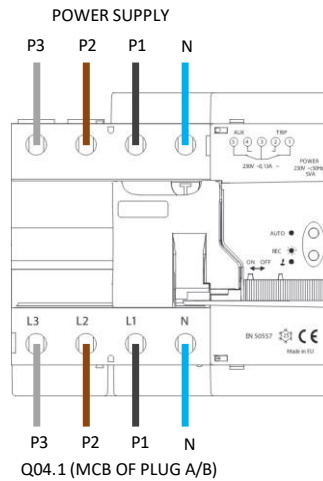

9.5.2 TYPE B – PHASE I

The RCD type B self-reclosing is composed by an MCB self-reclosing as a mechanical disconnecter and an earth leakage relay as an RCD.

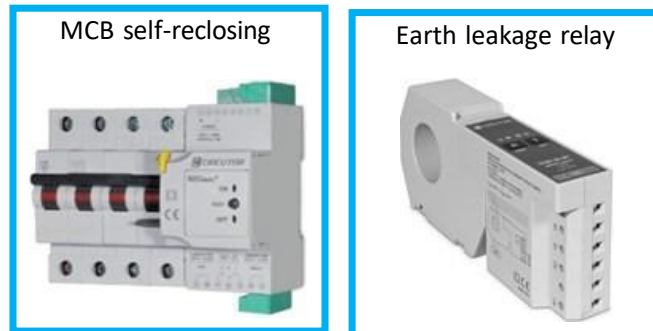

The tables of technical specifications of the MCB and the Earth Leakage Relay are shown below:

MCB SELF-RECLOSING		
MCB	Max Current	40 A
	Nominal cut-off power (IEC 947-2)	6 kA, in accordance with EN 60898 10 kA, in accordance with EN 60947-2
	Characteristic curve	C
	Rated working voltage	240 / 415 Vac
	Operating temperature	25 °C...+55 °C
	Working frequency range	50 ... 60 Hz
MP motor	Rated voltage	230 Vac ± 30%
	Closure time	< 1,000 ms
	Opening time	< 10 ms
Reclosing system	Number of reclosers	3
	Time between reclosers	180 s
	Reset time reclosers counter	30 m

EARTH LEAKAGE RELAY		
Circuit breaker protection	Class	B
	Sensibility	30 mA
	Max current	Up to 125 A
	Sensor	Built in earth leakage transformer 35 mm
	Test and Reset	T & R buttons
	Signalling LED	Power supply voltage Leakage trip
Mechanical Features	Operating temperature	-10...+50 °C
	Weight	380 g
	Terminal dimensions	1-1.5 mm ²
Electrical features	Operating voltage	230 Vac, 50/60 Hz

9.5.2.1 POWER SUPPLY WIRING CONNECTION

Following image shows a detailed schematic of the connections of the power supply to the MCB and the Earth Leakage Relay. Please, refer to “ TECHNICAL DATA” section for more details.

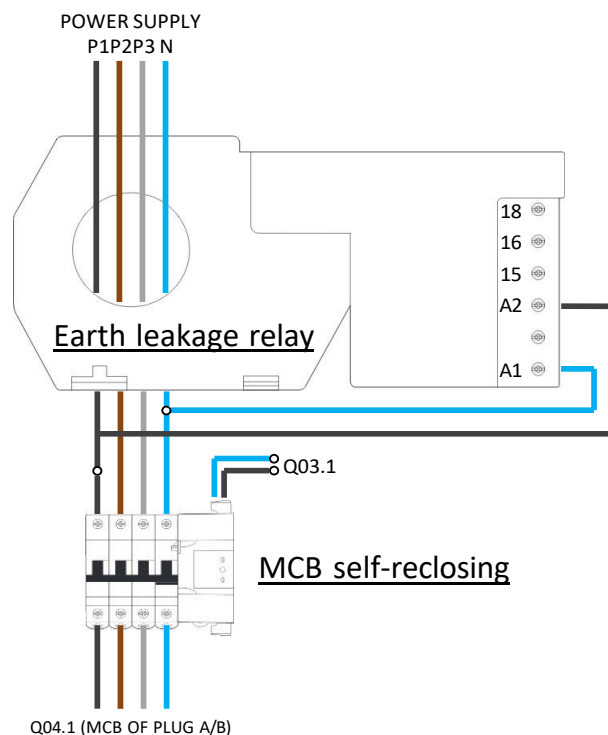

9.5.2.2 CONTROL WIRING CONNECTION

Following image shows a detailed schematic of the connections to the CCL1-MINI. Please, refer to “ TECHNICAL DATA” section for more details.

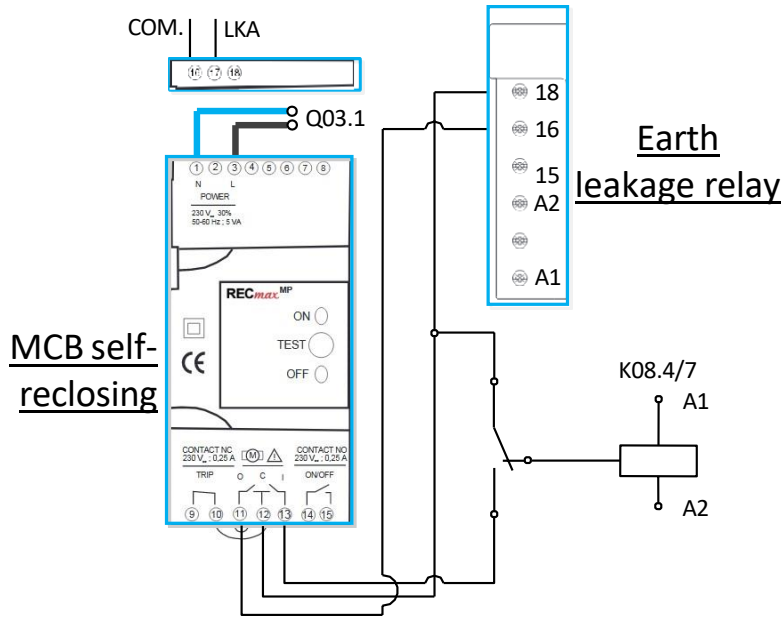

9.5.2.3 CCL1-MINI WIRING

Following image shows a detailed schematic of the connections in the CCL1-MINI PCB. Please, refer to “ TECHNICAL DATA” section for more details.

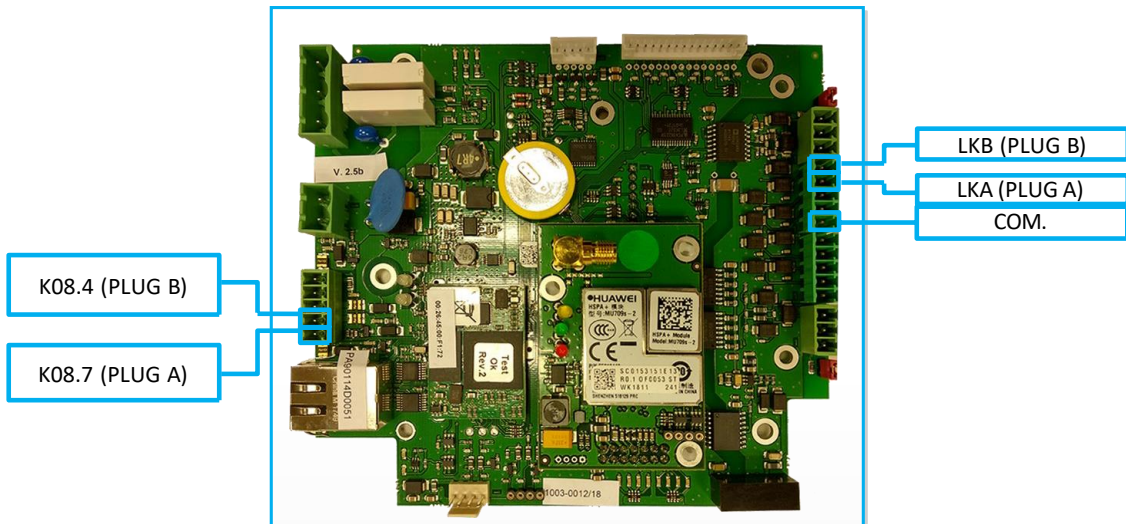

9.5.3 TYPE B – PHASE II

The RCD Type B self-reclosing is composed by a pilot self-reclosing RCD.

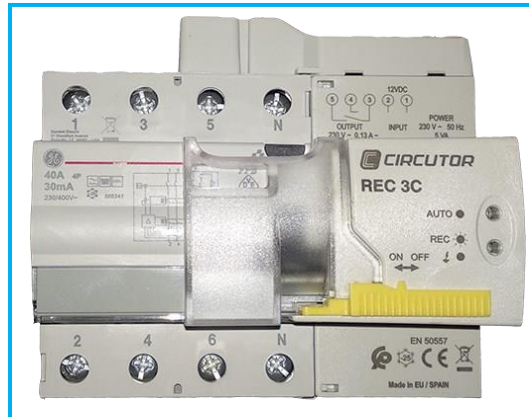

9.5.3.1 TECHNICAL CHARACTERISTICS

A table of technical specifications of the RCD Type B is shown below:

RCD TYPE A SELF-RECLosing		
Residual current device	Type	B
	Sensitivity	30 mA
	Nominal current	40A
	Num. poles	4

9.5.3.2 ELECTRICAL DIAGRAM

Following image shows a detailed schematic of the connections. Please, refer to “TECHNICAL DATA” section for more details.

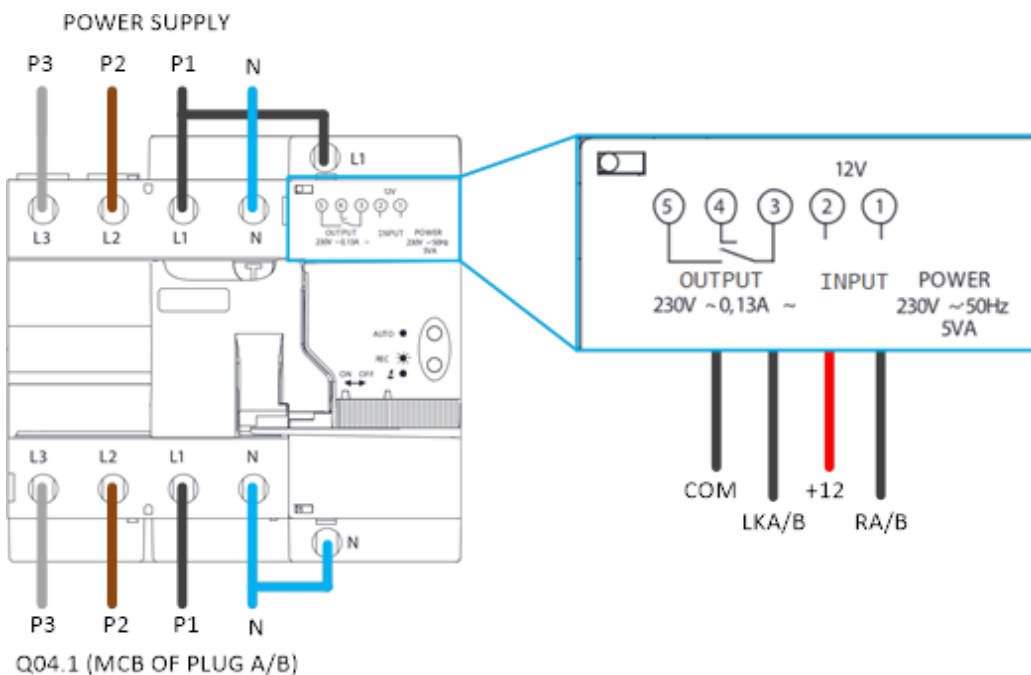

9.5.3.3 CCL1-MINI WIRING

Following image shows a detailed schematic of the connections in the CCL1-MINI PCB. Please, refer to “ TECHNICAL DATA” section for more details.

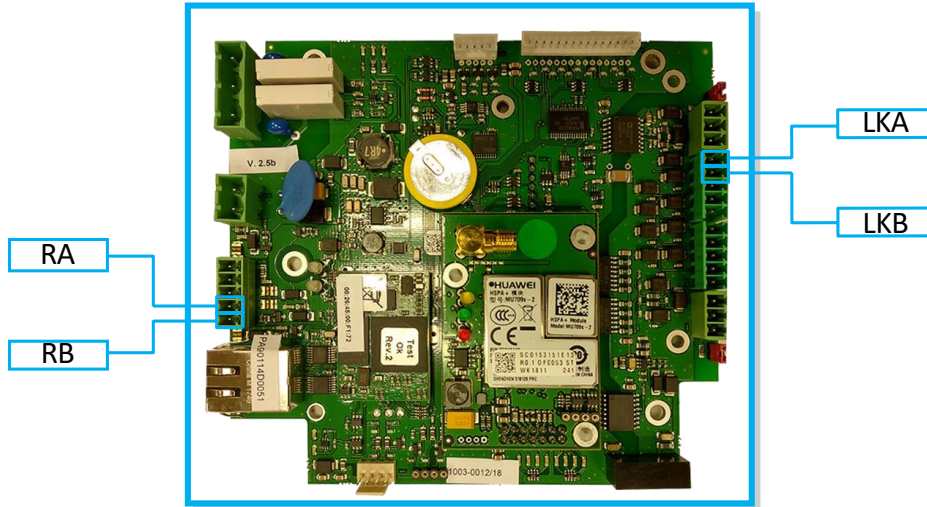

9.6 SURGE PROTECTION (21,23)

The surge protection has the capacity of discharging induced voltage surges. Suitable for the second level of protections in the supply distribution panels, in which Type I protectors are installed, or for the first level of protection for applications not exposed to direct strikes and with no external lightning protection system as defined by IEC 61643-11.

9.6.1 SURGE PROTECTION DEVICE



General			
Dimensions (HxWxL)	9x 7,2x 7	Num. poles	4
Weight	432gr	Network config.	TT, TNS
Designation according IEC 61643-11	Class II	Temperature range	-40°C+85°C

Technical features			
Supply voltage	230/400V	Maximum back-up fuse	125 A
Maximum discharge current (8/20) (L-PE) – I _{max}	40 kA	Short circuit withstand - I _{sc}	25 kA
Nominal discharge current (8/20) (L-PE) - I _n	20 kA	Response time (L-PE) – t _A (L-PE)	25 ns
Voltage protection level (L-PE) at I _n – U _p (L-PE)	1,3 kV	Remote indication	Yes

9.6.2 FUSE AS A SPAREPART

The fuses that are in the surge protection device can be replaced as a cartridge.

Fuse properties:

- Replaceable module
- Class 3
- Ph
- Rated current: 40 A (8/20)
- Rated voltage: 230 V



9.6.3 WIRING CONNECTION

The surge protections shall be wired in parallel to the main circuit in order to discharge the induced voltage surge.

Following image shows a detailed schematic of the connections. Please, refer to “TECHNICAL DATA” section for more details

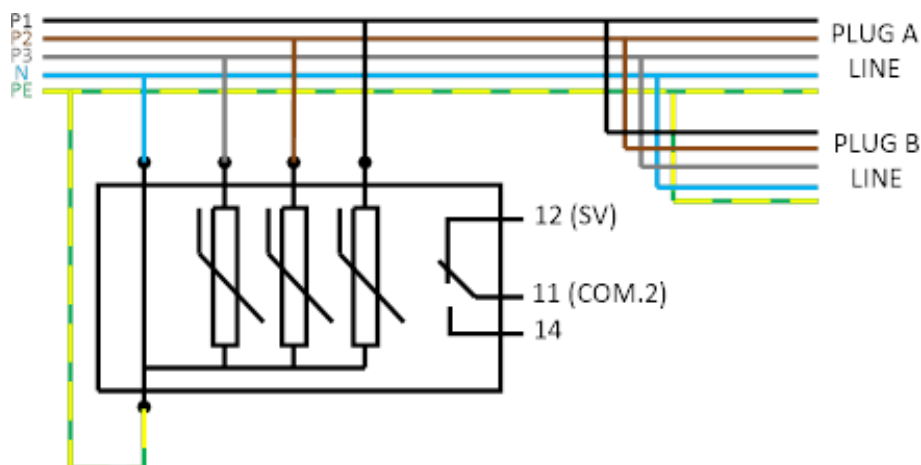

The input terminals of the power supply are designed to allow the surge protection circuit to be in parallel with the main circuit.

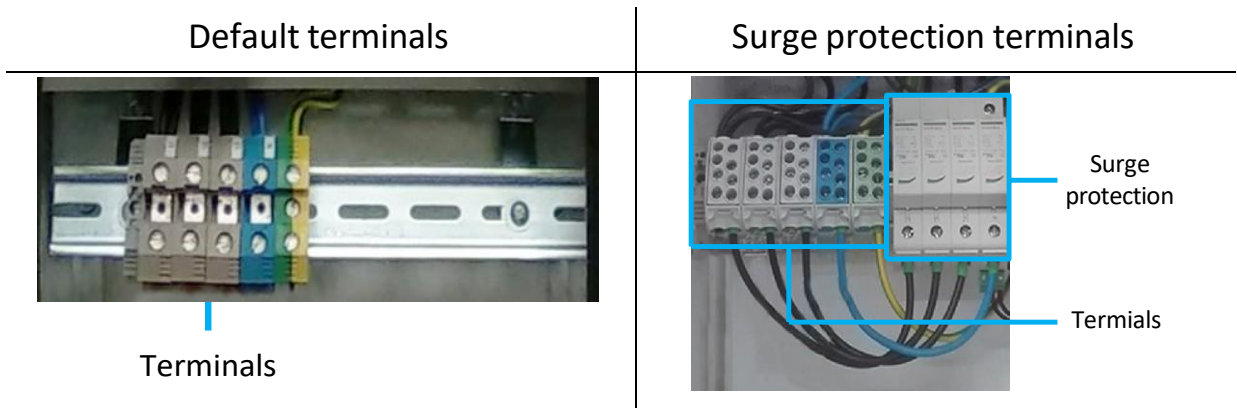

9.6.4 CCL1-MINI WIRING

Following image shows a detailed schematic of the connections in the CCL1-MINI PCB. Please, refer to “ TECHNICAL DATA” section for more details.

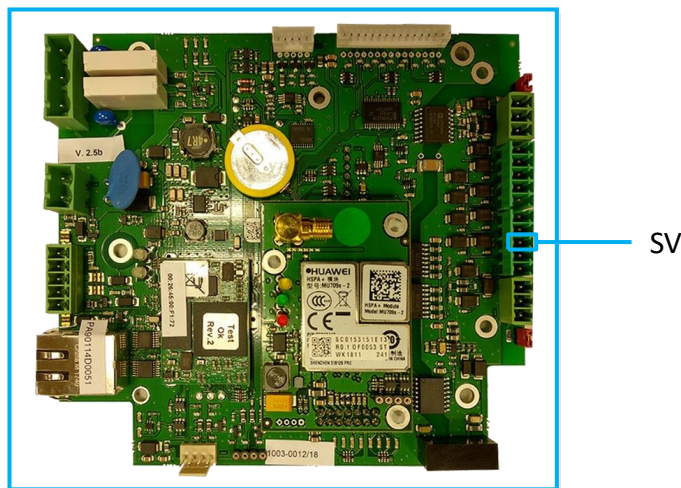

9.7 ANTI-VANDAL DOORS

Anti-vandal doors system is composed by three components which are used to avoid any vandal actions against the plugs or the electric parts.

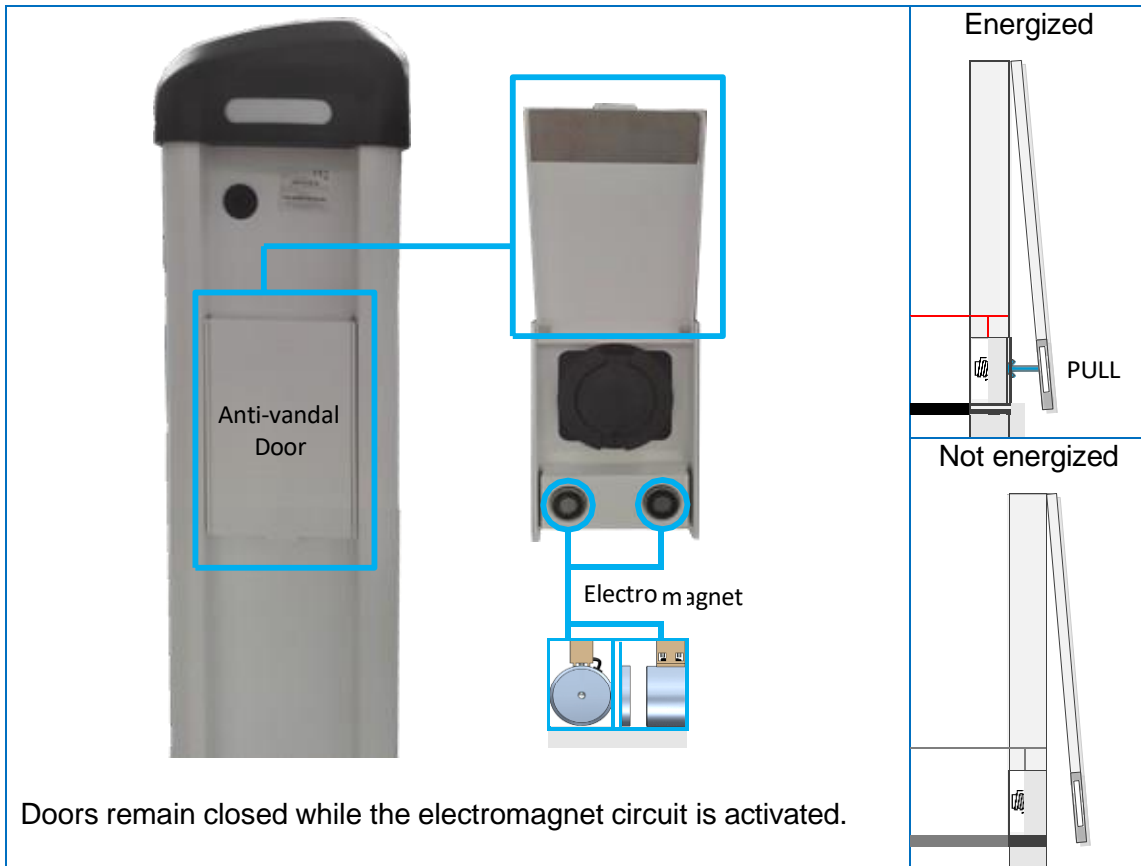

This circuit is controlled by the CCL1-MINI. Its digital outputs 1 and 2 are activated to energize an electromagnetic circuit through relays. These digital outputs are used to control the LED status of these plugs also.

Power supply:

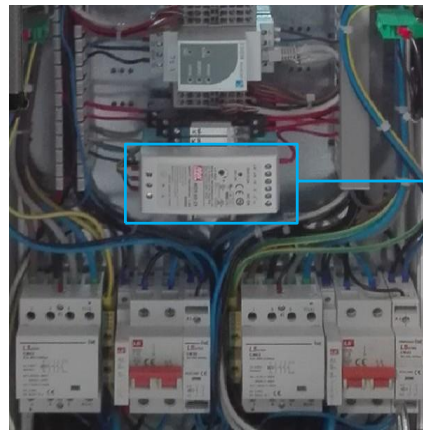

Power supply
24 Vdc

This power supply converts the 230Vac voltage to 24Vdc to power the electromagnetic circuit.



- Check output voltage at every Charge Point maintenance of, in order to ensure that all devices will work properly.
- Electromagnets will not work properly if the output of power supply is not at least 24V dc.

9.7.1 WIRING CONNECTION

Following image shows a detailed schematic of the connections. Please, refer to “9.7.2” section for the connection to the CCL1-MINI PCB or to “ TECHNICAL DATA” section for more details.

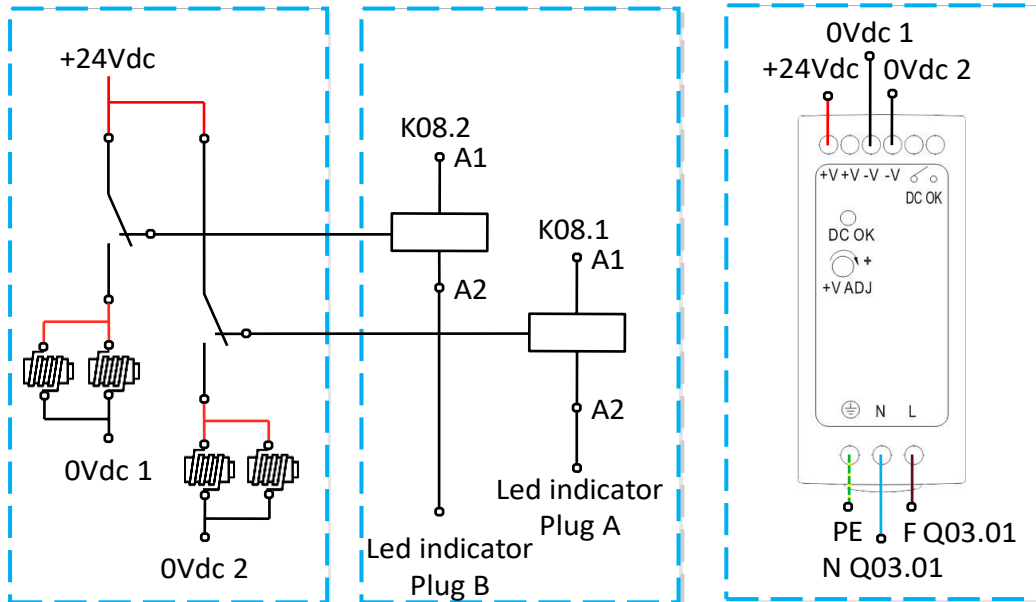

9.7.2 CCL1-MINI WIRING

Following image shows a detailed schematic of the connections in the CCL1-MINI PCB. Please, refer to “ TECHNICAL DATA” section for more details.

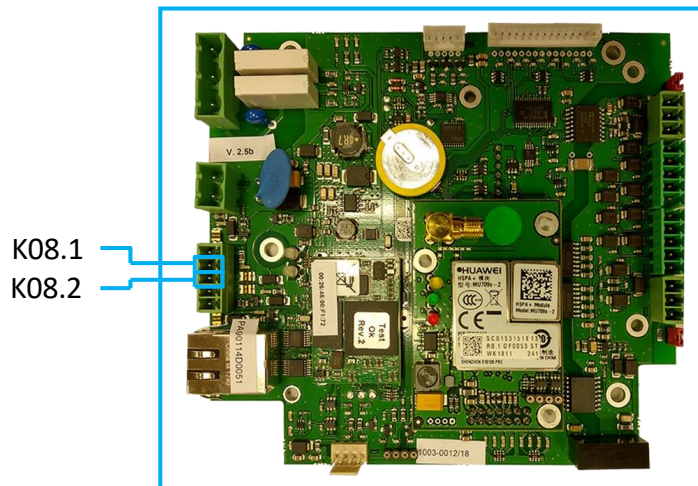



9.8 ANTI-VANDAL KEY (31)





The anti-vandal key feature is a lock key system to avoid the Charge Point to be opened by non-authorized personnel. The Charge Point lock system includes a regular key to open it. Therefore, only the person who has the key is able to open the Charge Point.

Key types needed:



9.8.1 HARDWARE REPLACEMENT PROCEDURE

STEP	ACTION
1	<p>Open the Charge Point and identify the lock that needs to be replaced.</p> 
2	<p>Disassemble the lock using the Tongue Groove Pliers and the Screwdriver.</p> 

3	<p>Place the isolation rubber as follows on the anti-vandal lock.</p> 
4	<p>Place the anti-vandal lock and assemble it with the Tongue Groove Pliers.</p> 
5	<p>Final position must be like in the picture below; otherwise it will not be possible to release the key from the lock system when opening and closing the door.</p> 
6	<p>Use the Screwdriver to assemble the whole mechanism.</p> 
7	<p>Check piston position to know if system is locked or unlocked.</p>

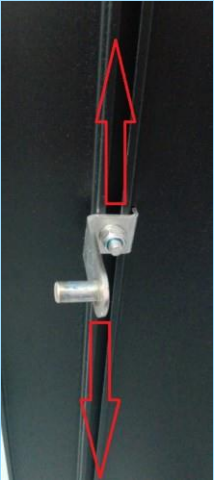
	UNLOCKED	LOCKED
8	<p>Try the functionality. You may need to adjust the position of the metallic piece in the door upwards or downwards.</p> 	
9	<p>Try functionality again. Perform the necessary adjustments on the mechanism and the metallic piece until everything works properly.</p>	
10	<p>Procedure has been completed</p>	

10 CHARGE POINT ADVANCED SETTINGS

10.1 CHARGE POINT MAXIMUM CURRENT OUTPUT

In case that the power supplied to the Charge Point is lower than the power that can be supplied by the Charge Point, the Charge Point can limit the maximum out-put current.

Use Charge Point Manager tool to set a lower current rate.



This section is dedicated only to the Charge Points with two socket/outlet Type 2.

Models affected:

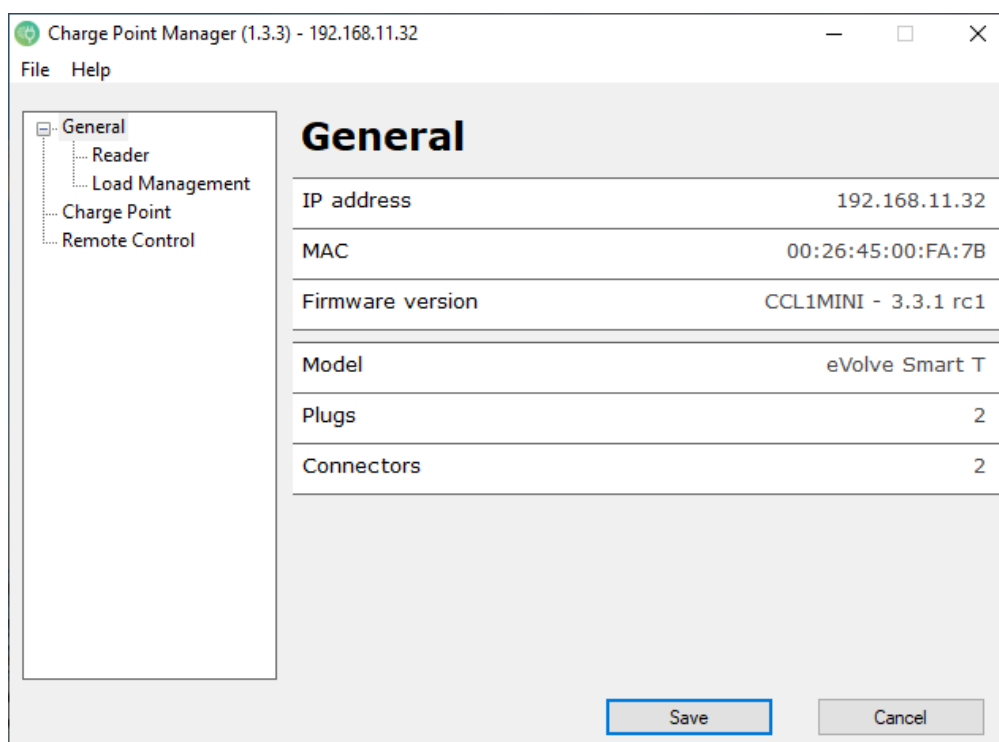
- Post eVolve Smart T
- Post eVolve Smart S
- Post eVolve Smart C63

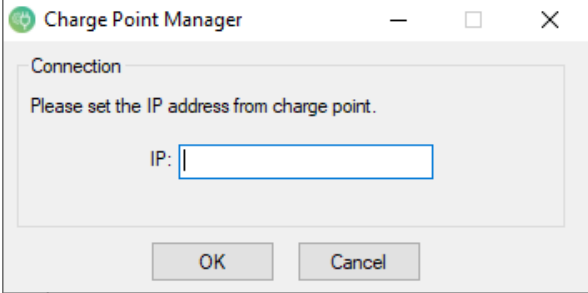
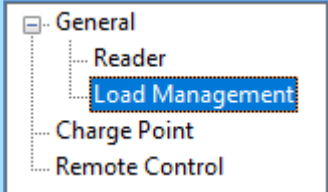

To change the Charge Point current rating, follow the steps below:

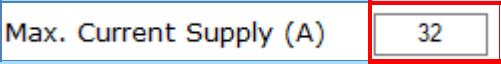
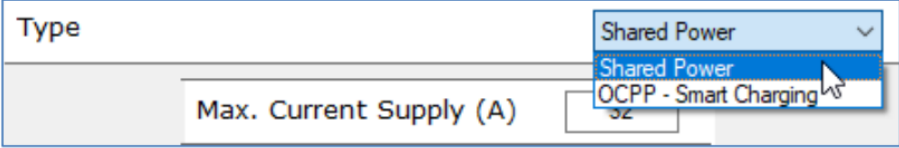
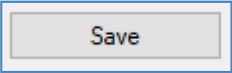
STEP	ACTION
1	<p>Set the IP address of the Charge Point.</p> <p>IP address shall be previously assigned using IPSetup.</p>  <p>The screenshot shows a dialog box titled "Charge Point Manager" with a "Connection" section. It contains the text "Please set the IP address from charge point." and an "IP:" label followed by an empty text input field. At the bottom are "OK" and "Cancel" buttons.</p>
2	<p>Select "Load management" at "General" menu.</p>  <p>The screenshot shows a tree view menu with "General" expanded. Under "General", there are four sub-items: "Reader", "Load Management" (which is highlighted with a blue selection box), "Charge Point", and "Remote Control".</p>
3	<p>Change the "Status" from disabled to enabled</p>  <p>The screenshot shows a "Status" dropdown menu. The current selection is "Enabled". The dropdown list is open, showing "Enabled" and "Disabled" options. A mouse cursor is pointing at the "Enabled" option.</p>
4	<p>Set the new current value to be applied at the Charge Point.</p>  <p>The screenshot shows a text input field labeled "Max. Current Supply (A)" with the value "32" entered. The input field is highlighted with a red rectangular border.</p>
5	<p>Make sure that "Shared Power" option is selected</p>  <p>The screenshot shows a "Type" dropdown menu. The current selection is "Shared Power". The dropdown list is open, showing "Shared Power" and "OCPP - Smart Charging" options. A mouse cursor is pointing at the "Shared Power" option.</p>
6	<p>Click the "Save" button and wait until the process ends.</p>  <p>The screenshot shows a single "Save" button.</p>

For further information please, refer to Charge Point Manager Instruction Manual.

10.2 CHARGE POINT MAXIMUM CURRENT OUTPUT FOR EACH PLUG

In case that the power supplied to the Charge Point is lower than the power that can be supplied by the Charge Point, the Charge Point can limit the maximum out-put current.

Use Charge Point Setup tool to set a lower current rate.

This section is dedicated only to the Charge Points with one socket/outlet Type 2.

Models affected:

- Post eVolve Smart T-one
- Post eVolve Smart S-one
- Post eVolve Smart C63-one

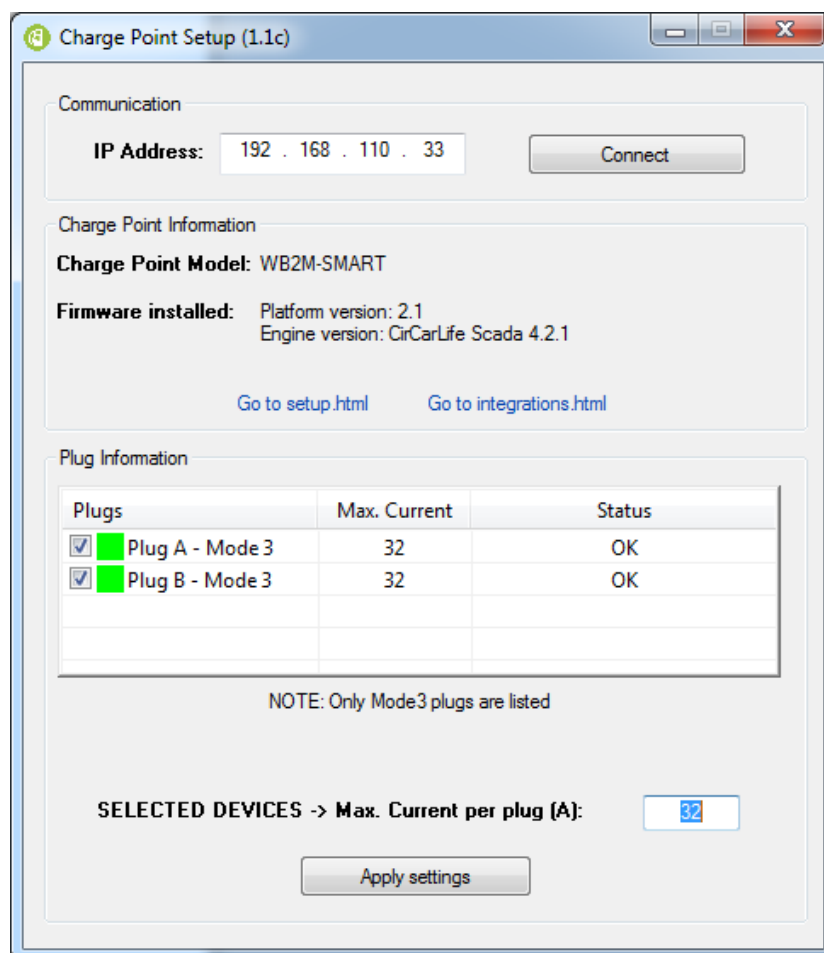

To change the Charge Point current rating, follow the steps below:

STEP	ACTION															
1	<p>Set the IP address from the Charge Point.</p> <p>IP address shall be previously assigned using IPSetup.</p> <div data-bbox="644 439 1155 555" style="border: 1px solid gray; padding: 5px; margin: 10px auto; width: fit-content;"> <p>Communication</p> <p>IP Address: <input type="text" value="192 . 168 . 110 . 33"/></p> </div>															
2	<p>Click on “Connect” button.</p> <div data-bbox="708 600 935 651" style="border: 1px solid gray; padding: 5px; margin: 10px auto; width: fit-content;"> <p>Connect</p> </div>															
3	<p>Select the desired plugs to modify the current value. By default, all plugs are selected.</p> <div data-bbox="496 815 1195 1086" style="border: 1px solid gray; padding: 5px; margin: 10px auto; width: fit-content;"> <p>Plug Information</p> <table border="1" style="width: 100%; border-collapse: collapse;"> <thead> <tr> <th style="width: 30%;">Plugs</th> <th style="width: 30%;">Max. Current</th> <th style="width: 40%;">Status</th> </tr> </thead> <tbody> <tr> <td><input checked="" type="checkbox"/> Plug A - Mode 3</td> <td style="text-align: center;">32</td> <td style="text-align: center;">OK</td> </tr> <tr> <td><input checked="" type="checkbox"/> Plug B - Mode 3</td> <td style="text-align: center;">32</td> <td style="text-align: center;">OK</td> </tr> <tr> <td> </td> <td> </td> <td> </td> </tr> <tr> <td> </td> <td> </td> <td> </td> </tr> </tbody> </table> <p style="font-size: small; text-align: center;">NOTE: Only Mode3 plugs are listed</p> </div>	Plugs	Max. Current	Status	<input checked="" type="checkbox"/> Plug A - Mode 3	32	OK	<input checked="" type="checkbox"/> Plug B - Mode 3	32	OK						
Plugs	Max. Current	Status														
<input checked="" type="checkbox"/> Plug A - Mode 3	32	OK														
<input checked="" type="checkbox"/> Plug B - Mode 3	32	OK														
4	<p>Set the new current value to apply on each plug.</p> <div data-bbox="517 1200 1238 1252" style="border: 1px solid gray; padding: 5px; margin: 10px auto; width: fit-content;"> <p>SELECTED DEVICES -> Max. Current per plug (A): <input style="width: 50px;" type="text" value="32"/></p> </div>															
5	<p>Click on “Apply settings” button and wait until the process ends.</p> <div data-bbox="730 1346 1003 1397" style="border: 1px solid gray; padding: 5px; margin: 10px auto; width: fit-content;"> <p>Apply settings</p> </div>															

For further information please, refer to Charge Point Setup Instruction Manual

NOTE: Charge Point Setup is available for the Charge Points with two socket/outlet type 2 but, if the current is limited by plug, the maximum current supplied by the Charge Point will be the most restrictive set by the CPS and CPM.

10.3 AUTHORIZATION MODE

Charge Point allows to choose between the following types of authorization:

- User: sends 1 authorization request to the central system. Select this option when OCPP is activated in the Charge Point.
- Plug: sends an authorization request for each plug that is in “available” status.

In order to change from one to another mode, follow the steps below:

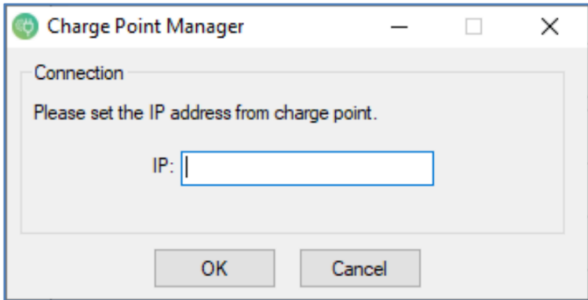
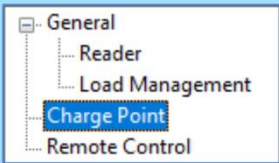
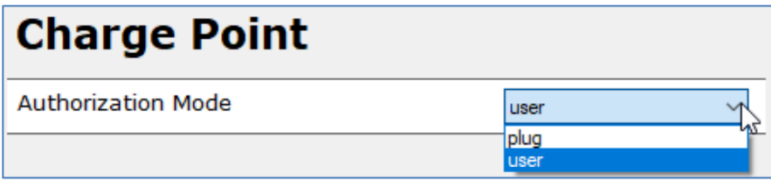
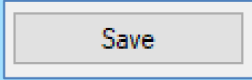
STEP	ACTION
1	<p>Set the IP address from the Charge Point.</p> <p>IP address shall be previously assigned using IPSetup.</p> 
2	<p>Select “Charge Point” at “General” menu.</p> 
3	<p>Choose the desired Authorization Mode.</p> 
6	<p>Click on “Save” button and wait until the process ends.</p> 

For further information please, refer to Charge Point Manager Instruction Manual.

11 REPLACEMENT PARTS

The EV Charge Point offers replacement parts to fix or update the Charge Point. Please, refer to the post-sales service for more information about the available spare parts at:

["support@circontrol.com"](mailto:support@circontrol.com)

12 ERRORS AND TROUBLESHOOTING

12.1 LCD MESSAGE ERRORS

Charge Point errors that affect the whole Charge Point:

DISPLAY MESSAGE	CAUSE
ERRORS VARS CFG	One or more variables from plug configuration are not configured correctly. Difference between component configurations in software and installed components
ERROR DRIVER COM	One or more devices are not communicating correctly.
ERROR TAMPER	Tamper activated. Charge Point detects its own door opened.
ERROR RCD	Outlet A or B RCD protection is tripped. (only in models with RCD trip monitoring)

There are also plug errors, which are related with only one of the plugs, so the other one may still work:

DISPLAY MESSAGE	CAUSE
PLUG A: ERROR VARS CFG	One or more variables from plug configuration are not configured correctly. Difference between component configurations in software and installed components
PLUG A: ERROR DRIVER COM	One or more devices from the plug affected are not communicating correctly.
PLUG A: ERROR RCD	Outlet A or B RCD circuit protection is tripped. (only in models with RCD trip monitoring)
ERROR MCB	Outlet A or B MCB circuit protection is tripped. (only in models with MCB trip monitoring) Plug A or Plug B.

12.1.1 ERRORS VARS CFG

CONCEPT

One or more variables from plug configuration are not configured correctly. There are differences between component settings in software and installed components.

SOLUTION

- Obtain the latest firmware version of CCL1-MINI from Circontrol Expert Area.
- Update the firmware version of the CCL1-MINI through the web setup to the latest version. <http://<IP>/services>

CCL1-MINI firmware version 2 or previous CCL1-MINI firmware version 3 or later

Information	
MAC	00:26:45:00:xx:xx
Version Upgrade	2.xx
Powerstudio version	4.x.x
Upload Configuration	
Devices status	
Modem status	

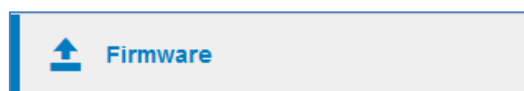

- Contact the Post-Sales department to provide you with a software version corresponding to the Charge Point and optional components configuration.
- Update the software version through the web setup to the latest version. <http://<IP>/services>

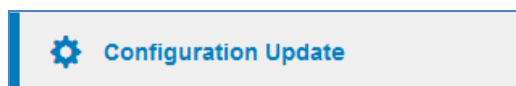

12.1.2 ERROR DRIVER COM

CONCEPT

One or more devices are not communicating properly.

SOLUTION

In order to identify the device that is not communicating, check the communication of the devices in the next URL from the Charge Point: <http://<IP>/services/>

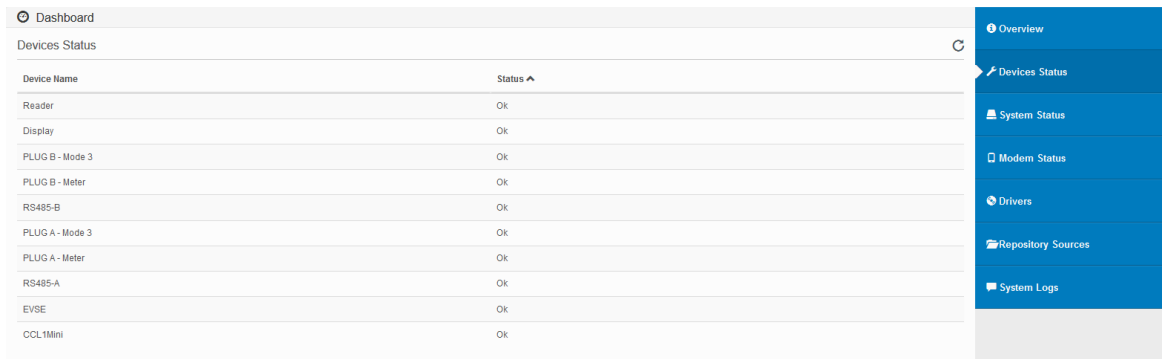

Device Name	Status ^
Reader	Ok
Display	Ok
PLUG B - Mode 3	Ok
PLUG B - Meter	Ok
RS485-B	Ok
PLUG A - Mode 3	Ok
PLUG A - Meter	Ok
RS485-A	Ok
EVSE	Ok
CCL1Mini	Ok

The devices that are not communicating appear with the “error time out” status.

Common steps:

- Check if the device is powered and if the wiring is ok.
- Check if the device has the right peripheral number and the baud rate speed communication.
- If the communication error is intermittent, it could be caused by a protection earth issue. In that case, the electric noise of the PE wires may affect the communication wires. In order to solve it, separate as much as possible the communication wires from the PE wires.

Energy Meter: Follow the steps shown in “ENERGY METER (17)” section to set the Charge Point energy meter. If the Energy meter does not have setup steps, contact the Post-sales department to provide you with a solution.

RFID reader: Follow the steps in “RFID READER (27)” section. In case of product distribution change from phase I to phase II, contact the Post-sales department to provide you with a solution.

LCD: In case of distribution change from phase I to phase II, contact the Post-sales department to provide you with a solution.

MODE 3 DIN RAIL: In case of distribution change from phase I to phase II, contact the Post-sales department to provide you with a solution.

12.1.3 ERROR TAMPER

CONCEPT

The tamper detects an error when the door is open.

SOLUTION

When the Charge Point is open, tamper switch notifies it and the Charge Point switches to an error state.

The tamper switch has three positions:

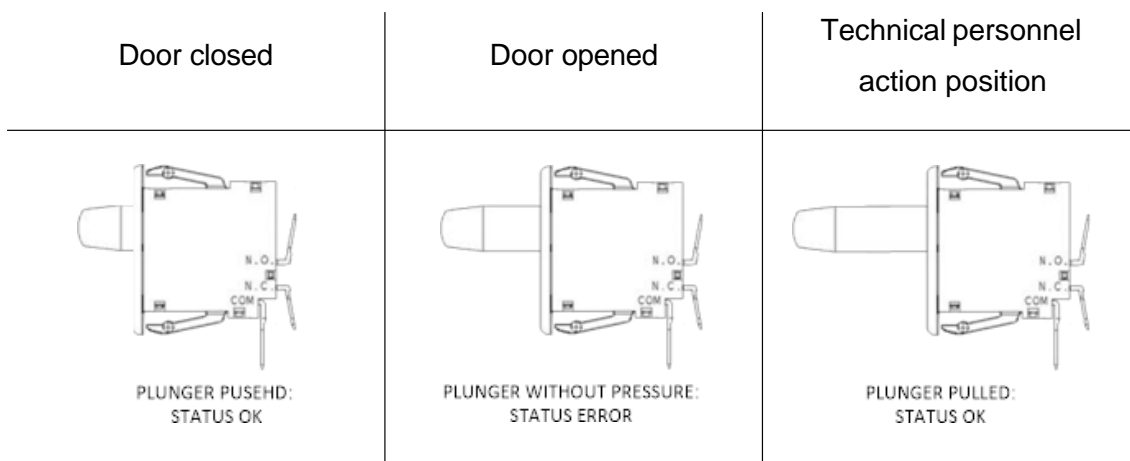

If the tamper switch is in “Plunger pulled” position and the error continue, check the wiring.

For further information, please refer to “TAMPER SWITCH (18)” section.

12.1.4 ERROR RCD

CONCEPT

Outlet A or B RCD protection is tripped. (Only in models with RCD trip monitoring).

SOLUTION

Check if any electrical issue is taking place in the Charge Point.

After the error is solved or if any error has been detected, rearm the RCD protection.

12.1.5 ERROR MCB

CONCEPT

Plug A or Plug B MCB protection is tripped. (Only in models with MCB trip monitoring).

SOLUTION

Check if any electrical issue is taking place in the Charge Point.

After the error is solved or if any error has been detected, rearm the MCB protection.

12.2 OCPP 1.5 COMMON ERRORS

CONCEPT

After applying new settings, please go to next URL from Charge Point in order to check the proper connection of the integration chosen:

<http://<IP>/services/cpi/log?app=ocpp1.5>

Look especially for the following messages:

```
Jan 10 14:55:49 (none)user.debug ocpp1.5: Registering CB after boot
Jan 10 14:55:49 (none)user.info ocpp1.5: Setting heartbeat interval to 300 s
Jan 10 14:55:49 (none)user.info ocpp1.5: Heart-beat interval changed to 300
Jan 10 14:56:09 (none)user.debug ocpp1.5: Synchro date: Done
Jan 10 14:56:09 (none)user.info ocpp1.5: OCPP time synchronization
Jan 10 14:56:09 (none)user.info ocpp1.5: CB boot notification: success
```



If **'CB boot notification: success'** appears when the Charge Point is properly connected to the Central System.

Otherwise, if the message shown is **'Registering CB in the CS: failed'** then check following list of errors:

12.2.1 Connect failed in tcp_connect

Example:

```
Sep 7 08:55:15 (none) user.err ocpp1.5: OcppCsEngine.cpp:254 - Registering CB in the CS: failed
Sep 7 08:55:15 (none) user.err ocpp1.5: OcppCsClient.cpp:197 - Notifying Boot - 28, SOAP-
ENV:Sender, , , connect failed in tcp_connect()
```

Common causes:

The host URL introduced is not correct. Check it on the OCPP configuration.

- Check if embedded modem is connected to the network. Otherwise check modem parameters (some cellular providers require special APN configuration).
- If there is no modem. Then ethernet IP address shall be static, using gateway and DNS from this network. Do not use DHCP=ON

12.2.2 Notifying Boot - 200

Example:

```
May 8 14:49:45 eds user.err ocpp1.5: OcppCsClient.cpp:197 - Notifying Boot - 200, , , ,
```

```
May 8 14:49:45 eds user.err ocpp1.5: OcppCsEngine.cpp:254 - Registering CB in the CS: failed
```

Common causes:

- CS should check if Charge Point is added in their side.
- Check Charge Point ID within OCPP configuration on CP side.

<http://<IP>:8080/html/setup.html>

12.2.3 Notifying Boot - -1

Example:

```
Jun 9 15:50:46 eds user.err ocpp1.5: OcppCsClient.cpp:197 - Notifying Boot - -1, , , ,
```

```
Jun 9 15:50:46 eds user.err ocpp1.5: OcppCsEngine.cpp:254 - Registering CB in the CS: failed
```

Common causes:

There is a filter on the network related with the size of the messages sent from the Charge Point (I could be in the SIM card side on in the CS). This filter cause that the message, or part of the message is not sent to the CS, therefore, information is not completely delivered. That problem can be solved adjusting the MTU to a lower value. Default value is 1500 bytes, and it could be adjusted to 1000 or 1200 bytes. By doing that, the problem would be solved, as the size of the messages would be smaller than the filter.

- Ask SIM card provider to adjust the MTU value to 1000 or 1200 bytes.

12.2.4 HTTP/1.1 404 Not Found

Example:

```
Mar 15 11:23:09 eds user.err ocpp1.5: OcppCsClient.cpp:197 - Notifying Boot - 404, SOAP-  
ENV:Server, SOAP-ENV:Server, HTTP/1.1 404 Not Found,
```

```
Mar 15 11:23:09 eds user.err OcppCsEngine.cpp:254 - Registering CB in the CS: failed
```

Common causes:

Charge Point reaches the CS and cannot log in:

The Host URL introduced is not correct. Please, revise it and make sure it is properly written. Take into account that it is case sensitive: <http://<IP>:8080/html/setup.html>

12.2.5 Cannot get charge device name

Example:

```
Sep 7 08:55:15 eds user.err ocpp1.5: Cannot get charge device name
```

Common causes:

- The internal application of the Charge Point is corrupted/lost or not installed.
- It requires to upload a file provided by Post-sales support in the *Configuration Update* section on the web page of the Charge Point.

12.2.6 SSL/TLS error

Example:

```
Sep 7 08:55:15 eds user.err ocpp1.5: Initializing CS client - 30, SOAP-ENV:Server, SOAP-ENV:Server, SSL/TLS error
```

Common causes:

HTTPS URL's requires a certificate that shall be uploaded to the OCPP integrations webpage.

- The Certificate uploaded is not correct.
- Time and Date are not correctly synchronised.

12.2.7 'Detail: bind failed in soap_bind / 'Error 28'

Example:

```
Oct 19 12:56:41 raption user.err ocpp1.5: OcppCbServer.cpp:224 - CP server: SOAP 1.2 fault: SOAP-ENV:Receiver [no subcode] "" Detail: bind failed in soap_bind() - Err. Code: 28
```

```
Oct 19 12:56:41 raption user.err ocpp1.5: OcppCbServer.cpp:164 - CB OCPP Server - Failed to start - Retries: 14
```

Common causes:

- OCPP Listening Ports configured already used by default by the unit: 80, 8080, 65432, 22.

12.2.8 Getting valid public ID timeout

Example:

```
Jul 26 10:25:42 raption user.err ocpp1.5: OcppCsClient.cpp:1059 - Failed to open /etc/public_address
Jul 26 10:25:42 raption user.err OcppCsClient.cpp:1076 - Getting valid public ID timeout. Using null IP
for OCPP message headers
```

Common causes:

- Check if “Network -> Public Address Manager” is selected as *Embedded modem*
- Check with the SM card provider if the SIM card is activated (in some cases Roaming is required too).

12.2.9 No Data, get host by name failed in tcp_connect()

Example:

```
Oct 19 12:56:41 raption user.err ocpp1.5: OcppCsClient.cpp:209 - Notifying Boot - 28, SOAP-
ENV:Sender, , No Data, get host by name failed in tcp_connect()
Oct 19 12:56:41 raption user.err ocpp1.5: OcppCsEngine.cpp:173 - Registering CB in the CS: failed
```

Common causes:

Hostname cannot be resolved in the Charge Point side:

<http://<IP>:8080/html/setup.html>

- Check if embedded modem is connected to the network. Otherwise, check modem parameters (some cellular providers require especial APN configuration).
- If no modem, ethernet IP address shall be static, using gateway and DNS from this network. Do not use DHCP=ON.

12.3 OCPP 1.6 COMMON ERRORS

After applying new settings, please go to the following URL from Charge Point in order to check the proper connection of the integration chosen:

<http://<IP>/services/cpi/log?app=ocpp1.6>

Look especially for the following messages:

```
Nov 19 11:46:32 raption user.info ocpp1.6: BootNotification result: Accepted
Nov 19 11:46:32 raption user.info ocpp1.6: Setting heartbeat interval to 120 s
Nov 19 11:46:32 raption user.info ocpp1.6: Time synchronization after boot notification
Nov 19 11:46:32 raption user.debug ocpp1.6: Synchro date: Done
Nov 19 11:46:32 raption user.info ocpp1.6: OCPP time synchronization
```

If **'BootNotification result: Accepted'**: Charge Point is properly connected to the Central System.

Otherwise, if the message shown is **'Registering CB in the CS: failed'**, check the following list of errors and refer to the following URL:

<http://<IP>:8080/html/setup.html>

12.3.1 CS Connection FAILED. Fail reason: Underlying Transport Error

Hostname cannot be resolved in the Charge Point side:

The host URL introduced is not correct. Check it in the OCPP configuration.

- Check if embedded the modem is connected to the network. Otherwise, check modem parameters (some cellular providers require special APN configuration).
- If there is no modem, ethernet IP address shall be static, using the gateway and DNS from this network. Do not use DHCP=ON.

12.3.2 CS Connection FAILED. Fail reason: Timer Expired

Charge Point has resolved the DNS of the URL but it is not able to reach CS.

- Check if the embedded modem is connected to the network. Otherwise, check modem parameters (some SIM card providers require special APN configuration).
- If there is no modem, then ethernet IP address must be static, using gateway and DNS from this network. Do not use DHCP=ON.

12.3.3 CS Connection FAILED. Fail reason: Invalid HTTP status

The Charge Point reaches the CS, but it has rejected the Charge Point ID configured.

- CS should check if Charge Point has been added in their side.
- Check Charge Point ID in the OCPP configuration on CP side.

13 MAINTENANCE

The Charge Point needs regular maintenance and components inspection during its lifespan.

Before starting the maintenance or a component replacement procedure, disconnect the Charge Point from any power source.

Pay attention to the following symbols to prevent electrical hazard.



When performing some inspection and service at the equipment, except if it is necessary, make sure that all circuit breakers are switch OFF before start working.

The Charge Point contains electric, mechanical and consumable components that shall be periodically checked, in order to keep the properly performance of the Charge Point and keep it in the best conditions throughout its useful lifetime.

This section specifies how to perform the preventive maintenance, its frequency and the components that shall be verified.

Please, see the “Wear check list AC Charge Points” in the “13.1-Verification documents” section to perform the first inspection of the Charge Point.

To carry out the preventive maintenance, please see the “Preventive maintenance AC Charge Points” list in the “ VERIFICATION DOCUMENTS” section.

The maintenance plan is based on years from the start-up, hours of charging or standby, and cycles of charging. Depending on the group of components, it is necessary to apply a specific maintenance timing. Check the periods in the tables below:

Maintenance	6 months	1 year	2 years	3 years	4 years	5 years
Wear-check inspection	●	●		●		●
Preventive maintenance	○	●	●	●	●	●

- Standard intervals.
- Special intervals for very dusty environments as deserts. Repeat the interval of period indicated after each task of maintenance.

Inspection of components	3 months	1 year	2 years	3 years	4 years	5 years
Contactors			●		●	
MCB				●		

The table above has been calculated according to the frequency of use of a Charge Point that performs 10 charge transactions per day.

Components inspection	10.000h	20.000h	30.000h	40.000h	50.000h	60.000h	70.000h
Contactors	●		●		●		
MCB					●		

“Wear-check inspection” and “Preventive maintenance” lists are in next section and available in Circontrol Expert Area. If further information is requested, please, contact with the Post-Sales department (support@circontrol.com).

13.1 VERIFICATION DOCUMENTS

Depending on the Post eVolve Smart version that you have been provided, there exists different schematics and different consultant documents. If any of them are needed, please contact CIRCONTROL’s post-sales service.

- Preventive maintenance
- Wear Check inspection

PREVENTIVE MAINTENANCE AC CHARGE POINTS

<i>Maintenance Information</i>			
Contractor:	<input style="width: 90%;" type="text"/>	Contract nº:	<input style="width: 90%;" type="text"/>
Maintenance Hired:	<input style="width: 90%;" type="text"/>	Ticket nº:	<input style="width: 90%;" type="text"/>
Client / Operator:	<input style="width: 90%;" type="text"/>	Maintenance nº:	<input style="width: 90%;" type="text"/>
External reference Nº:	<input style="width: 90%;" type="text"/>	Date:	<input style="width: 90%;" type="text"/>

<i>Charge Point Information</i>			
Model:	<input style="width: 90%;" type="text"/>	S/N:	<input style="width: 90%;" type="text"/>
Alias:	<input style="width: 90%;" type="text"/>	GPS:	<input style="width: 90%;" type="text"/>
Address:	<input style="width: 95%;" type="text"/>		
	<input style="width: 90%;" type="text"/>	Id:	<input style="width: 90%;" type="text"/>
<i>Body and Fastening</i>			
Nº	Description	Status	
1	Fastening verification		
2	Accuracy of the level calibration		
3	Blowing and hoovering of the inside		
4	Verification of rust and reparation of the affected zone		
5	Verification of the isolation rubbers		
6	External cleaning		
<i>Comments</i>			

Verification of the external electrical components				
Nº	Description	Status		
1	Verification of the external wires according to the product specifications			
2	Verification of the MCB and RCD protections according to the product specifications			
3		Neutral	Ground	Status
	Input Voltage check in Phase 1			
	Input Voltage check in Phase 2			
	Input Voltage check in Phase 3			
	Input Voltage check between Neutral and Ground			
Comments				

Verification of the internal electrical components				
Nº	Description	Status		
1	Verification of the internal wires and tightening of the terminals			
2	Isolation test and earth leakage			
3	MCB protection test			
4	Verification of the input and output voltage in power supplies			
5	Verification of the output voltage in the MCB			
Comments				

Configuration and Adjustments				
Nº	Description	Status		
1	Verification of the configuration of the network analysers			
2	Setup of the date/time and language			
3		Schuko	Type1	Type2
	Adjustment of the output power according to the maximum power supported by the supply connection			
4	Verification of the local network and 3G communications			
5	Firmware upgrade and application			
6	Verification of the internal communication between the devices			
7	Verification of OCPP y basic tests of functionality	Test		Result
		Comm. Backoffice		
		Start/Stop RFID		
		Start/Stop remote		
		White list		
Comments				

Functionality Test							
Nº	Description	Status					
		Schuko		Type 1		Type 2	
		LED	Display	LED	Display	LED	Display
1	Stand by						
	Charging						
	Ventilation						
	Pilot Signal						
	Ground						
	Door Alarm						
	2	Heater activation					
3	Ventilation activation						
4	Verification of the charge values						
Comments							

Preventive Maintenance Acceptance - Charge Point	
Client's Comments	
Sign and Acceptance	
In _____,	
Circontrol Staff	Client / Operator Charge Point

WEAR CHECK LIST POST EVOLVE SMART
DATE:

Charge Point Information

Model:		S/N:	
Alias of the unit:		Ticket N° Related:	
Installation Date:		Start Up Date:	
Wear check period (6/12 months):		Circontrol Staff:	
Client / Operator:			
Address:			

Charge Point Details

Nº	Description	Date	Status
1	Unit Updated Previously		<input type="checkbox"/> YES <input type="checkbox"/> NO
2	Unit Repaired Previously		<input type="checkbox"/> YES <input type="checkbox"/> NO
3	Limit Activated		<input type="checkbox"/> YES <input type="checkbox"/> NO
4	Power Load Management		<input type="checkbox"/> YES <input type="checkbox"/> NO
5	3G Communications Activated		<input type="checkbox"/> YES <input type="checkbox"/> NO
6	OCPD activated		<input type="checkbox"/> YES <input type="checkbox"/> NO

Comments**External General Inspection**

Nº	Description	Status
7	General Visual Inspection	<input type="checkbox"/> OK <input type="checkbox"/> NOK
8	Unit Under Cover	<input type="checkbox"/> OK <input type="checkbox"/> NOK
9	Minimum Front distance of the Installation (500mm)	<input type="checkbox"/> OK <input type="checkbox"/> NOK
10	Minimum Rear distance of the Installation (50mm)	<input type="checkbox"/> OK <input type="checkbox"/> NOK
11	Minimum Side distance of the Installation (500mm)	<input type="checkbox"/> OK <input type="checkbox"/> NOK

Comments

Body and Fastening			
Nº	Description	Status	
12	Exterior Paint	<input type="checkbox"/>	OK <input type="checkbox"/> NOK
13	Paint in areas of friction	<input type="checkbox"/>	OK <input type="checkbox"/> NOK
14	Bolt Fastening verification	<input type="checkbox"/>	OK <input type="checkbox"/> NOK
15	Accuracy of the level calibration	<input type="checkbox"/>	OK <input type="checkbox"/> NOK
16	Roof Cover Verification	<input type="checkbox"/>	OK <input type="checkbox"/> NOK
17	Blowing and hoovering of the inside	<input type="checkbox"/>	OK <input type="checkbox"/> NOK
18	Verification of the isolation rubbers	<input type="checkbox"/>	OK <input type="checkbox"/> NOK
Comments			

External Components			
Nº	Description	Status	
19	Type 2 Socket Housing (External inspection)	<input type="checkbox"/>	OK <input type="checkbox"/> NOK
20	LCD	<input type="checkbox"/>	OK <input type="checkbox"/> NOK
21	Lockable Handle	<input type="checkbox"/>	OK <input type="checkbox"/> NOK
22	LED Beacons	<input type="checkbox"/>	OK <input type="checkbox"/> NOK
Comments			

Verification of The Internal Components			
Nº	Description	Status	
23	Type 2 Socket Housing (Internal Inspection)	<input type="checkbox"/>	OK <input type="checkbox"/> NOK
24	LED Beacons	<input type="checkbox"/>	OK <input type="checkbox"/> NOK
25	Check Condensation on Components	<input type="checkbox"/>	OK <input type="checkbox"/> NOK
Comments			

Verification of Installation Electrical components			
	Description		Status
26	Verification of the external wires according to the product specifications		<input type="checkbox"/> OK <input type="checkbox"/> NOK
27	Verification of the MCB and RCD protections according to the product specifications (AC Circuit)		<input type="checkbox"/> OK <input type="checkbox"/> NOK
28		Neutra I	
		Input Voltage check in Phase 1	<input type="checkbox"/> OK <input type="checkbox"/> NOK
		Input Voltage check in Phase 2	<input type="checkbox"/> OK <input type="checkbox"/> NOK
		Input Voltage check in Phase 3	<input type="checkbox"/> OK <input type="checkbox"/> NOK
		Input Voltage check between Neutral and Ground	<input type="checkbox"/> OK <input type="checkbox"/> NOK
Comments			

Verification of the internal electrical components			
Nº	Description		Status
29	Verification of the internal wires and tightening of the terminals		<input type="checkbox"/> OK <input type="checkbox"/> NOK
30	Isolation Test and earth leakage		<input type="checkbox"/> OK <input type="checkbox"/> NOK
31	Secondary MCB's and RCD's protection test		<input type="checkbox"/> OK <input type="checkbox"/> NOK
32	Verification of the output voltage in the MCB's		<input type="checkbox"/> OK <input type="checkbox"/> NOK
33	Power Supply Devices 12Vdc / 24Vdc		<input type="checkbox"/> OK <input type="checkbox"/> NOK
34	Multiconnectors of 12Vdc / 24Vdc / 230V / Ground		<input type="checkbox"/> OK <input type="checkbox"/> NOK
35	Boards Connectors		<input type="checkbox"/> OK <input type="checkbox"/> NOK
36	Heater		<input type="checkbox"/> OK <input type="checkbox"/> NOK
37	Tamper System		<input type="checkbox"/> OK <input type="checkbox"/> NOK
38	Contactors Status		<input type="checkbox"/> OK <input type="checkbox"/> NOK
39	Relays Status		<input type="checkbox"/> OK <input type="checkbox"/> NOK
Comments			

Configuration and Adjustments			
Nº	Description	Status	
40	Configuration of the network analysers	<input type="checkbox"/> OK	<input type="checkbox"/> NOK
41	Adjustment of the sensitivity of the RCD	<input type="checkbox"/> OK	<input type="checkbox"/> NOK
42	Configuration of Thermostats	<input type="checkbox"/> OK	<input type="checkbox"/> NOK
43	Setup of the date/time and language	<input type="checkbox"/> OK	<input type="checkbox"/> NOK
44	Adjustment of the output power according to the maximum power supported by the supply connection (Indicate value)	<input type="checkbox"/> OK	<input type="checkbox"/> NOK
45	Configuration of the local network and 3G communications	<input type="checkbox"/> OK	<input type="checkbox"/> NOK
46	Verification of the firmware and application	<input type="checkbox"/> OK	<input type="checkbox"/> NOK
47	Verification of the communication between the internal devices	<input type="checkbox"/> OK	<input type="checkbox"/> NOK
48	Setup of the OCPP and basic tests of functionality	Test	<input type="checkbox"/>
		Comm. Backoffice	<input type="checkbox"/> OK <input type="checkbox"/> NOK
		Start/Stop RFID	<input type="checkbox"/> OK <input type="checkbox"/> NOK
		Start/Stop remote	<input type="checkbox"/> OK <input type="checkbox"/> NOK
		White list	<input type="checkbox"/> OK <input type="checkbox"/> NOK
Comments			

Functionality Test			
Nº	Description	Status	
49	Stand by	<input type="checkbox"/> OK	<input type="checkbox"/> NOK
50	Charging	<input type="checkbox"/> OK	<input type="checkbox"/> NOK
51	Earth leakage verification	<input type="checkbox"/> OK	<input type="checkbox"/> NOK
52	Complete Charge (10')	<input type="checkbox"/> OK	<input type="checkbox"/> NOK
53	Heater activation	<input type="checkbox"/> OK	<input type="checkbox"/> NOK
54	Verification of the charge values	<input type="checkbox"/> OK	<input type="checkbox"/> NOK
58	Screen information	<input type="checkbox"/> OK	<input type="checkbox"/> NOK
Comments			

<i>Commissioning Acceptance - Charge Point</i>	
<i>Client's Comments</i>	
<i>Sign and Acceptance</i>	
In _____ ,	
Circontrol Staff	Customer / Operator of CP

14 TECHNICAL DATA

14.1 GENERAL

MECHANICAL	
Material	Aluminium & ABS
Enclosure Rating	IP54 /IK10
Working temperature	-10 to 45°C
Working temperature extended (optional)	-30 to 45°C
Working humidity	5% ... 95%
RFID System	ISO/IEC14443A/B
LCD Display	Multilanguage LCD
Rear Light beacon	Three colour LED status
Dimensions	450x 290 x1550 mm
Weight	55 kg
ELECTRICAL	
Power limit control	Mode 3 PWM duty (ISO/IEC 61851-1)
RFID reader	ISO / IEC14443A / B MIFARE Classic/DESFire EV1 ISO 18092 / ECMA-340 NFC 13.56MHz
RFID Legic reader (optional)	LEGIC Advant LEGIC Prime ISO14443 A+B compatible to part 4: MIFARE DESFireEV13), MIFARE Plus S, X3), MIFARE Pro X3), MIFARE SmartMX3), SLE66Rxx (my-d move)3), SLE44R351), PayPass1), NTAG2xx4), ISO15693:EM4x353), Tag-It3), SRF55Vxx (my-d vicinity)3), ICODE SLI3) MIFARE: Classic3), Classic EV14), Mini1), Ultralight3), Ultralight C3), UltralightEV14) Sony FeliCa1) NFC Forum Tag Type 2-43) PicoPass1), HID iCLASS1), HID iCLASS SE/SR1)
Power output management	Embedded load management
RCD	RCD type A – RCD type B (optional)
Surge protection (optional)	Surge protection IEC 61643-1 (class II)
Socket / Cable (optional)	Socket type 2 Cable type 2 Cable type 1 (single-phase models only) CEE 7/3
NETWORK CONNECTION	
Ethernet	10/100BaseTX
Mobile Communications (optional)	4G/3G/GPRS/GSM
Interface protocol (optional)	OCPP 1.2 / 1.5 SOAP / 1.6 JSON

14.2 MODEL T

INPUT			
Input voltage		400VAC Three-phase	
Nominal input current		64A	
Nominal input power		44kW	
Input frequency		50/60Hz	
OUTPUTS		PLUG A	PLUG B
Rated output current		32A	32A
Rated output		22kW	22kW
Output AC voltage		400VAC Three-phase	
CHARGE SYSTEM		PLUG A	PLUG B
		Mode 3 (IEC 61851)	Mode 3 (IEC 61851)
PROTECTIONS		PLUG A	PLUG B
MCB	Curve C	40A	40A
RCD	Type A	30mA	30mA
SOCKET OUTLETS			
2 x Type 2 (UNE EN 62196-1) lock system			

14.3 MODEL S

INPUT			
Input voltage		230VAC Single-phase	
Nominal input current		64A	
Nominal input power		14,8kW	
Input frequency		50/60Hz	
OUTPUTS		PLUG A	PLUG B
Rated output current		32A	32A
Rated output		7,4kW	7,4kW
Output AC voltage		230VAC Single-phase	
CHARGE SYSTEM		PLUG A	PLUG B
		Mode 3 (IEC 61851)	Mode 3 (IEC 61851)
PROTECTIONS		PLUG A	PLUG B
MCB	Curve C	40A	40A
RCD	Type A	30mA	30mA
SOCKET OUTLETS			
2 x Type 2 (UNE EN 62196-1) lock system			

14.4 MODEL SS

INPUT			
Input voltage		230VAC Single-phase	
Nominal input current		32A	
Nominal input power		7,4kW	
Input frequency		50/60Hz	
OUTPUTS		PLUG A	PLUG B
Rated output current		16A	16A
Rated output		3,6kW	3,6kW
Output AC voltage		230VAC Single-phase	
CHARGE SYSTEM		PLUG A	PLUG B
		Mode 1 (IEC 61851)	Mode 1 (IEC 61851)
PROTECTIONS		PLUG A	PLUG B
MCB	Curve C	16A	16A
RCD	Type A	30mA	30mA
SOCKET OUTLETS			
2 x CEE 7/3			

14.5 MODEL TM

INPUT			
Input voltage		400VAC Three-phase	
Nominal input current		48A	
Nominal input power		25.7kW	
Input frequency		50/60Hz	
OUTPUTS		PLUG A	PLUG B
Rated output current		32A	16A
Rated output		22kW	3.7kW
Output AC voltage		400VAC Three-phase	230VAC Single-phase
CHARGE SYSTEM		PLUG A	PLUG B
		Mode 3 (IEC 61851)	Mode 1 (IEC 61851)
PROTECTIONS		PLUG A	PLUG B
MCB	Curve C	40A	40A
RCD	Type A	30mA	30mA
SOCKET OUTLETS			
1 x Type 2 (UNE EN 62196-1) lock system & 1 x CEE 7/3			

14.6 MODEL T-one

INPUT		
Input voltage	400VAC Three-phase	
Nominal input current	32A	
Nominal input power	22kW	
Input frequency	50/60Hz	
OUTPUTS		PLUG A
Rated output current	32A	
Rated output	22kW	
Output AC voltage	400VAC Three-phase	
CHARGE SYSTEM		PLUG A
		Mode 3 (IEC 61851)
PROTECTIONS		PLUG A
MCB	Curve C	40A
RCD	Type A	30mA
SOCKET OUTLET		
1 x Type 2 (UNE EN 62196-1) lock system		

14.7 MODEL C63

INPUT			
Input voltage	400VAC Three-phase		
Nominal input current	126A		
Nominal input power	88kW		
Input frequency	50/60Hz		
OUTPUTS		PLUG A	PLUG B
Rated output current	63A		63A
Rated output	44kW		44kW
Output AC voltage	400VAC Three-phase		
CHARGE SYSTEM		PLUG A	PLUG B
		Mode 3 (IEC 61851)	Mode 3 (IEC 61851)
PROTECTIONS		PLUG A	PLUG B
MCB	Curve C	80A	80A
RCD	Type A	30mA	30mA
SOCKET OUTLETS			
2 x Cable Type 2 (mandatory, UNE EN 62196-1)			

14.8 MODEL C63-one

INPUT		
Input voltage	400VAC Three-phase	
Nominal input current	63A	
Nominal input power	44kW	
Input frequency	50/60Hz	
OUTPUTS		PLUG A
Rated output current	63A	
Rated output	44kW	
Output AC voltage	400VAC Three-phase	
CHARGE SYSTEM		PLUG A
	Mode 3 (IEC 61851)	
PROTECTIONS		PLUG A
MCB	Curve C	80A
RCD	Type A	30mA
SOCKET OUTLET		
1 x Cable Type 2 (mandatory, UNE EN 62196-1)		

14.9 MODEL TM4

INPUT				
Input voltage	400VAC Three-phase			
Nominal input current	64A			
Nominal input power	44kW			
Input frequency	50/60Hz			
OUTPUTS	PLUG A		PLUG B	
	TYPE 2	CEE 7/3	TYPE 2	CEE 7/3
Rated output current	32A	16A	32A	16A
Rated output	22kW	3,6kW	22kW	3,6kW
Output AC voltage	400VAC Three- phase	230VAC Single- phase	400VAC Three- phase	230VAC Single- phase
CHARGE SYSTEM	PLUG A		PLUG B	
TYPE 2	Mode 3 (IEC 61851)		Mode 3 (IEC 61851)	
CEE 7/3	Mode 1 (IEC 61851)		Mode 1 (IEC 61851)	
PROTECTIONS	PLUG A		PLUG B	
OUTPUT TYPE 2				
MCB	Type A	40A	40A	
RCD	Curve C	30mA	30mA	
OUTPUT CEE 7/3				
MCB	Type A	16A	16A	
SOCKET OUTLETS				
2 x Type 2 + 2 x CEE 7/3				

15 WIRING DIAGRAMS PHASE II

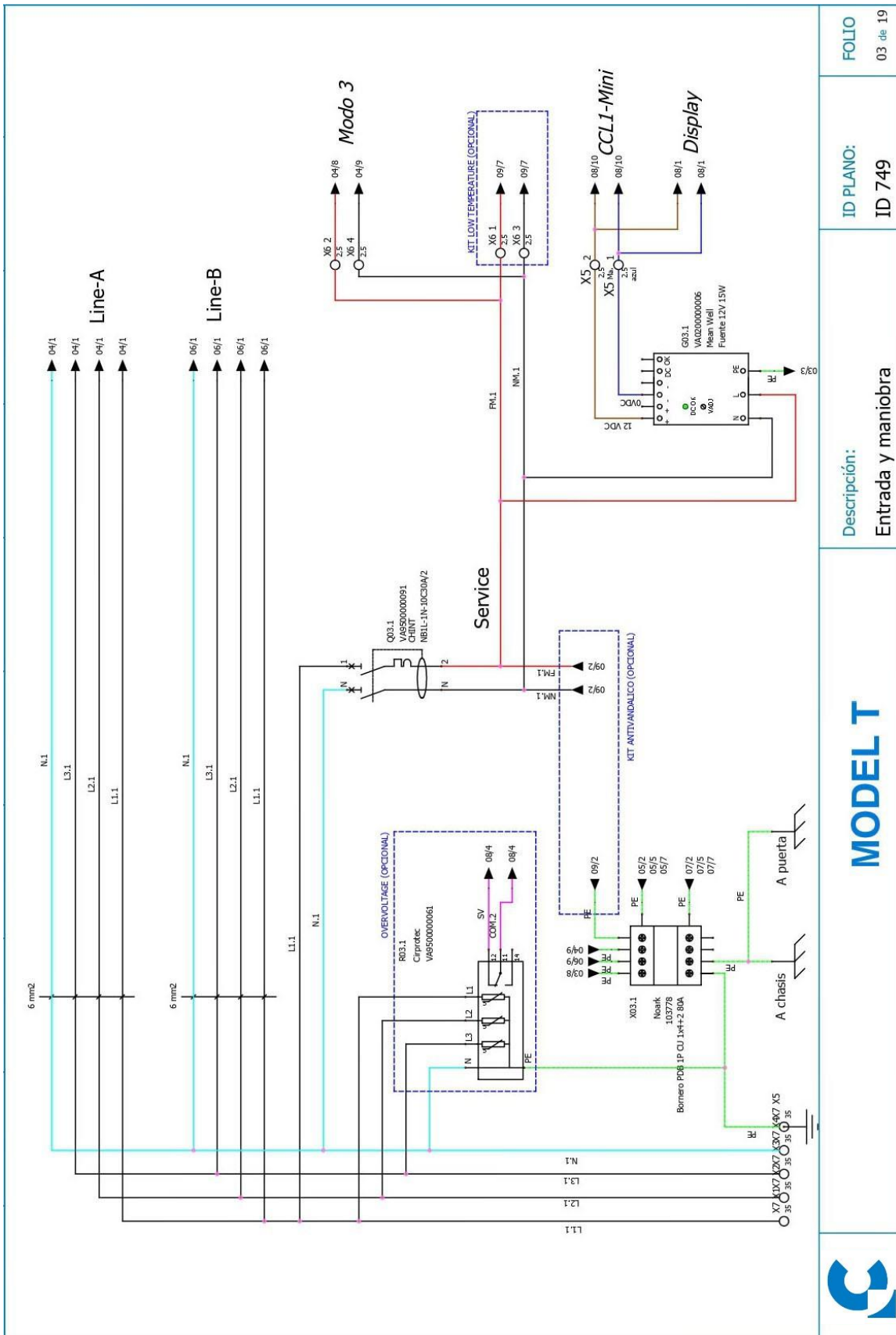

FOLIO
03 de 19

ID PLANO:
ID 749

Descripción:
Entrada y maniobra

MODEL T



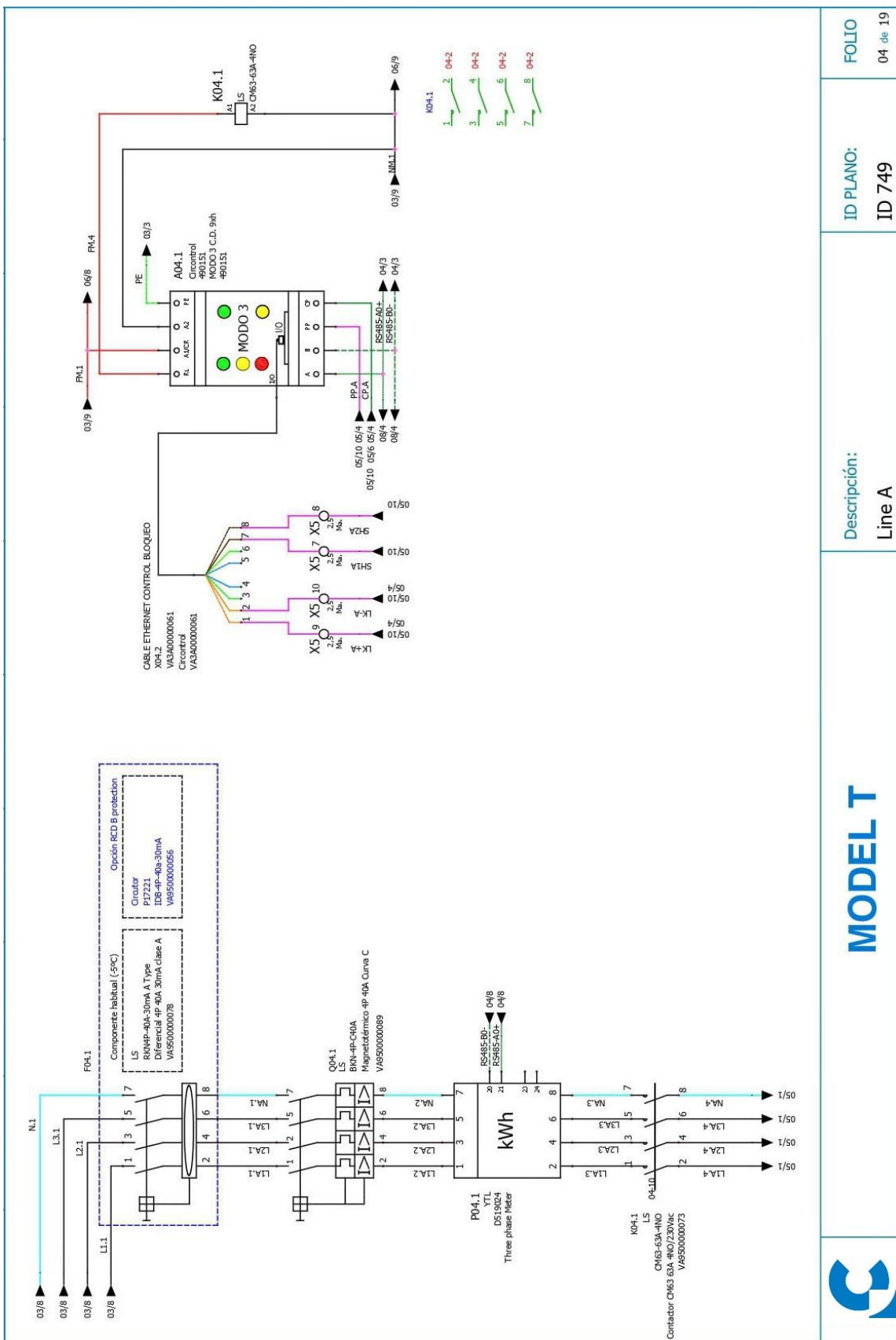

MODEL T

Descripción:
Line A

ID PLANO:
ID 749

FOLIO
04 de 19

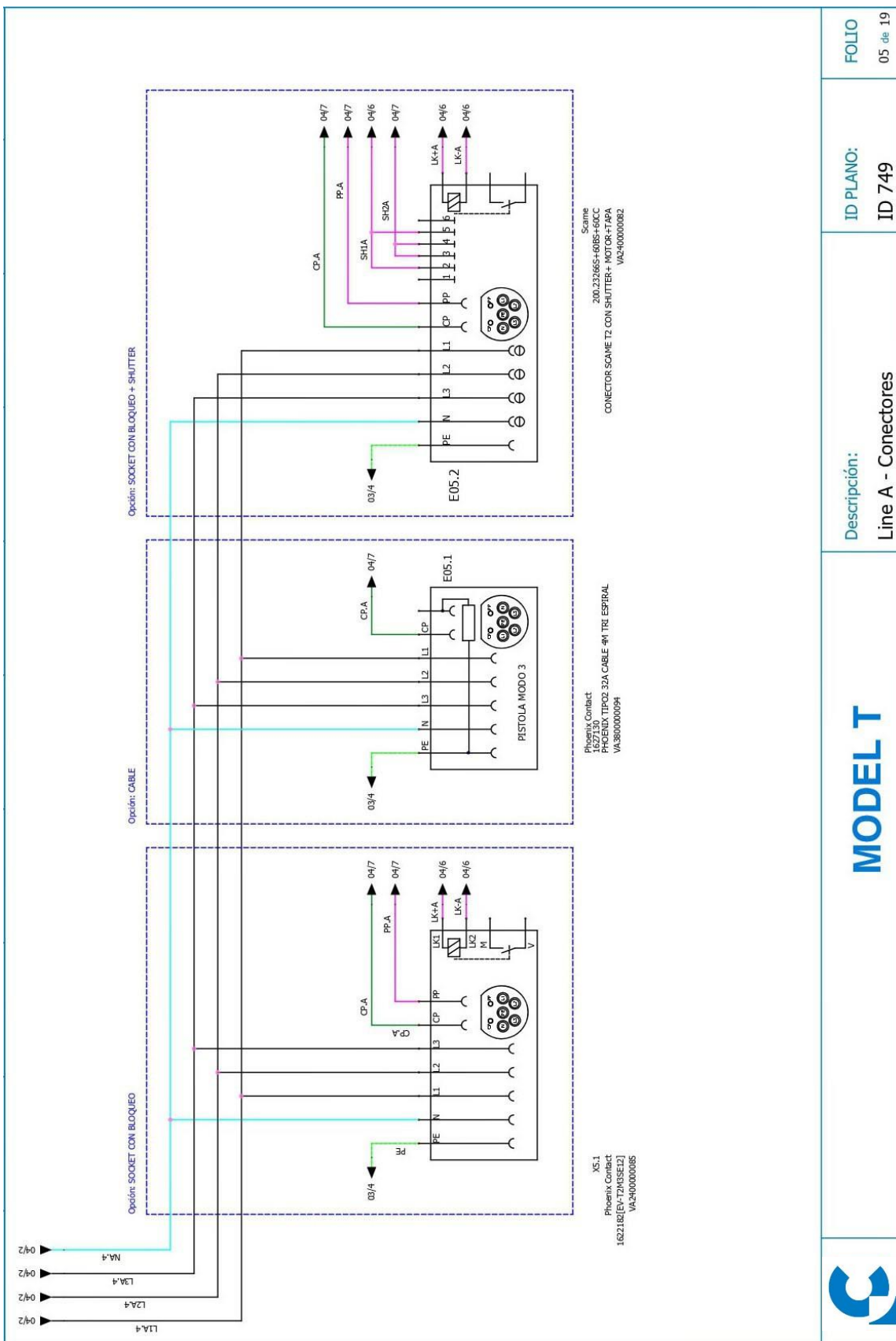

MODEL T

Descripción:
Line A - Conectores

ID PLANO:
ID 749

FOLIO
05 de 19

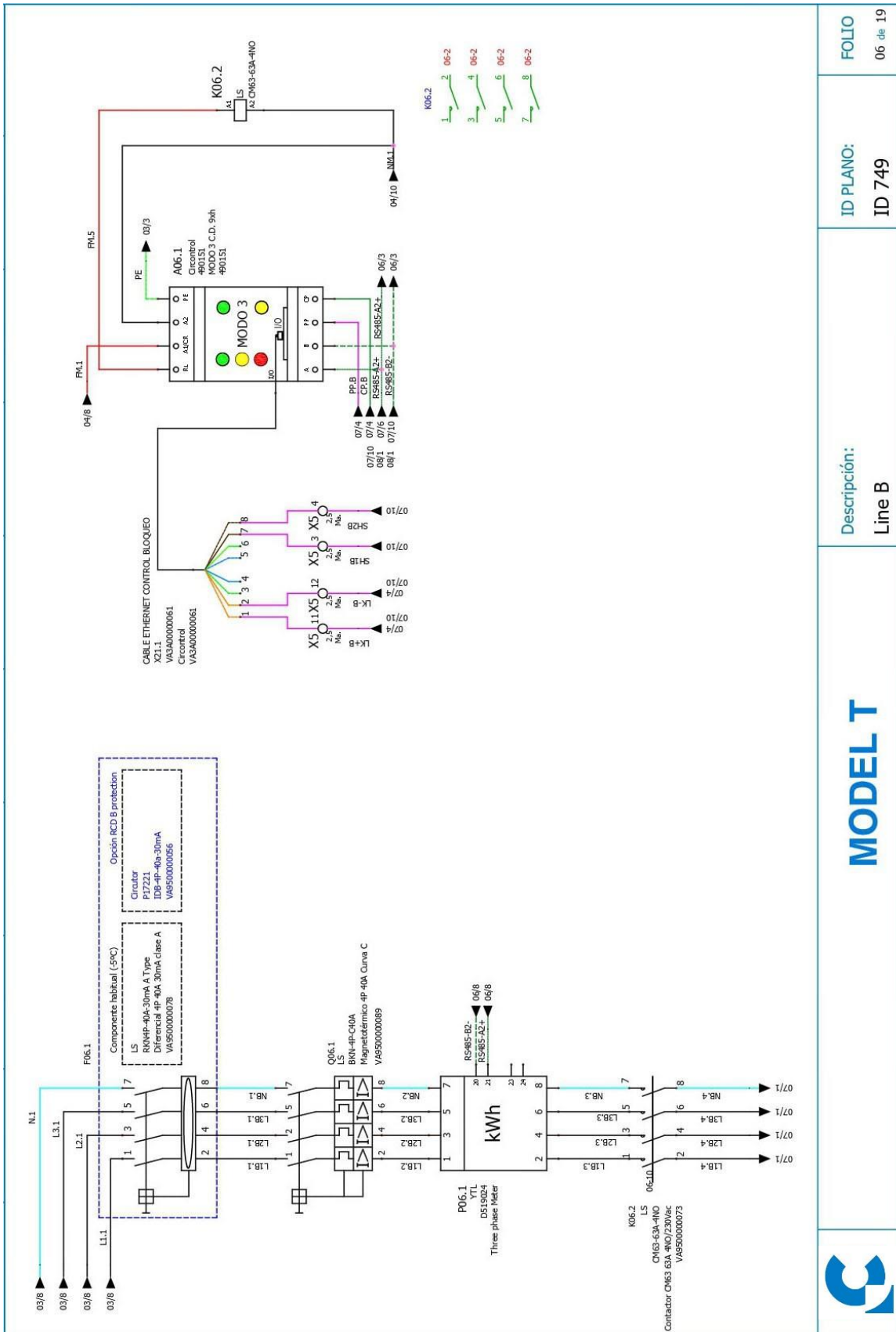

MODEL T

Descripción:
Line B

ID PLANO:
ID 749

FOLIO
06 de 19

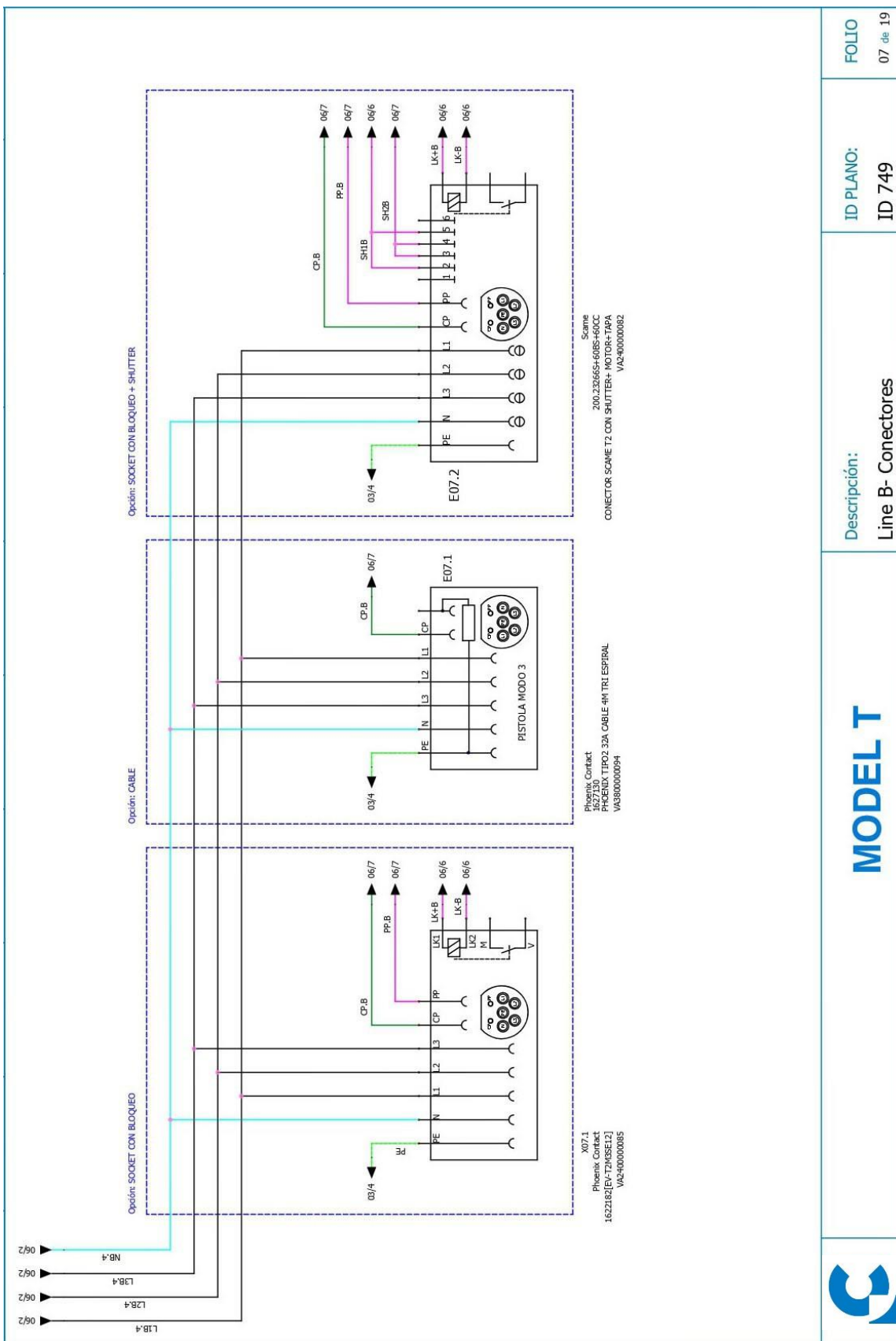

FOLIO
07 de 19

ID PLANO:
ID 749

Descripción:
Line B- Conectores

MODEL T



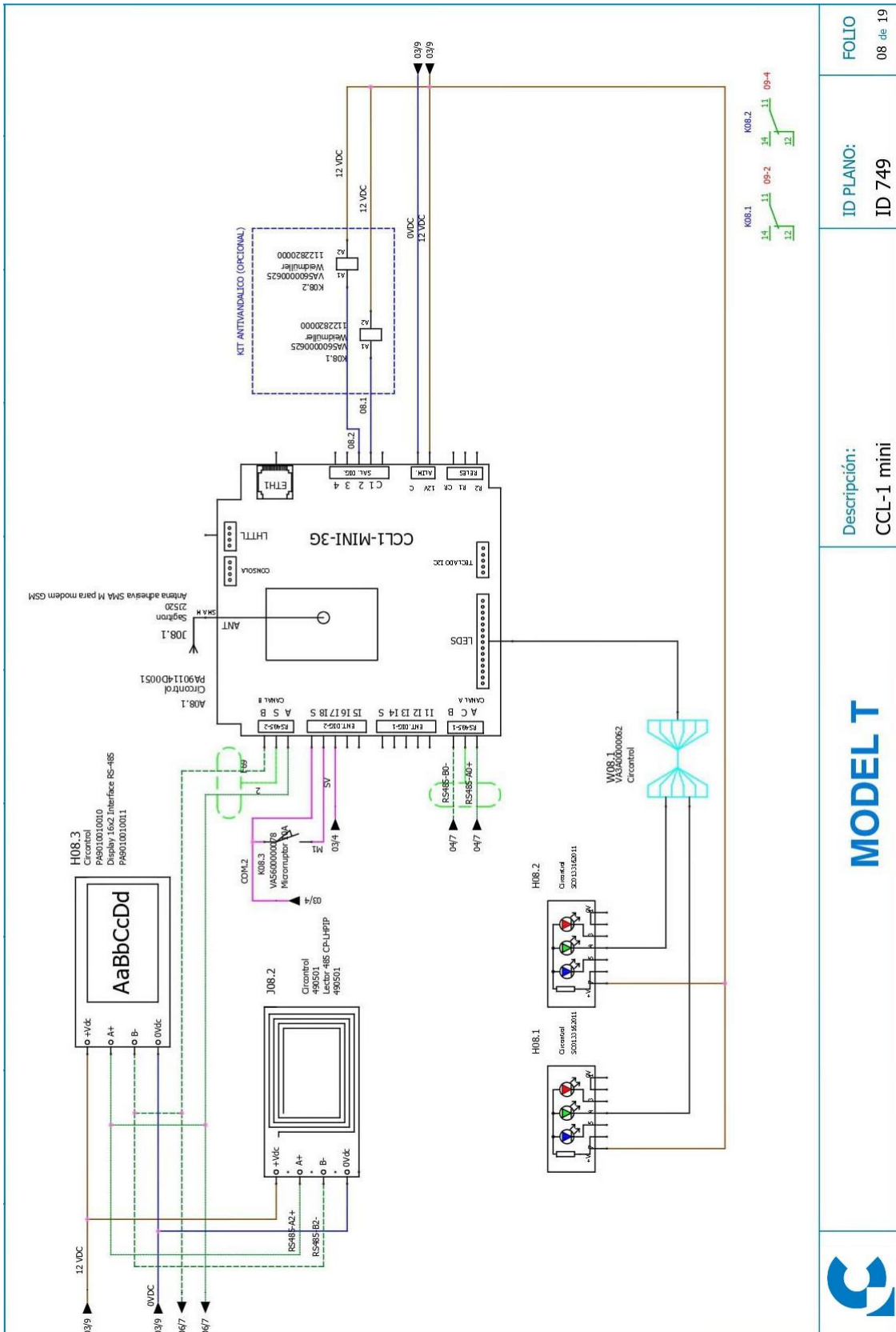

FOLIO 08 de 19	ID PLANO: ID 749	Descripción: CCL-1 mini	<h1>MODEL T</h1>	
-------------------	---------------------	----------------------------	------------------	--

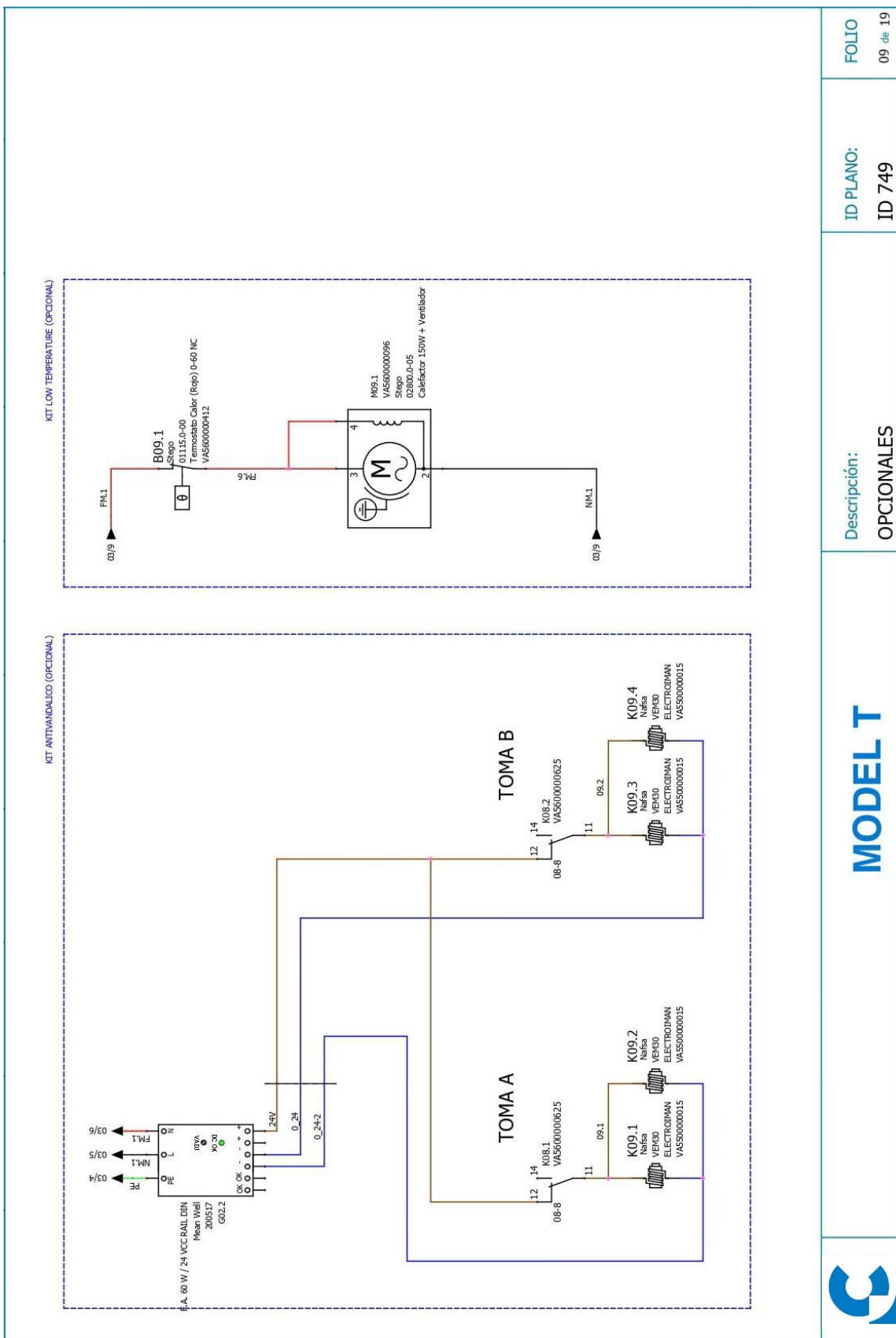

MODEL T

Descripción:
OPCIONALES

ID PLANO:
ID 749

FOLIO
09 de 19



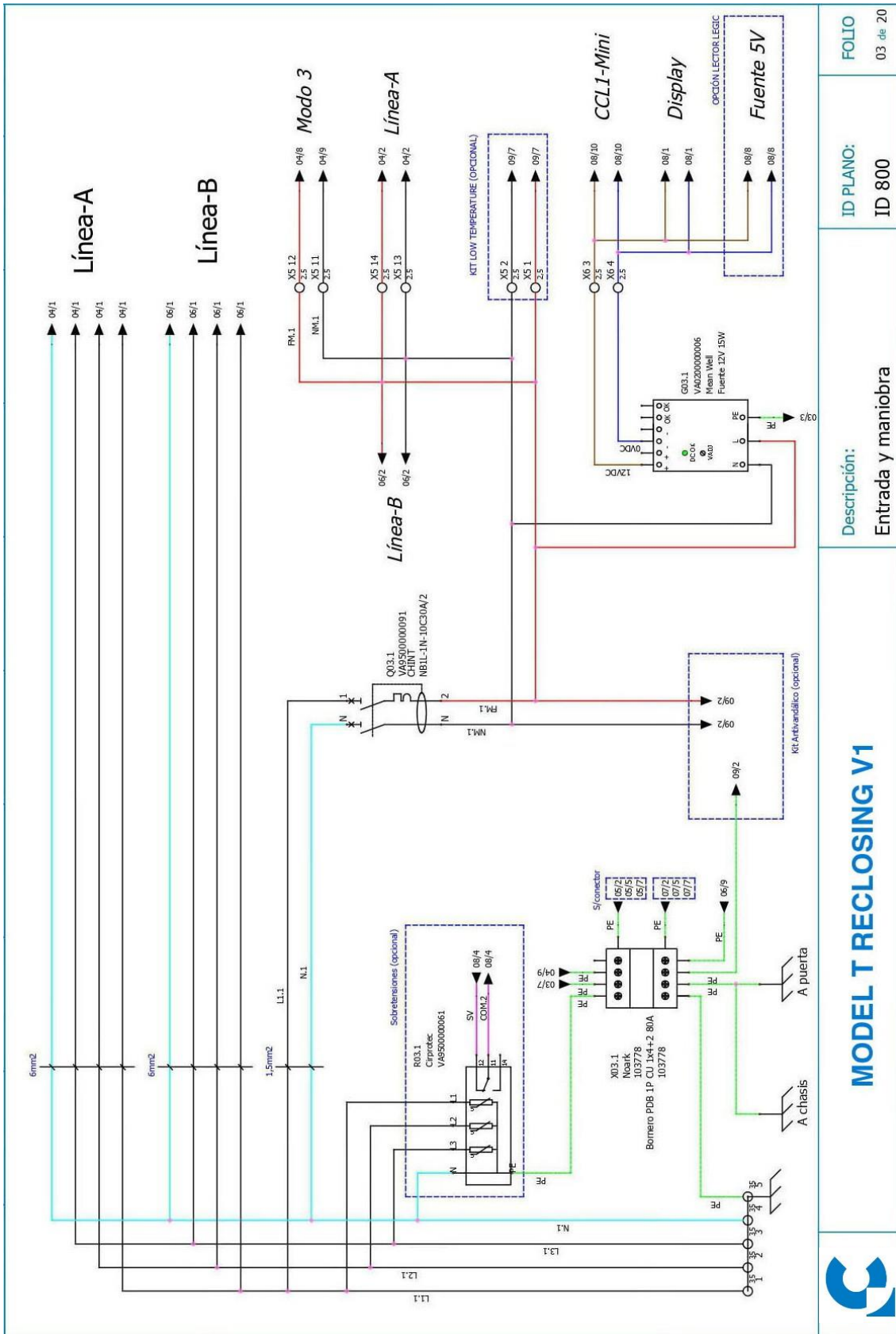

FOLIO 03 de 20
ID PLANO: ID 800
Descripción: Entrada y maniobra
MODEL T RECLOSING V1

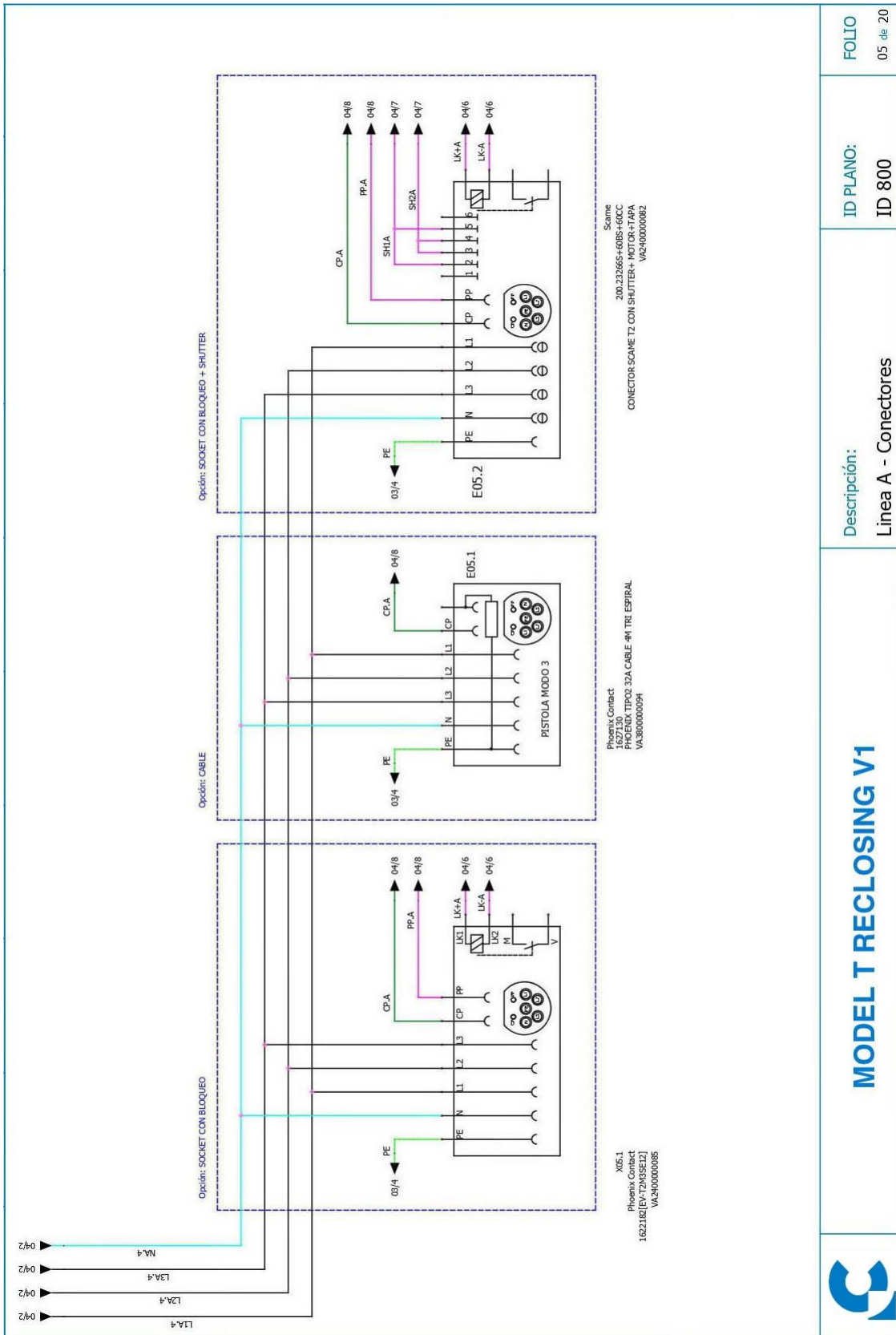

MODEL T RECLOSING V1

Descripción:
Linea A - Conectores

ID PLANO:
ID 800

FOLIO
 05 de 20

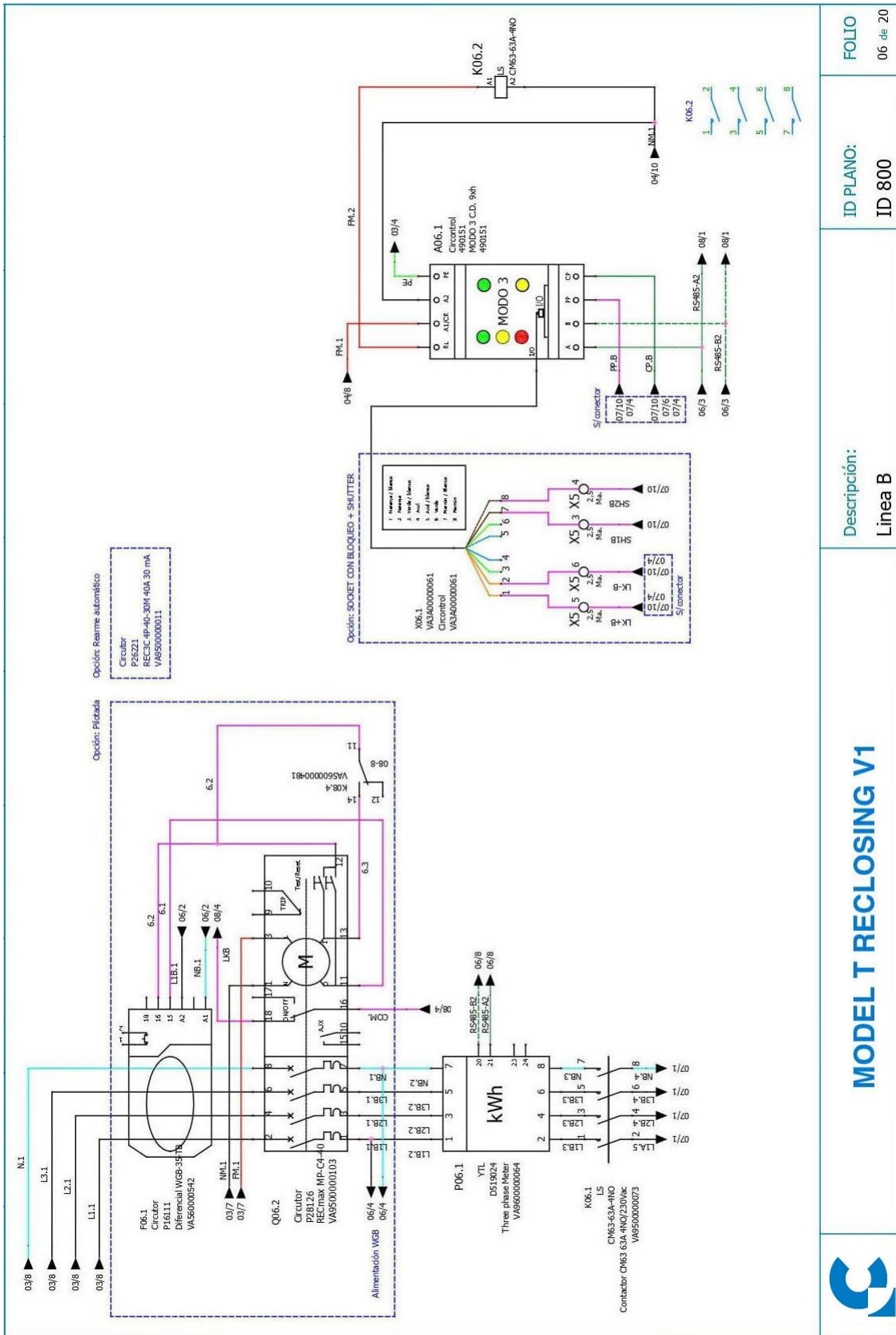

FOLIO 06 de 20

ID PLANO: ID 800

Descripción: Línea B

MODEL T RECLOSING V1

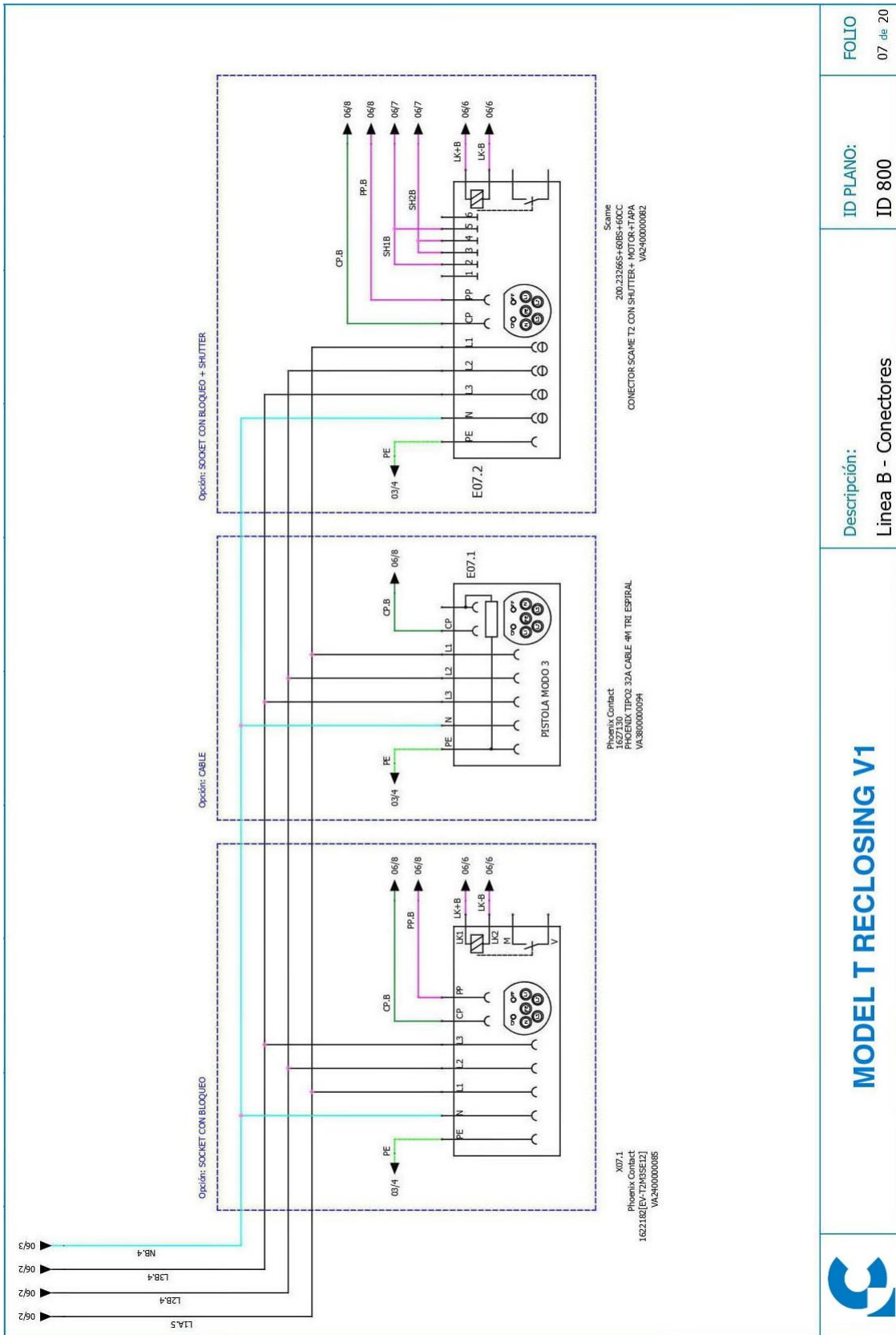

	MODEL T RECLOSING V1	Descripción: Linea B - Conectores	ID PLANO: ID 800	FOLIO 07 de 20
--	-----------------------------	--------------------------------------	---------------------	-------------------

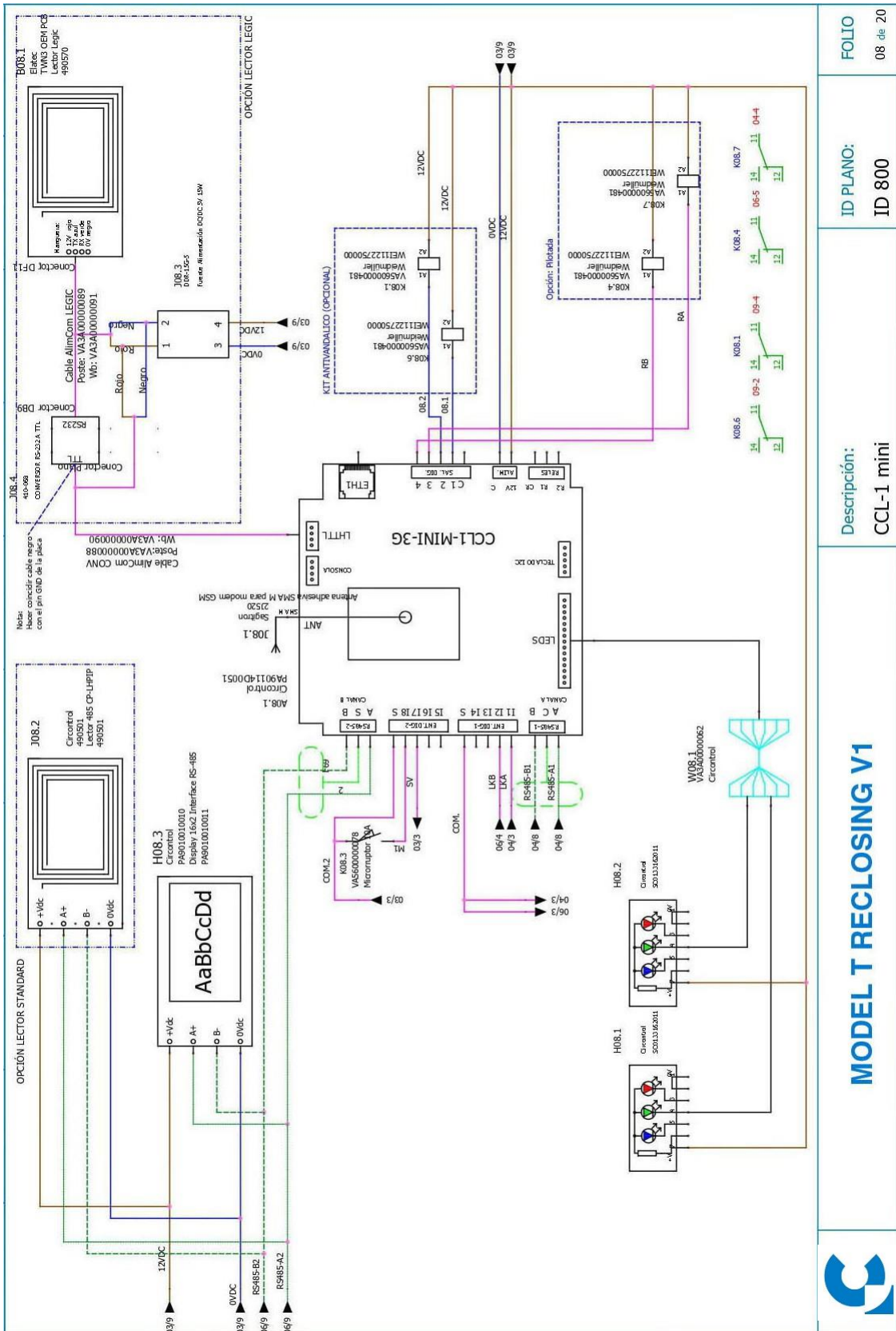

FOLIO
08 de 20

ID PLANO:
ID 800

Descripción:
CCL-1 mini

MODEL T RECLOSING V1



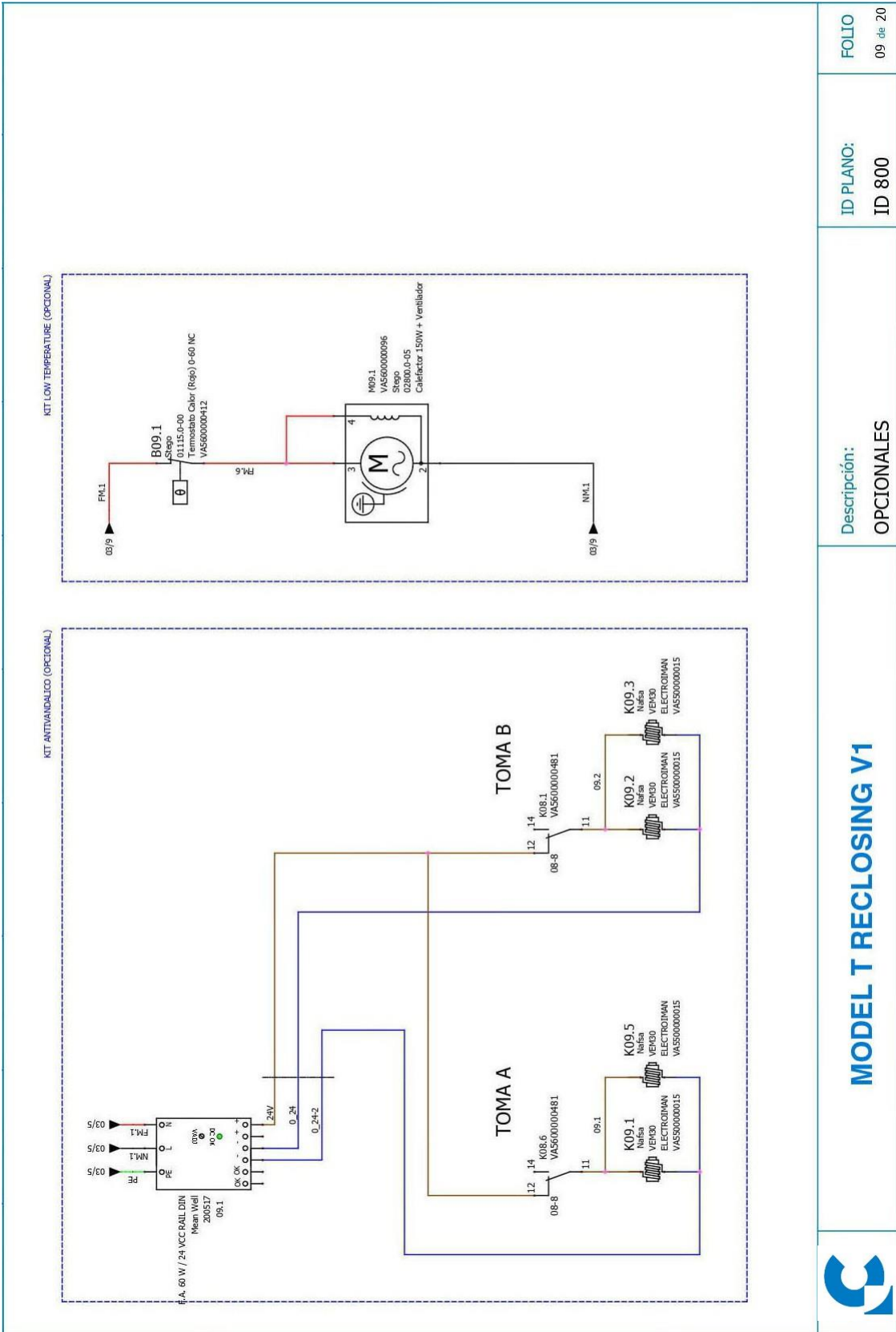

MODEL T RECLOSING V1

Descripción:
OPCIONALES

ID PLANO:
ID 800

FOLIO
09 de 20

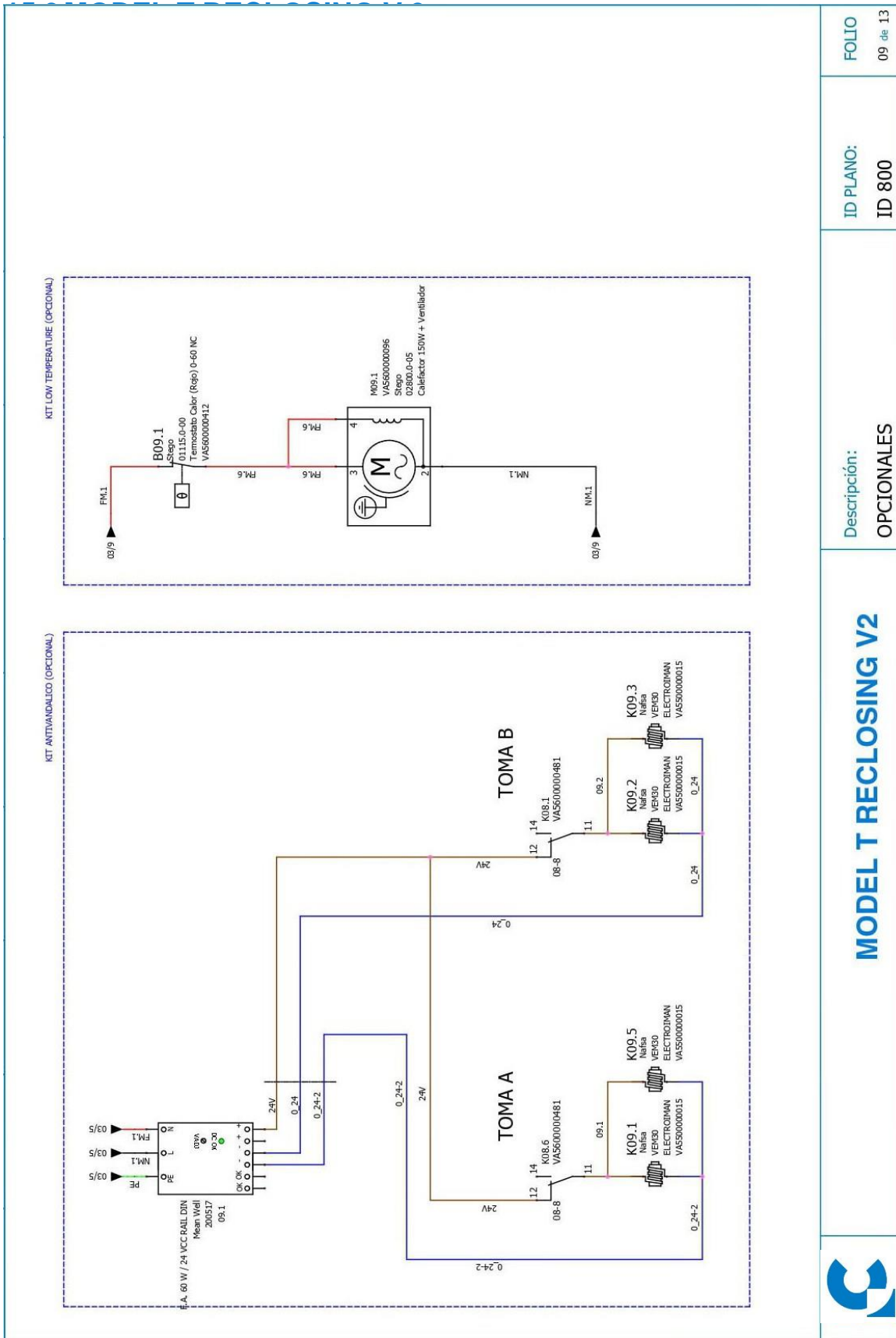

FOLIO
09 de 13

ID PLANO:
ID 800

Descripción:
OPCIONALES

MODEL T RECLOSING V2



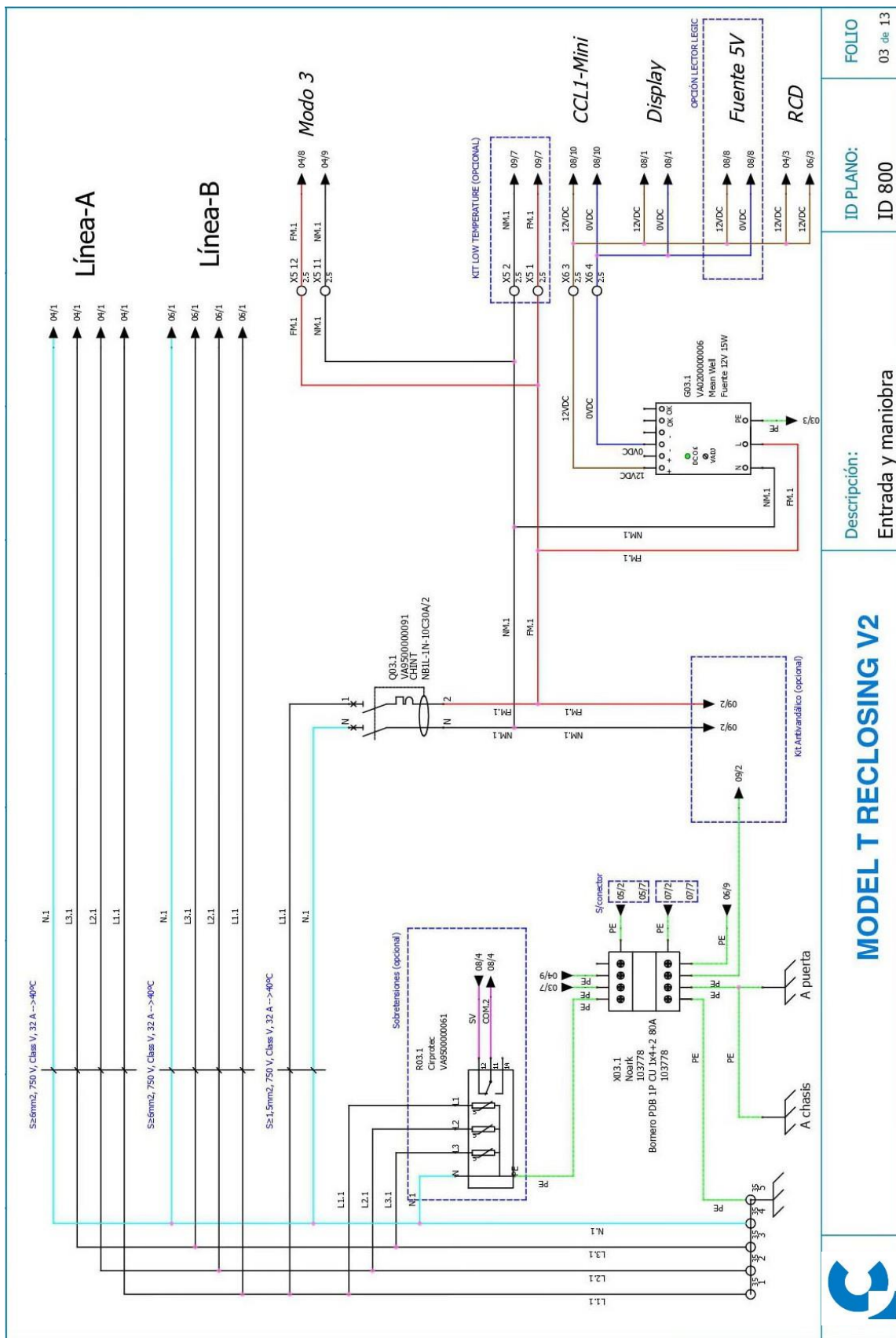

FOLIO
03 de 13

ID PLANO:
ID 800

Descripción:
Entrada y maniobra

MODELT RECLOSING V2

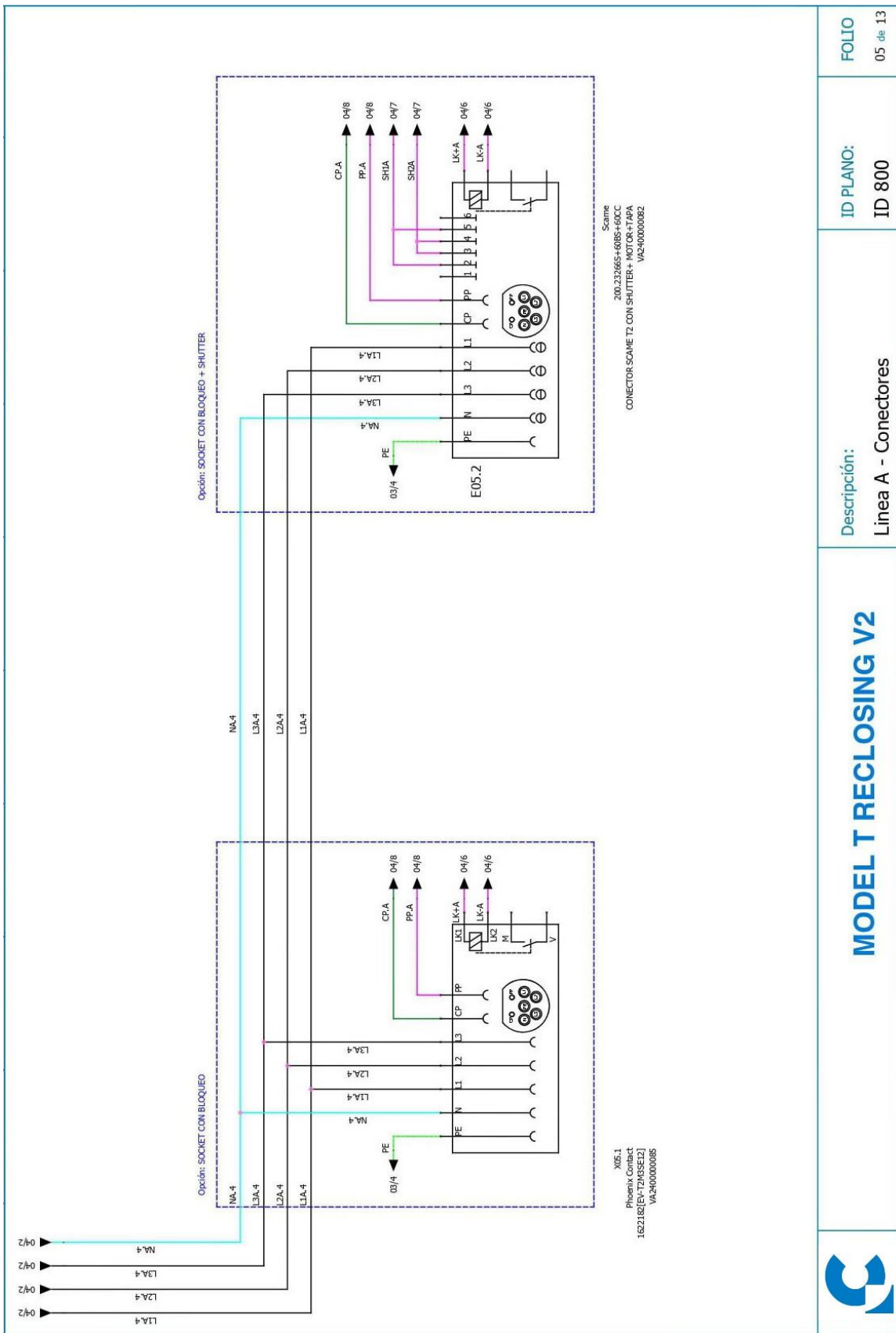

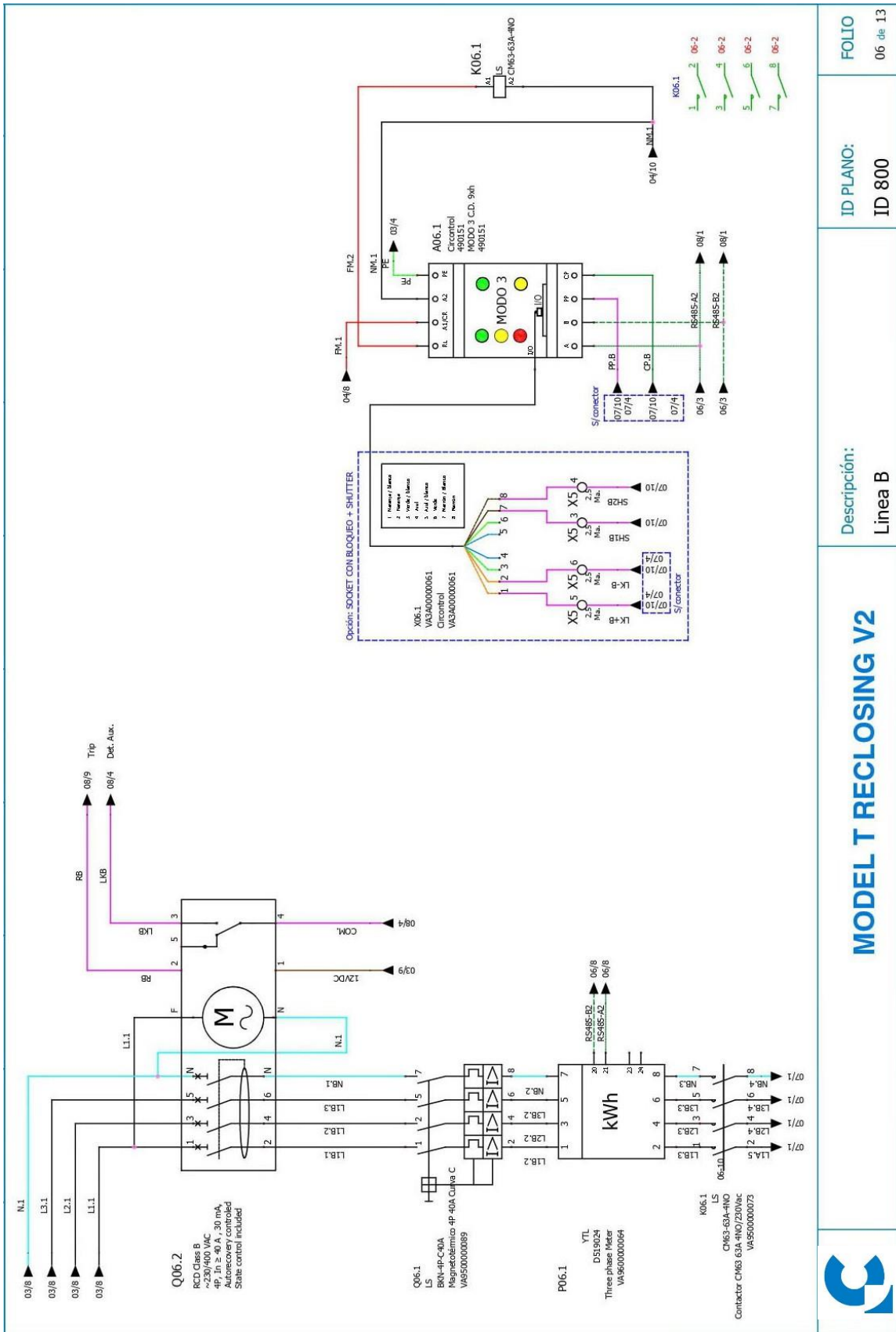

FOLIO
06 de 13

ID PLANO:
ID 800

Descripción:
Linea B

MODEL T RECLOSING V2



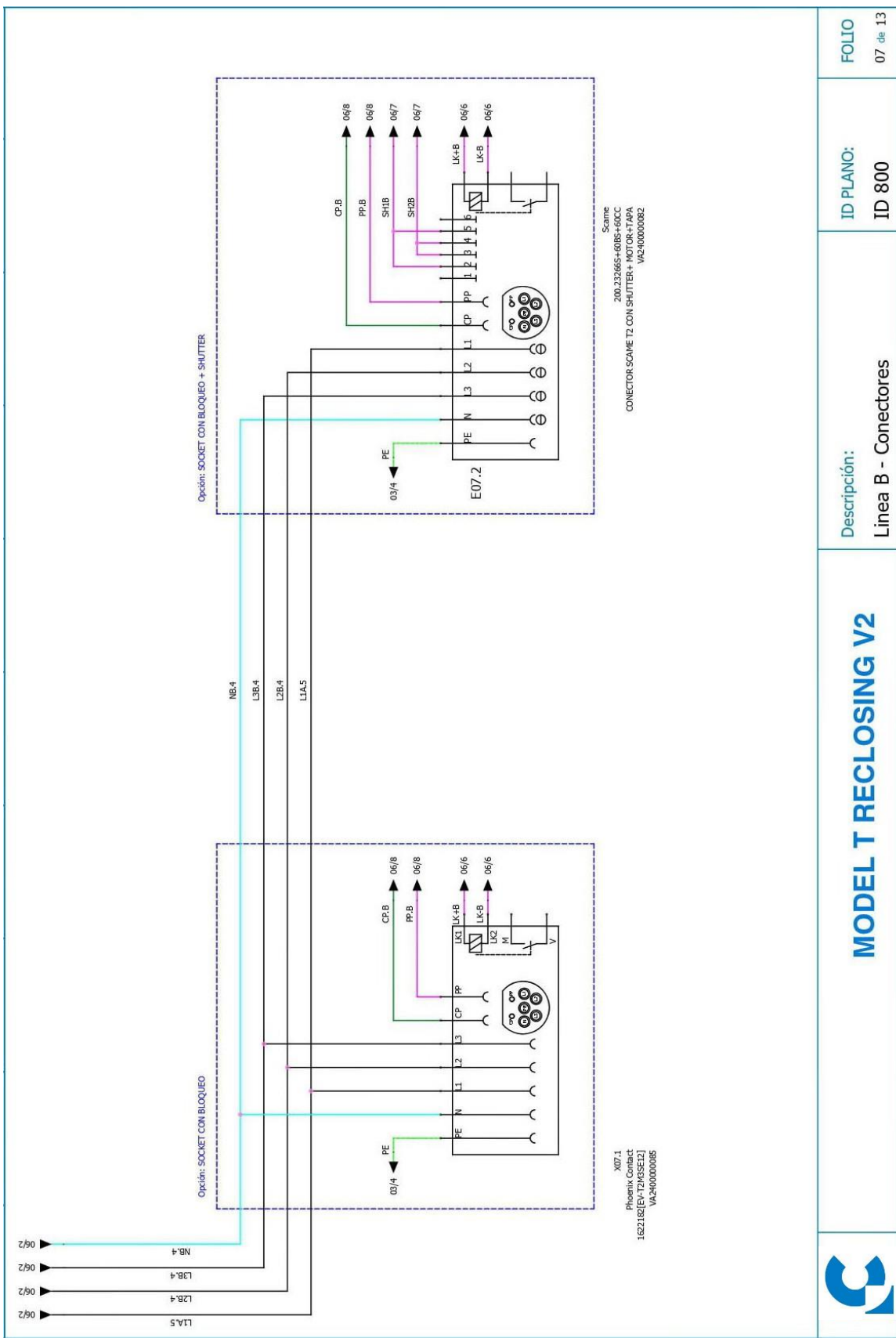

MODEL T RECLOSING V2

Descripción:
 Línea B - Conectores

ID PLANO:
 ID 800

FOLIO
 07 de 13

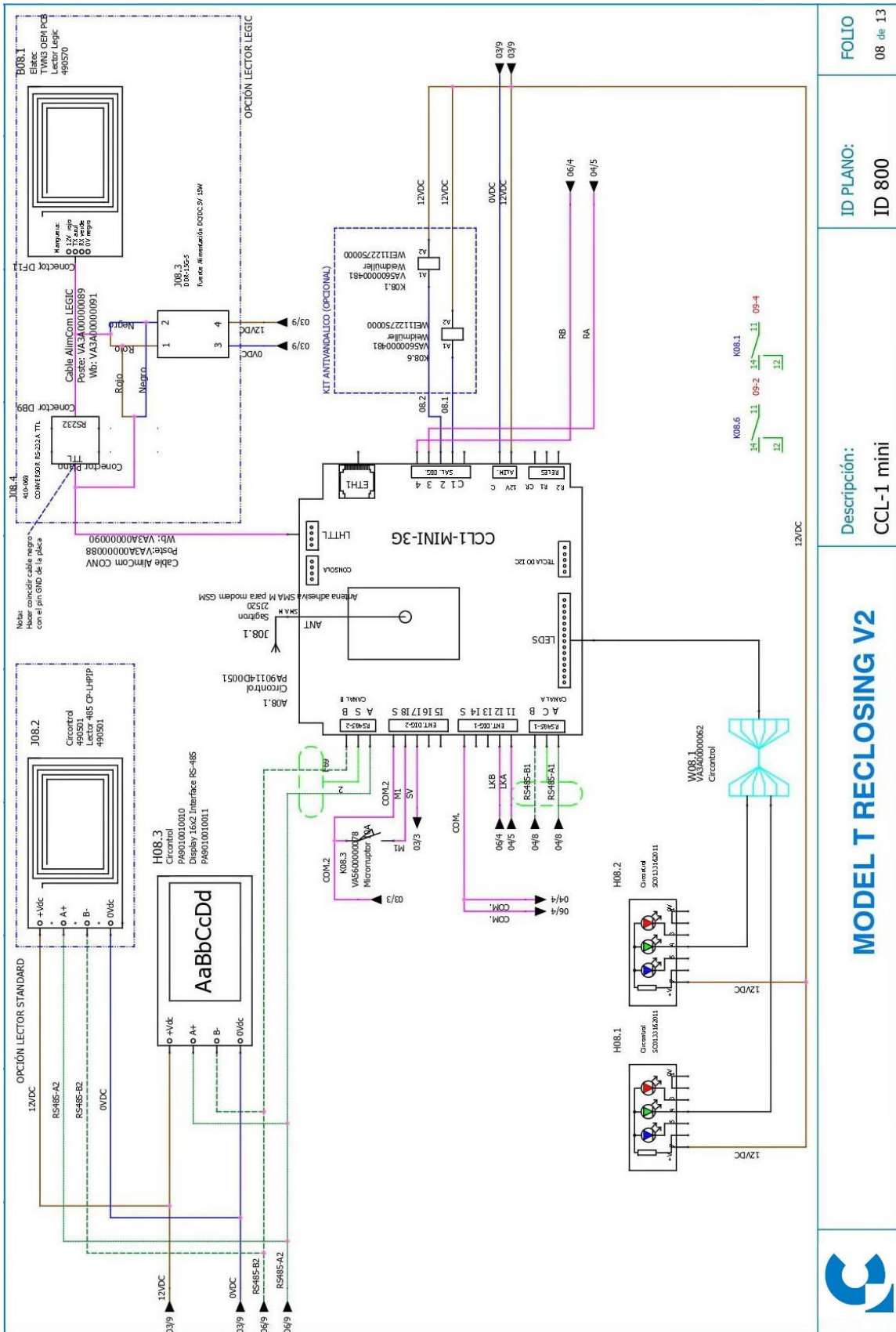

FOLIO
08 de 13

ID PLANO:
ID 800

Descripción:
CCL-1 mini

MODEL T RECLOSING V2



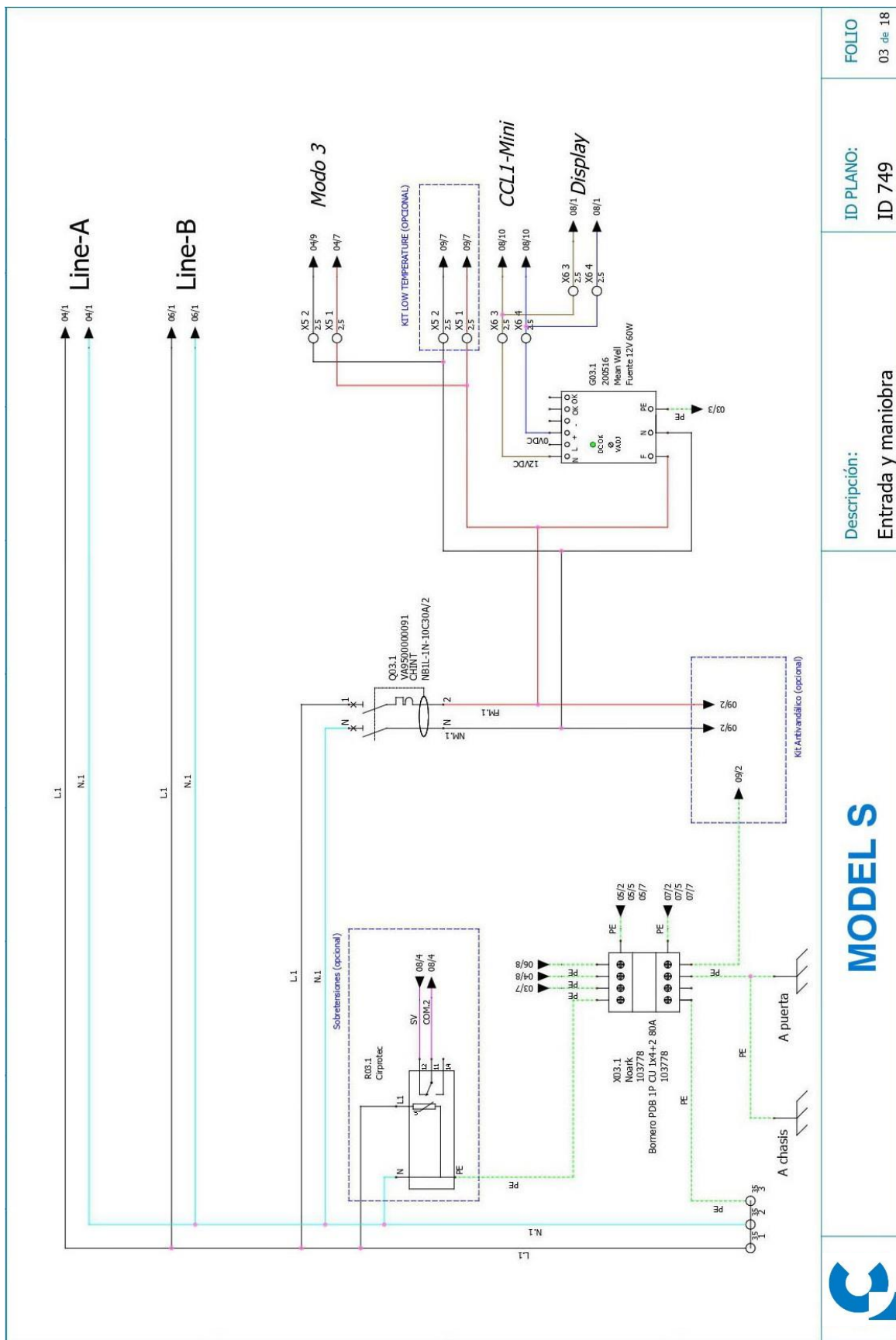

MODELS

Descripción:
Entrada y maniobra

ID PLANO:
ID 749

FOLIO
 03 de 18

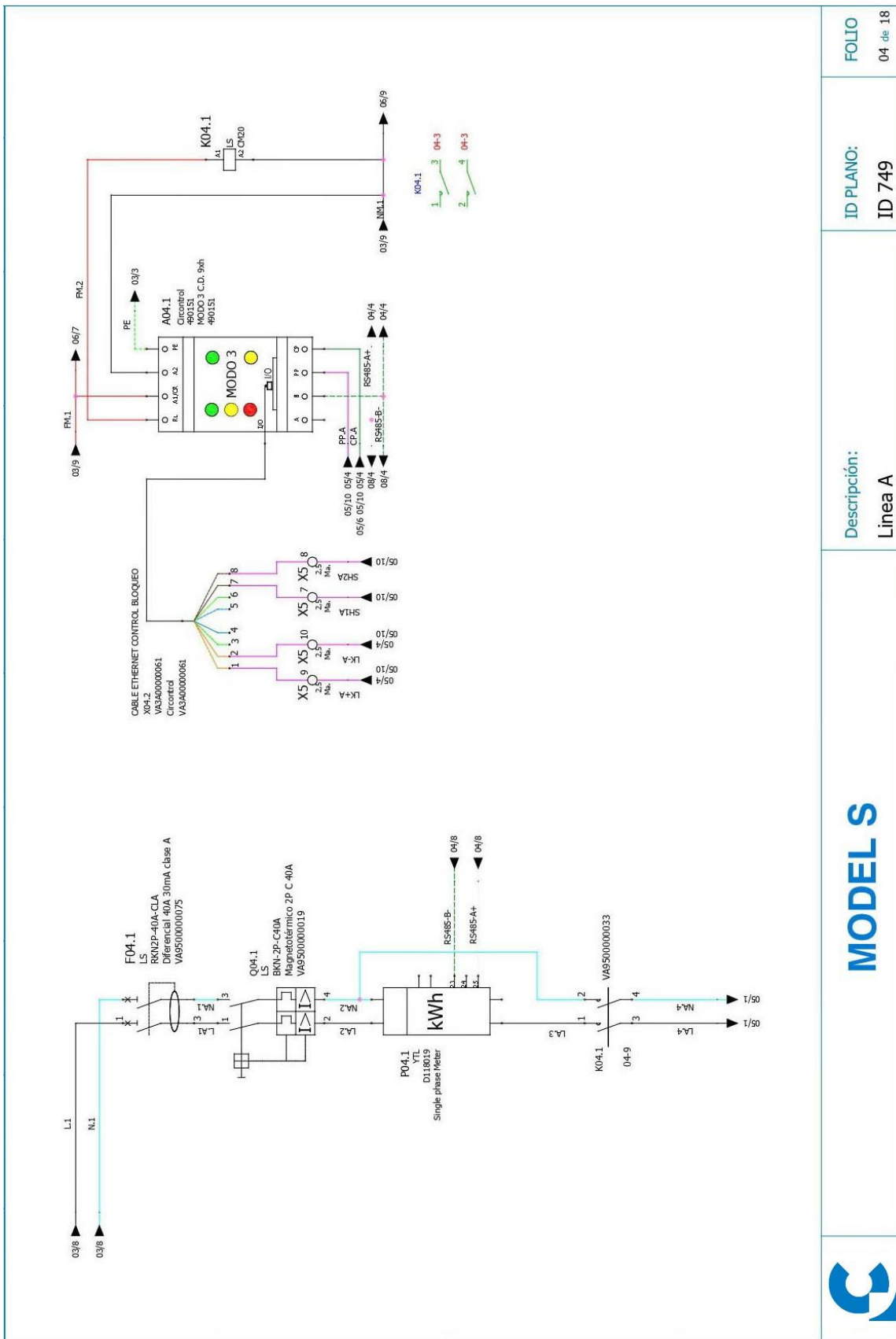

MODELS

Descripción:
 Línea A

ID PLANO:
 ID 749

FOLIO
 04 de 18

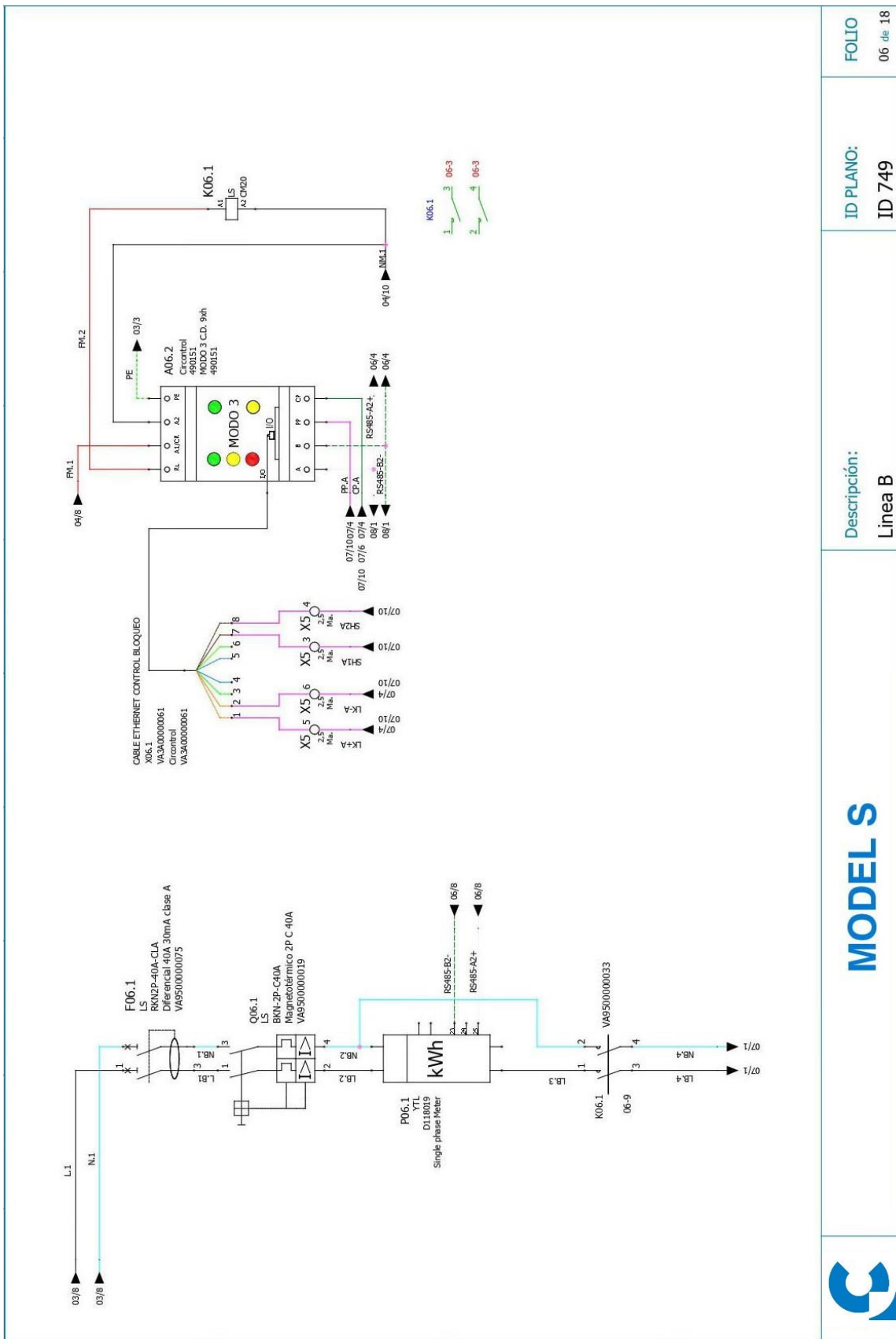

MODELS

Descripción:
 Línea B

ID PLANO:
 ID 749

FOLIO
 06 de 18

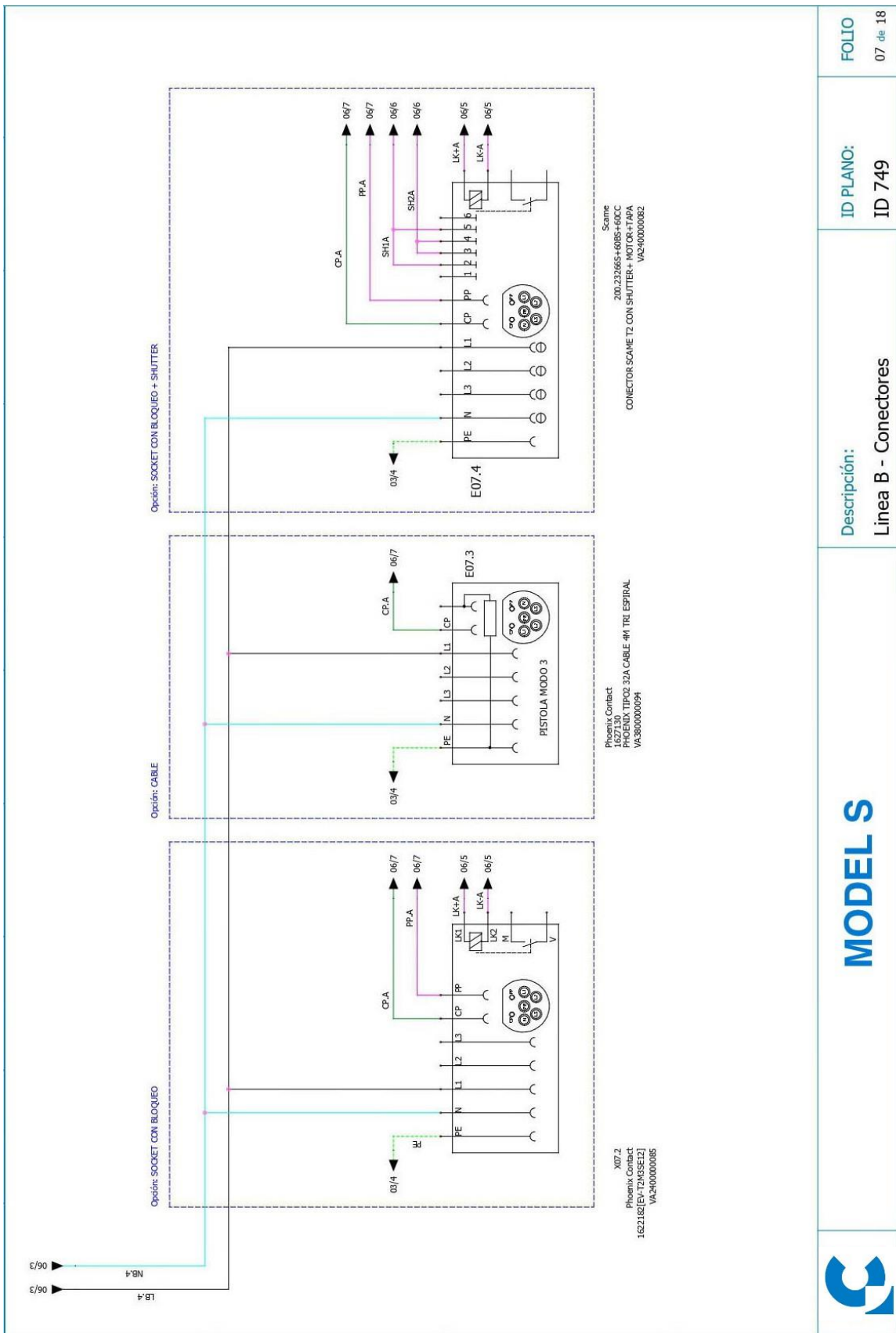

FOLIO
07 de 18

ID PLANO:
ID 749

Descripción:
Linea B - Conectores



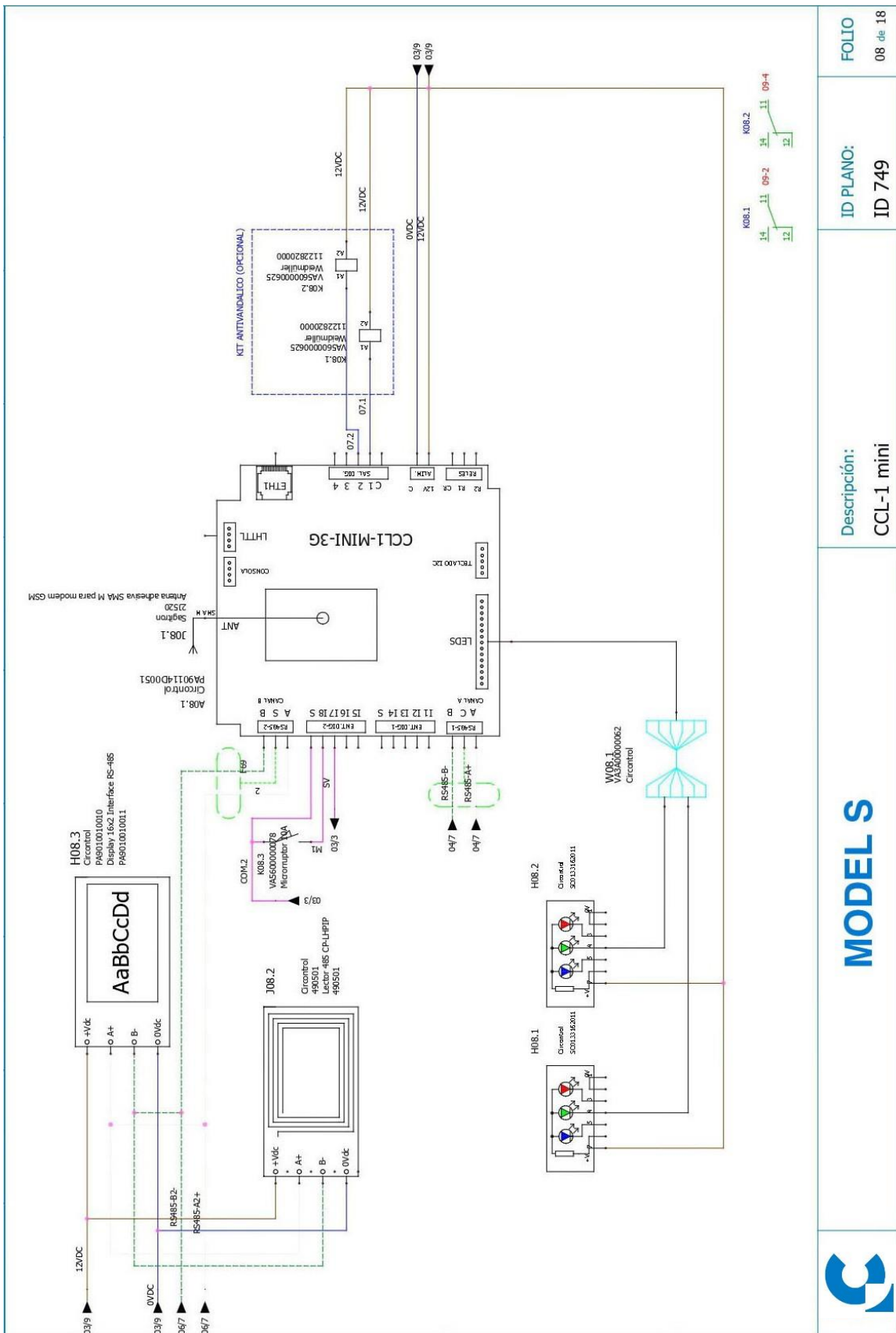

FOLIO	08 de 18
ID PLANO:	ID 749
Descripción:	CCL-1 mini
MODELS	

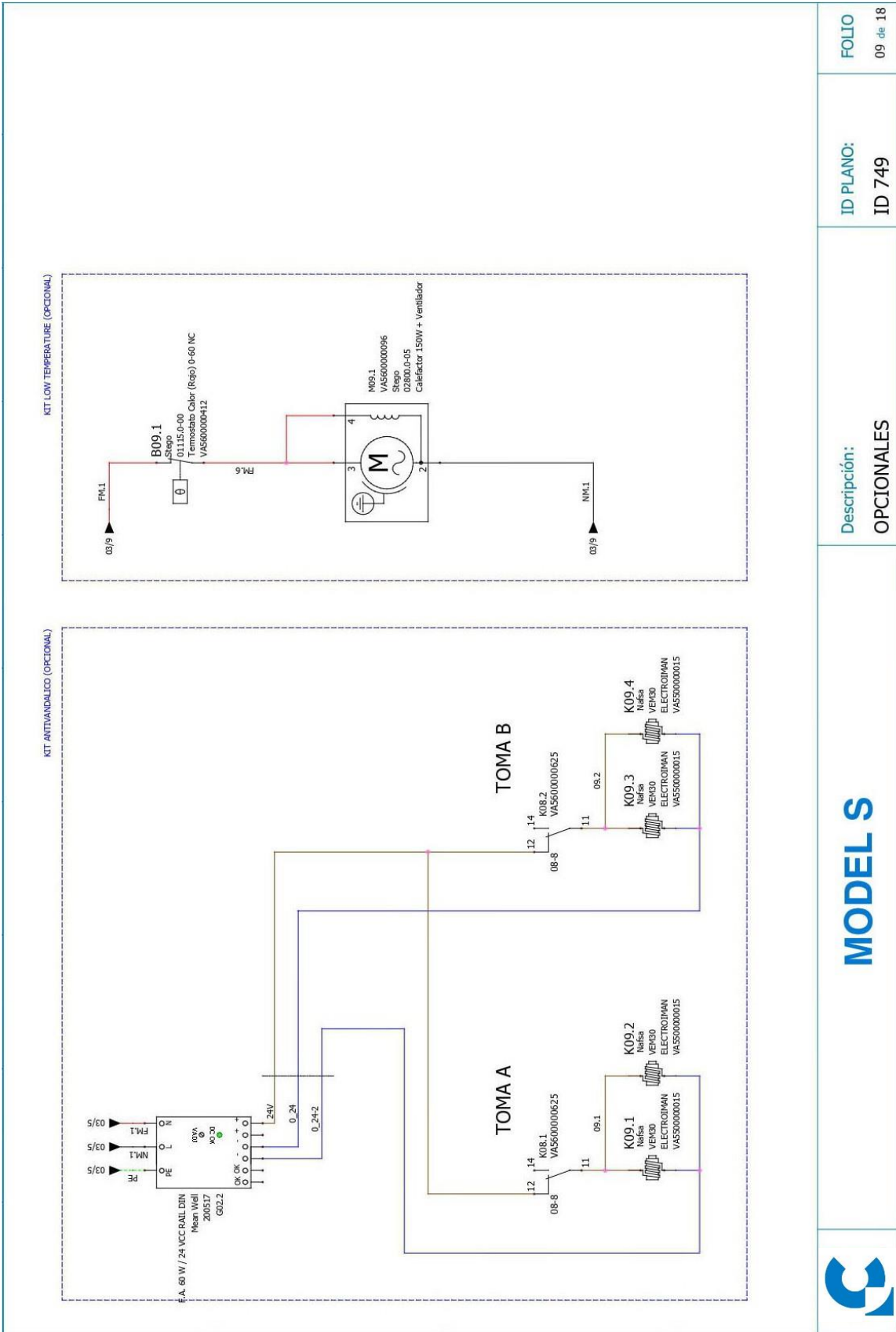

FOLIO
09 de 18

ID PLANO:
ID 749

Descripción:
OPCIONALES

MODELS



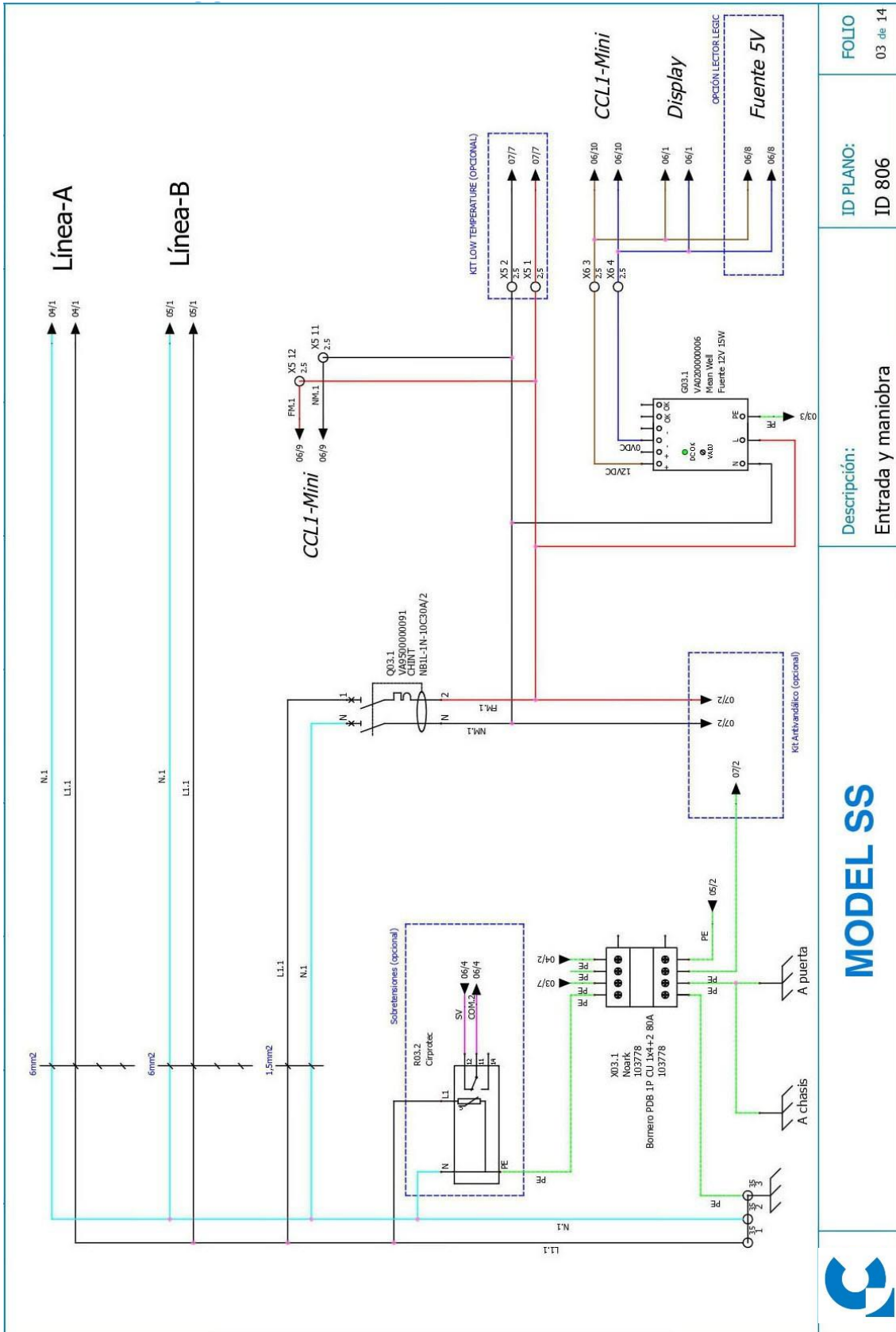

MODEL SS

Descripción:
 Entrada y maniobra

ID PLANO:
 ID 806

FOLIO
 03 de 14

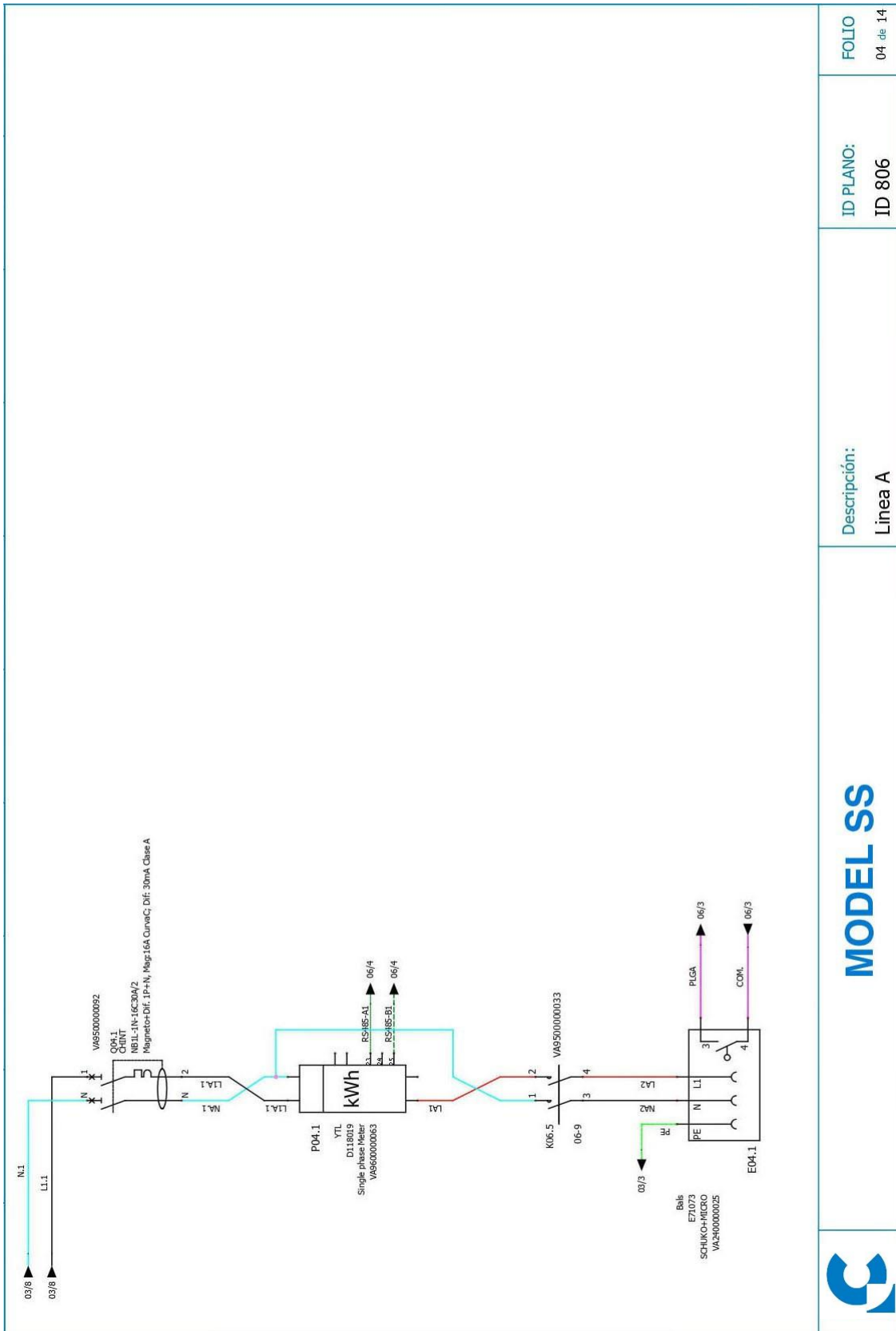

FOLIO
04 de 14

ID PLANO:
ID 806

Descripción:
Linea A

MODEL SS



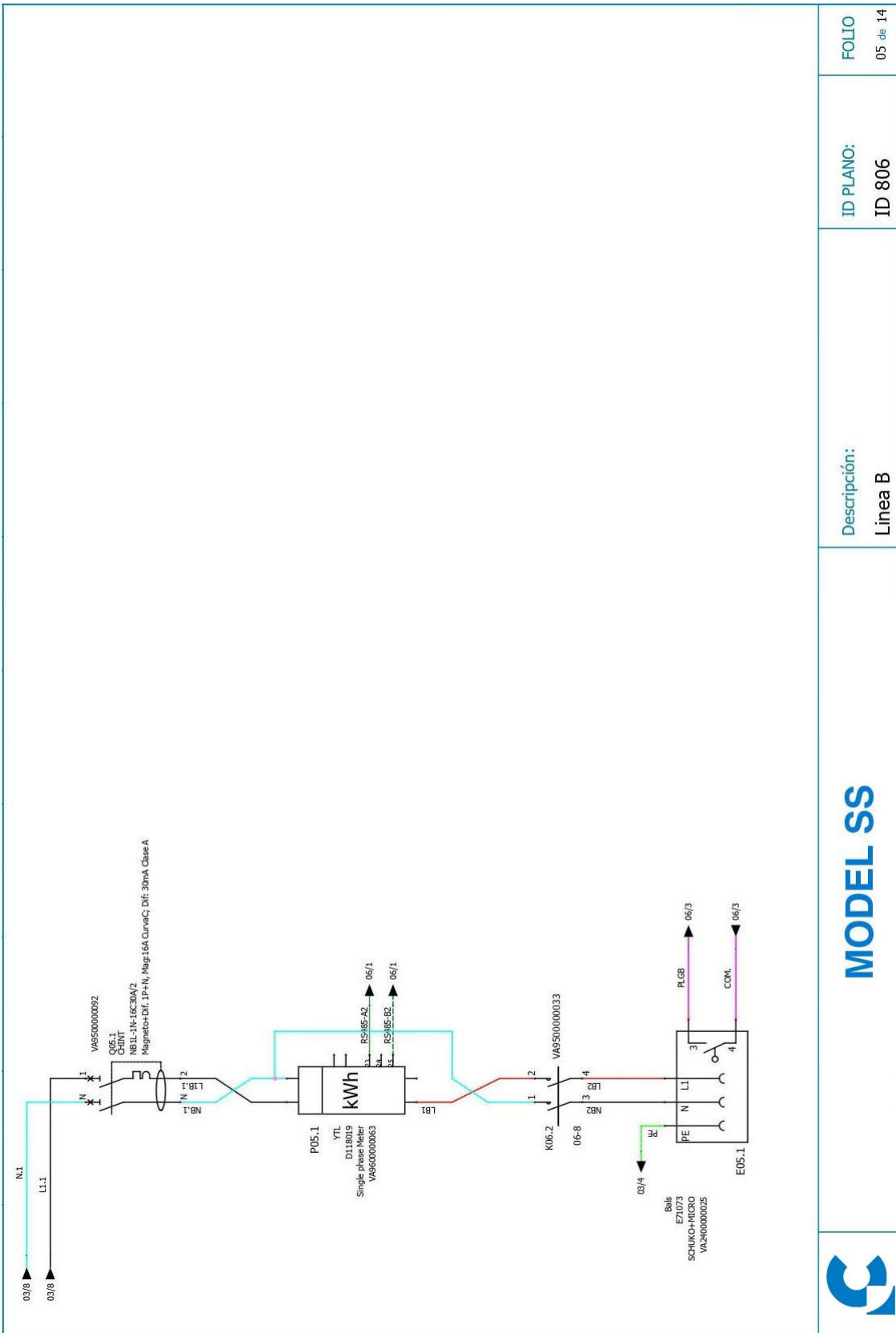

FOLIO
05 de 14

ID PLANO:
ID 806

Descripción:
Linea B

MODEL SS



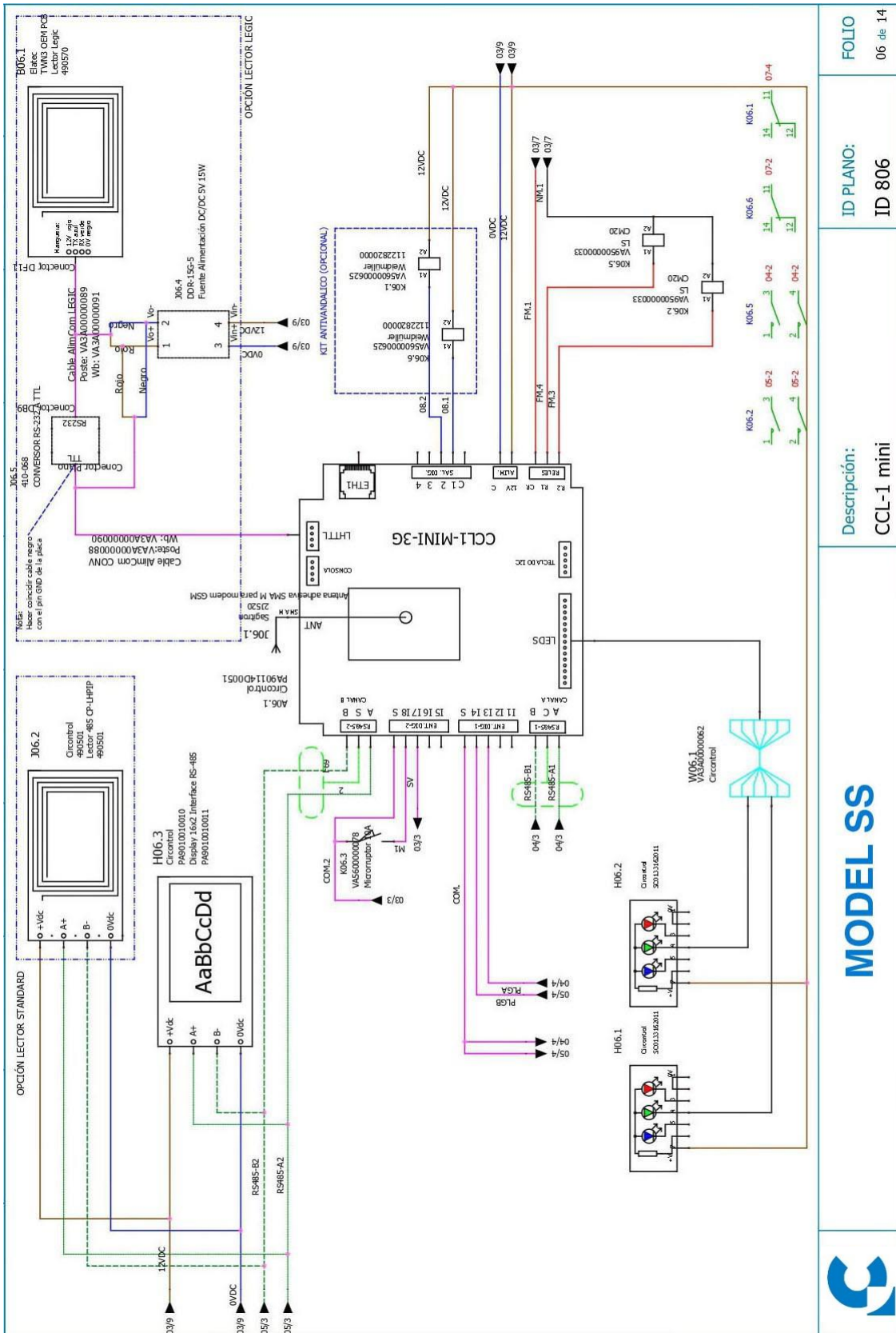

FOLIO 06 de 14
 ID PLANO: ID 806
 Descripción: CCL-1 mini

MODEL SS

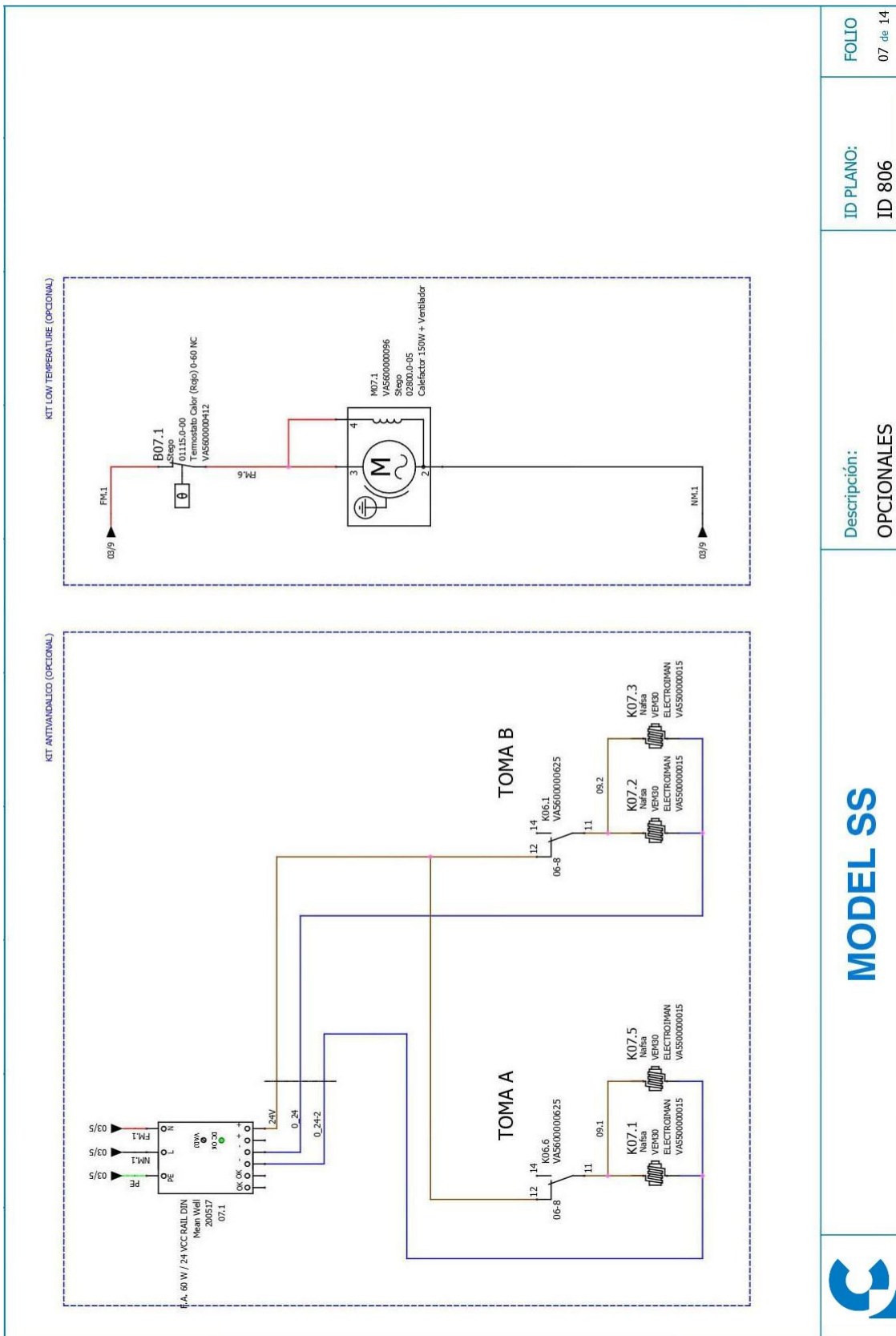

MODEL SS



Descripción:
OPCIONALES

ID PLANO:
ID 806

FOLIO
 07 de 14

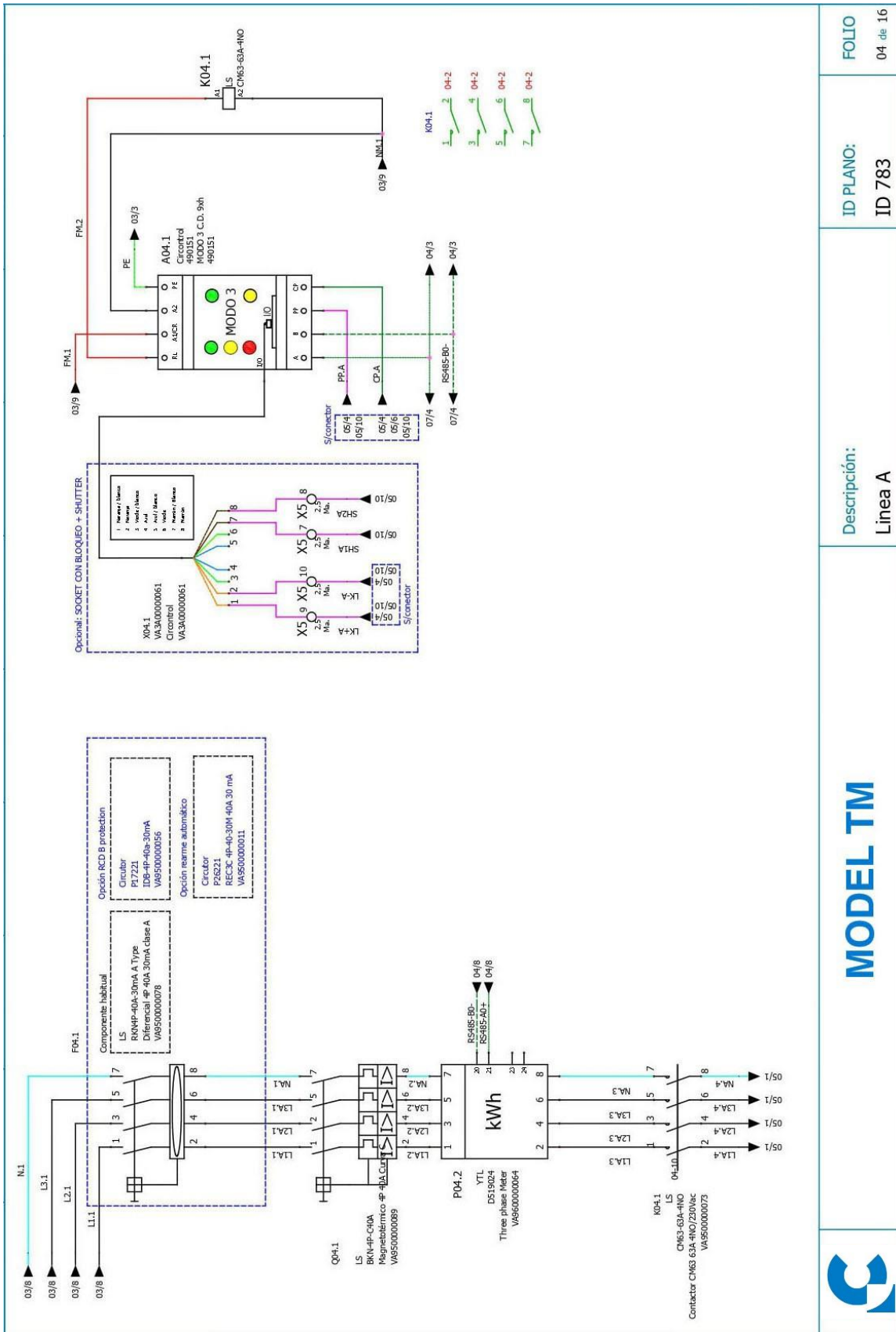

MODEL TM

Descripción:
 Línea A

ID PLANO:
 ID 783

FOLIO
 04 de 16

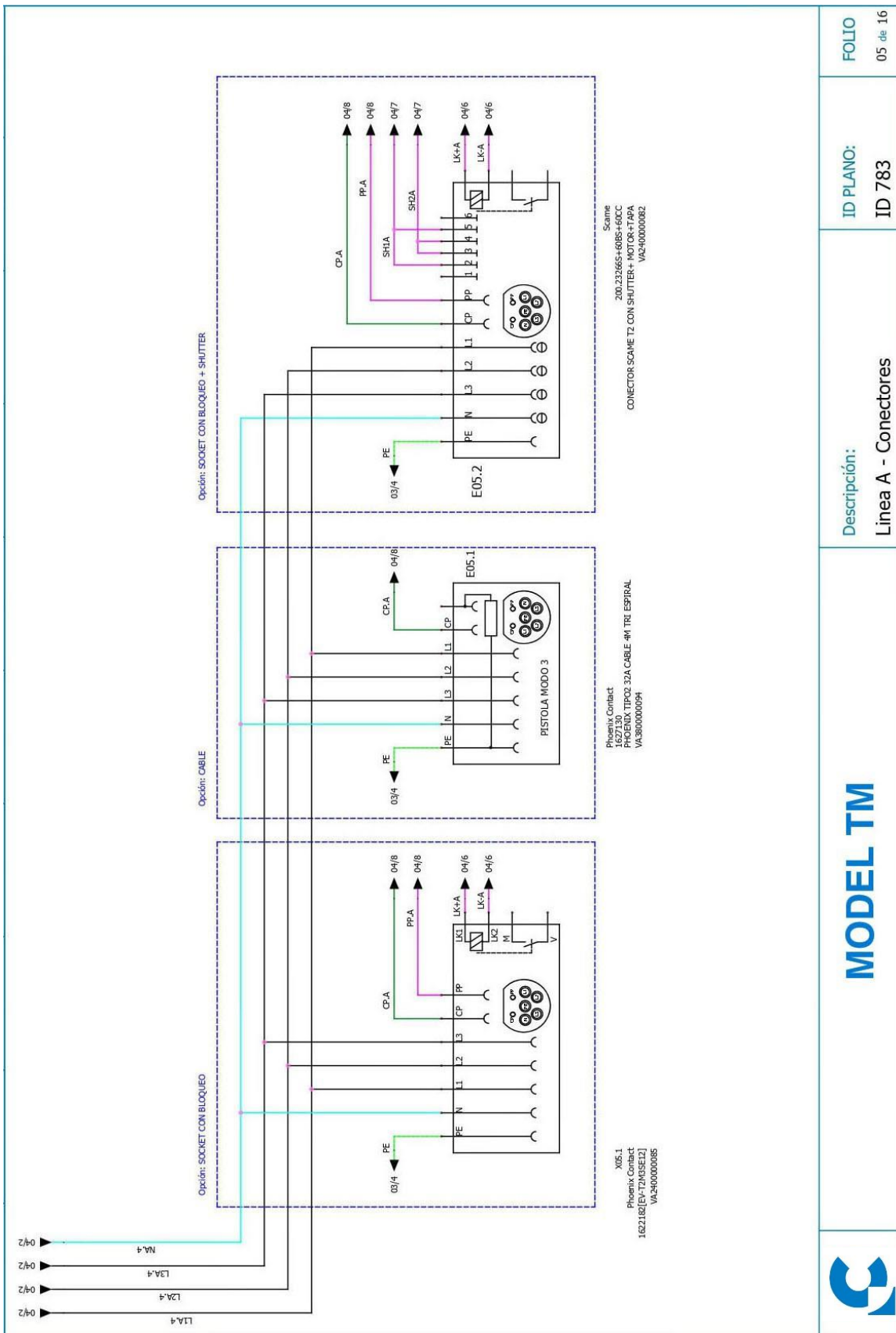

MODEL TM

Descripción:
 Línea A - Conectores

ID PLANO:
 ID 783

FOLIO
 05 de 16

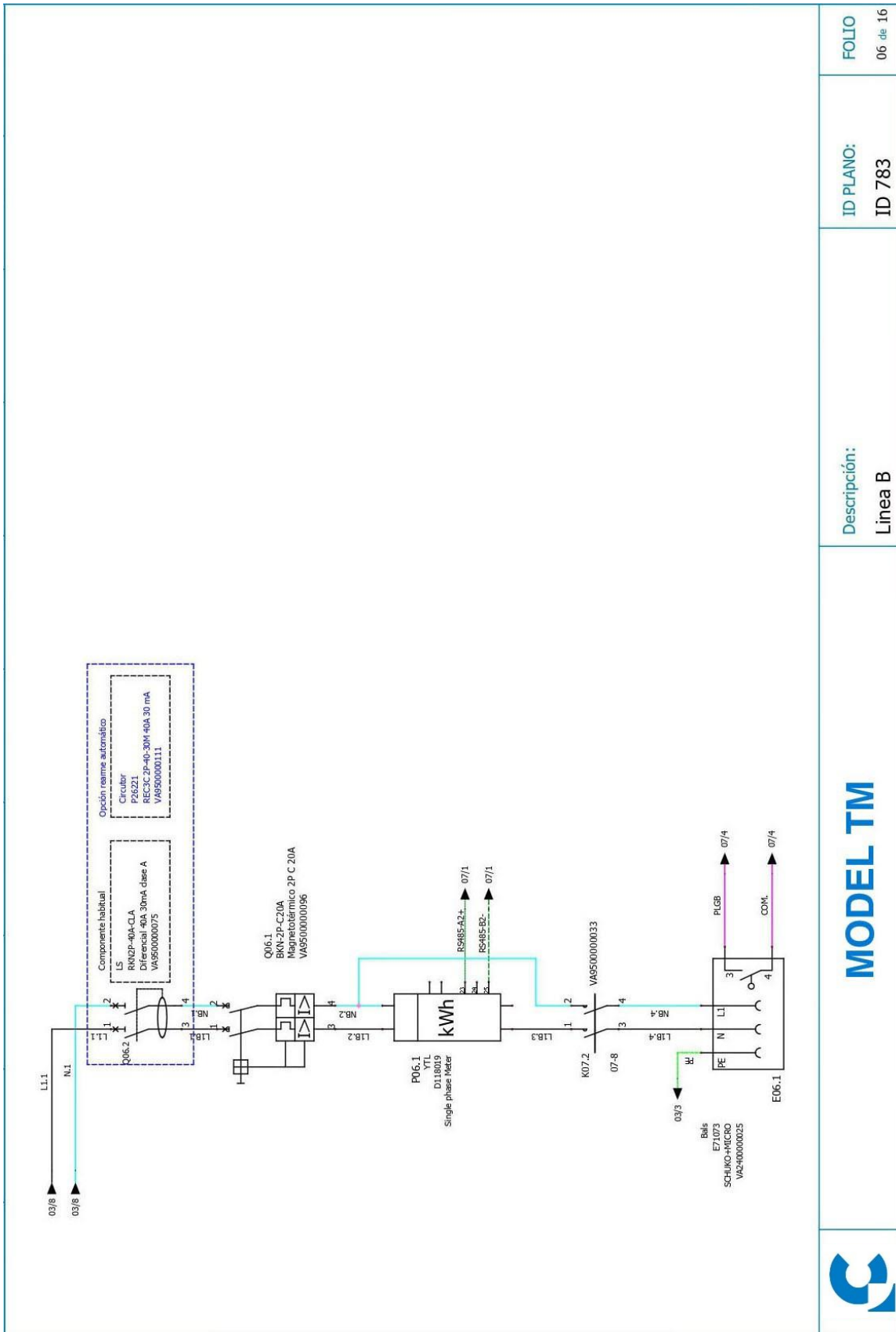

MODEL TM



Descripción:
 Línea B

ID PLANO:
 ID 783

FOLIO
 06 de 16

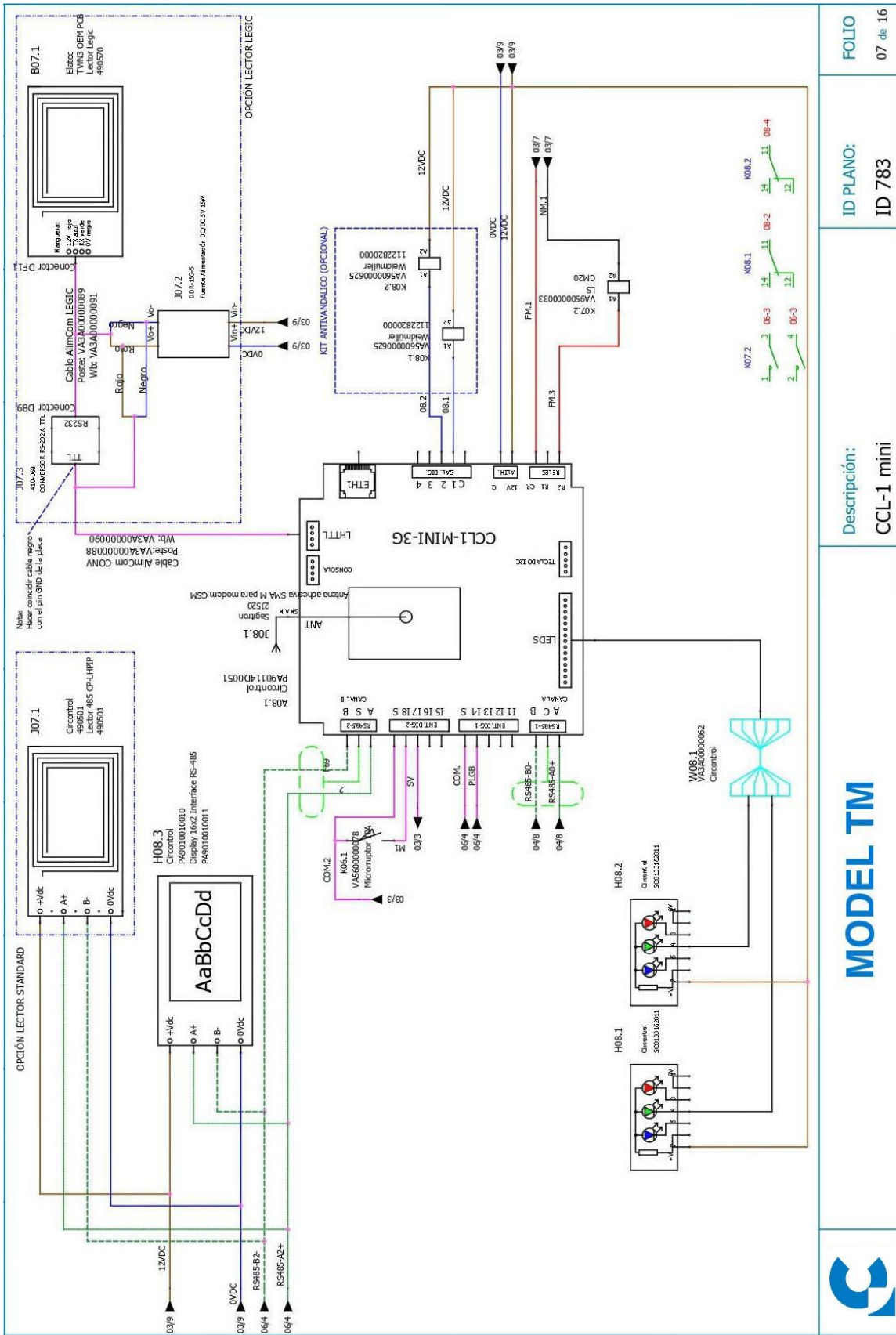

FOLIO
07 de 16

ID PLANO:
ID 783

Descripción:
CCL-1 mini

MODEL TM



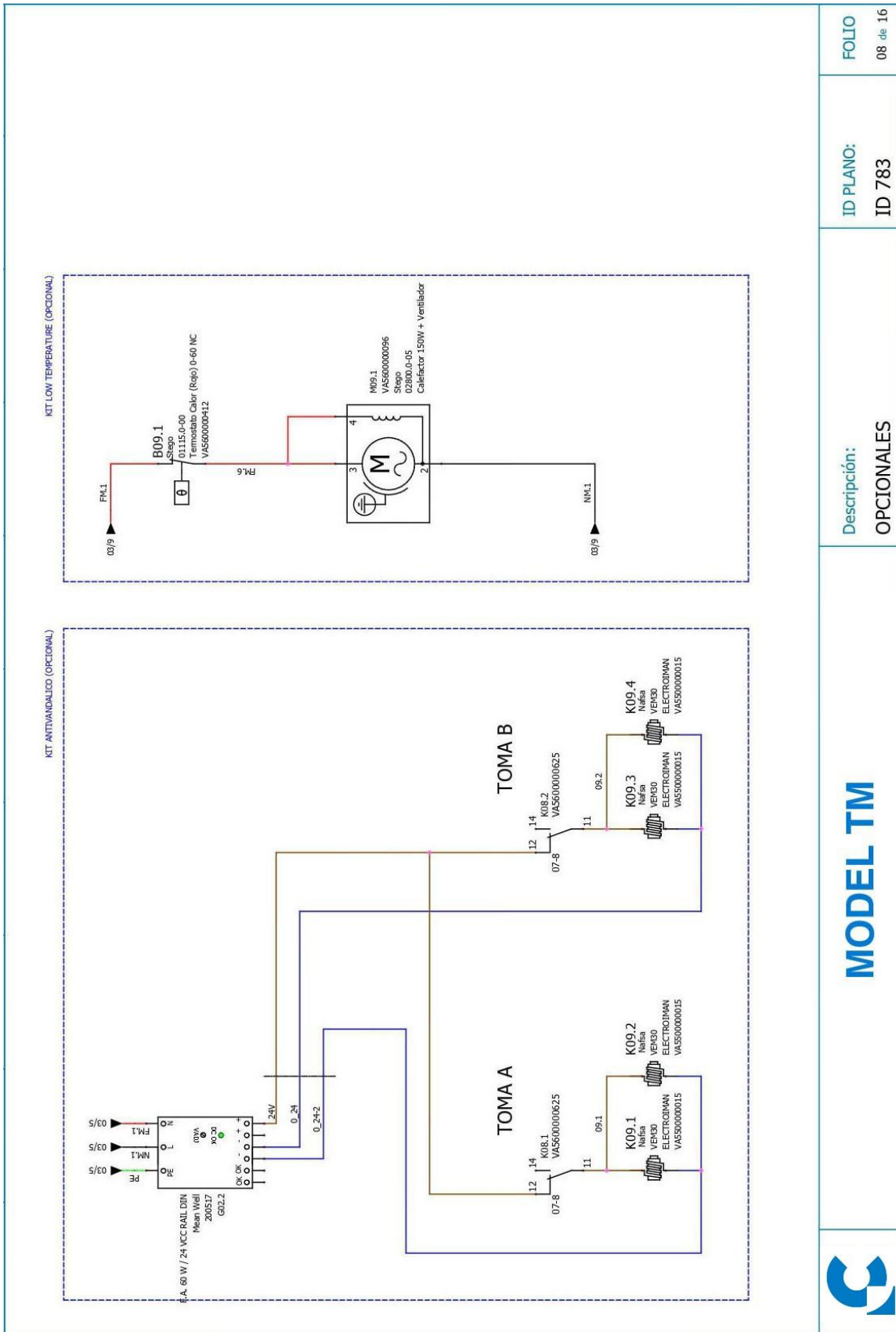

FOLIO
08 de 16

ID PLANO:
ID 783

Descripción:
OPCIONALES

MODEL TM



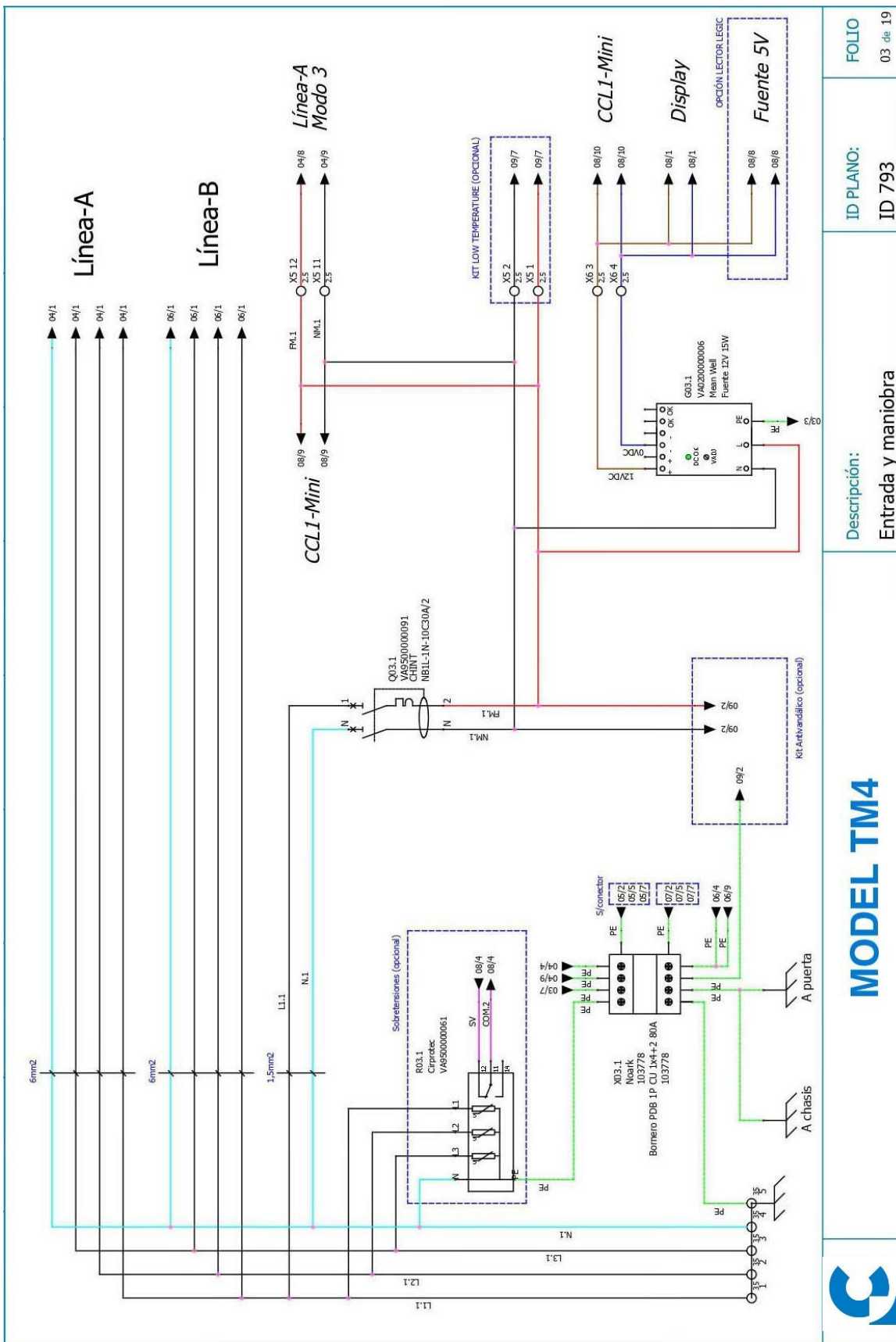

MODEL TM4

FOLIO 03 de 19

ID PLANO: ID 793

Descripción: Entrada y maniobra

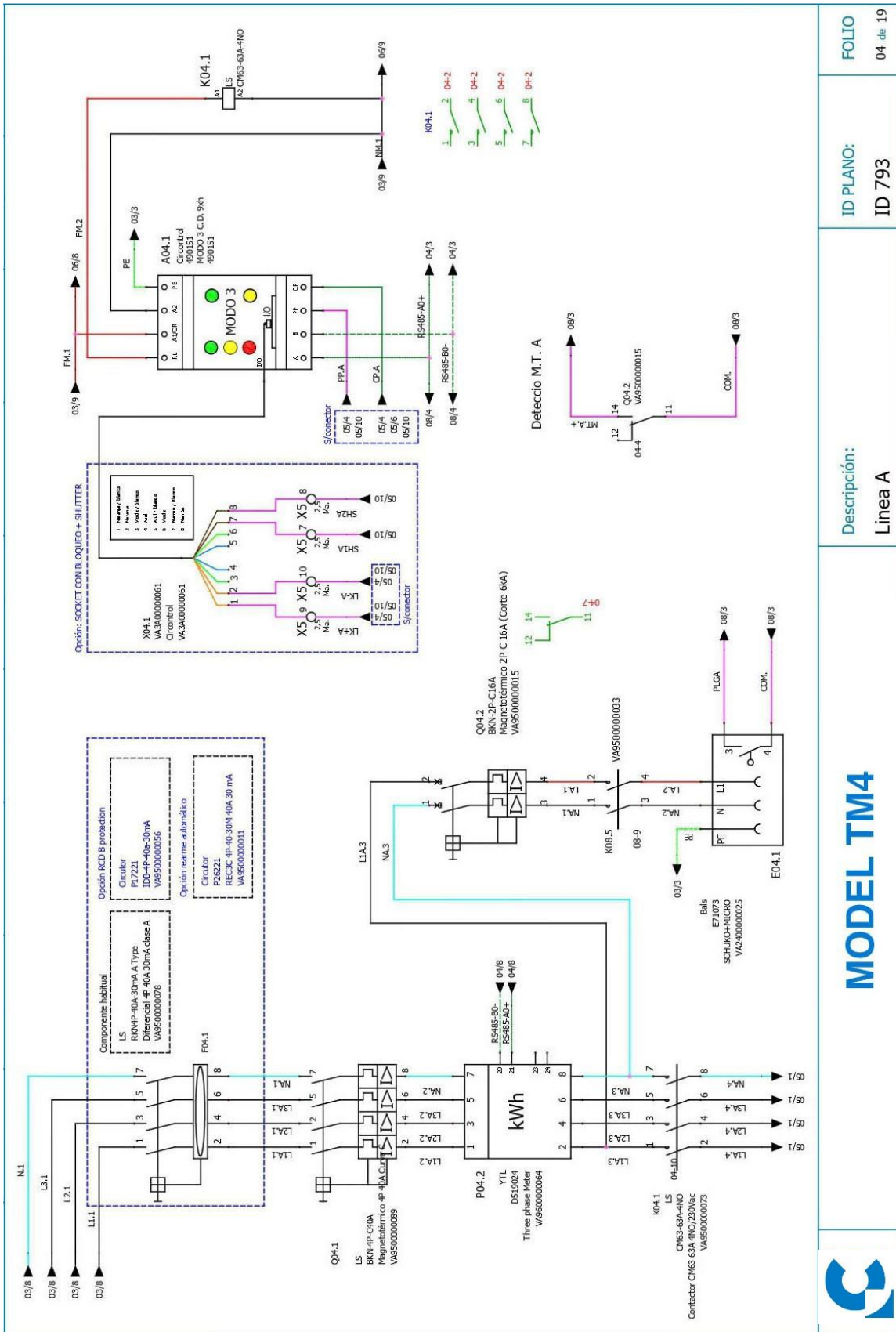

MODEL TM4

Descripción:
Linea A

ID PLANO:
ID 793

FOLIO
04 de 19

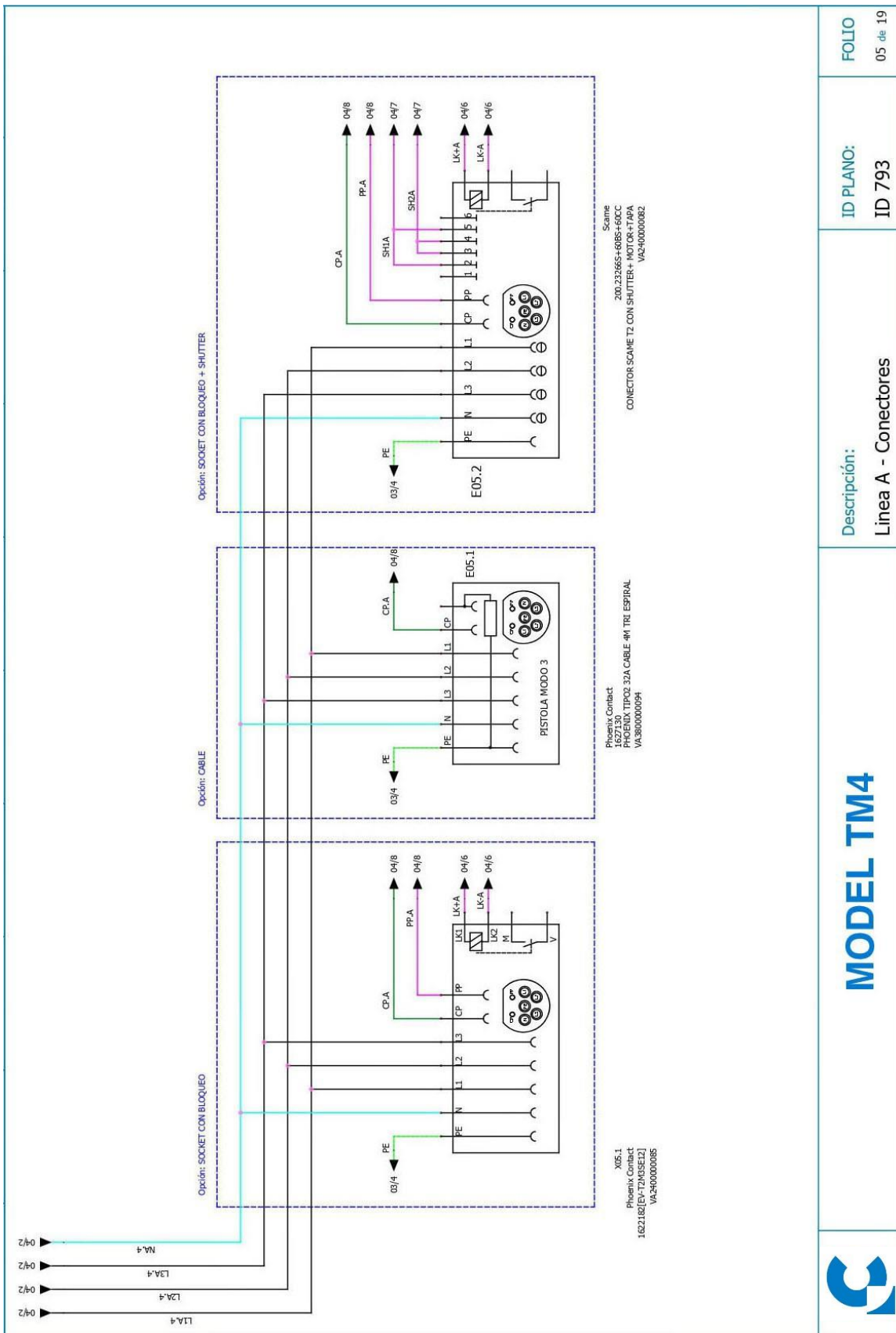

MODEL TM4

Descripción:
 Línea A - Conectores

ID PLANO:
 ID 793

FOLIO
 05 de 19

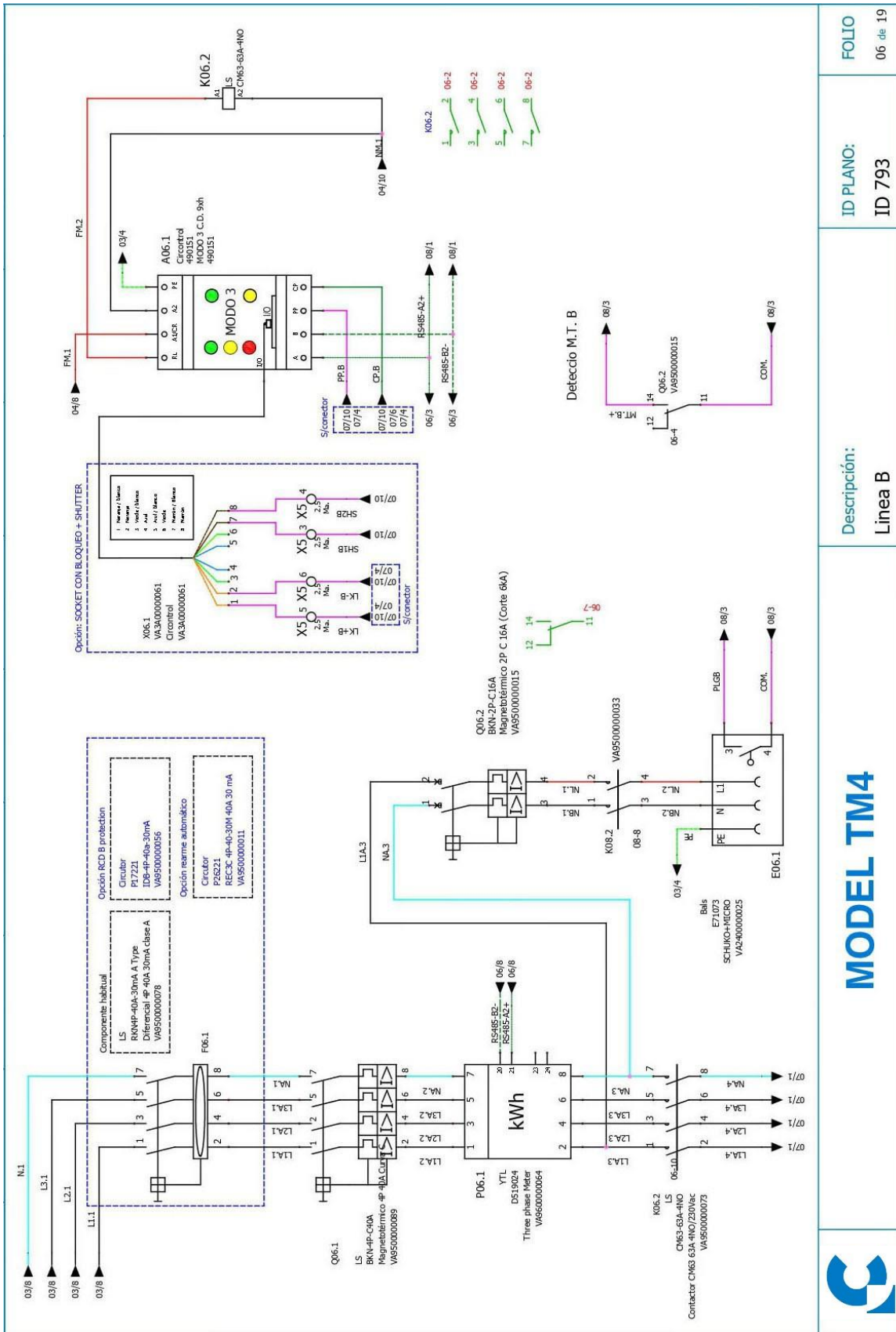

FOLIO
06 de 19

ID PLANO:
ID 793

Descripción:
Linea B

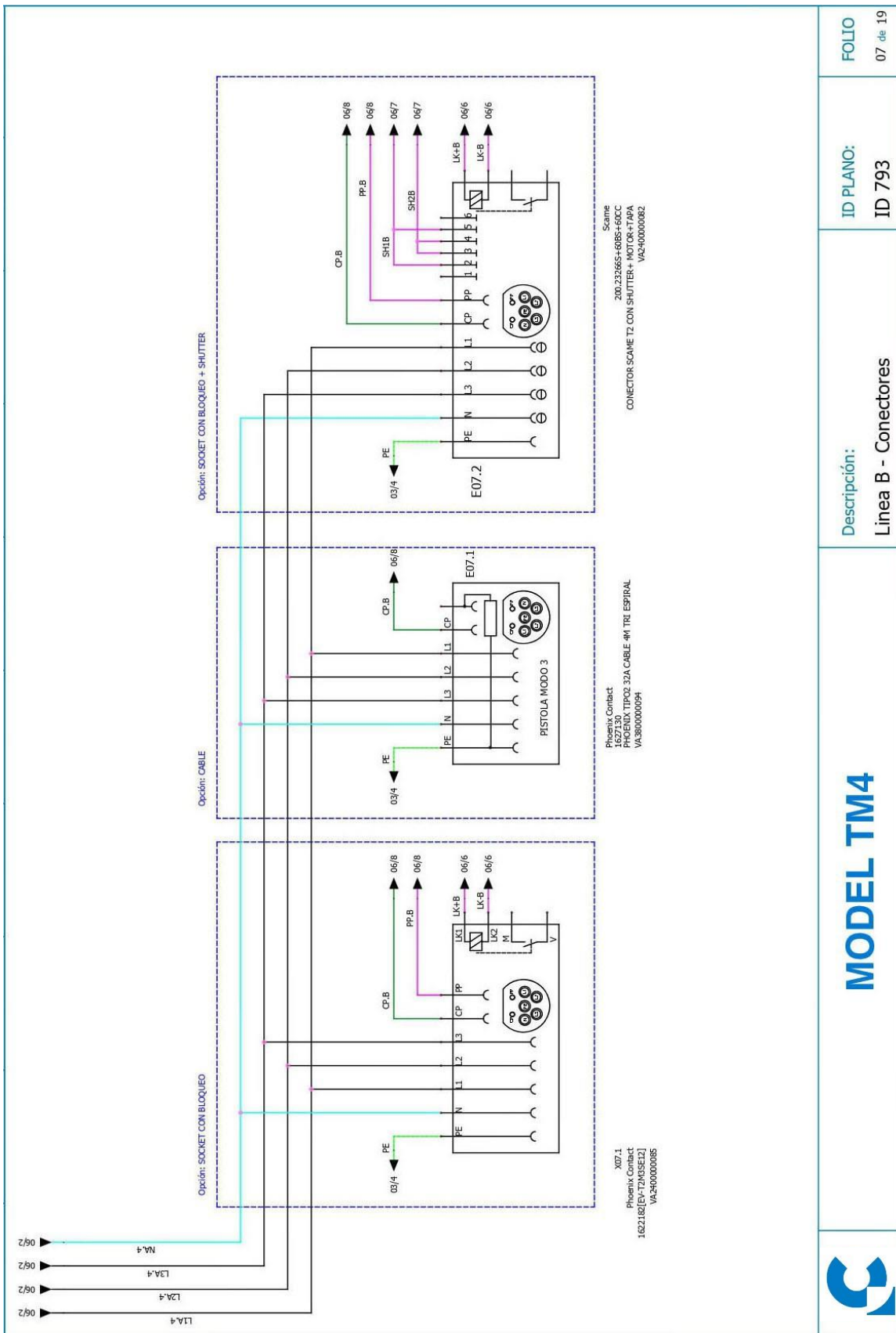

MODEL TM4

Descripción:
 Línea B - Conectores

ID PLANO:
 ID 793

FOLIO
 07 de 19

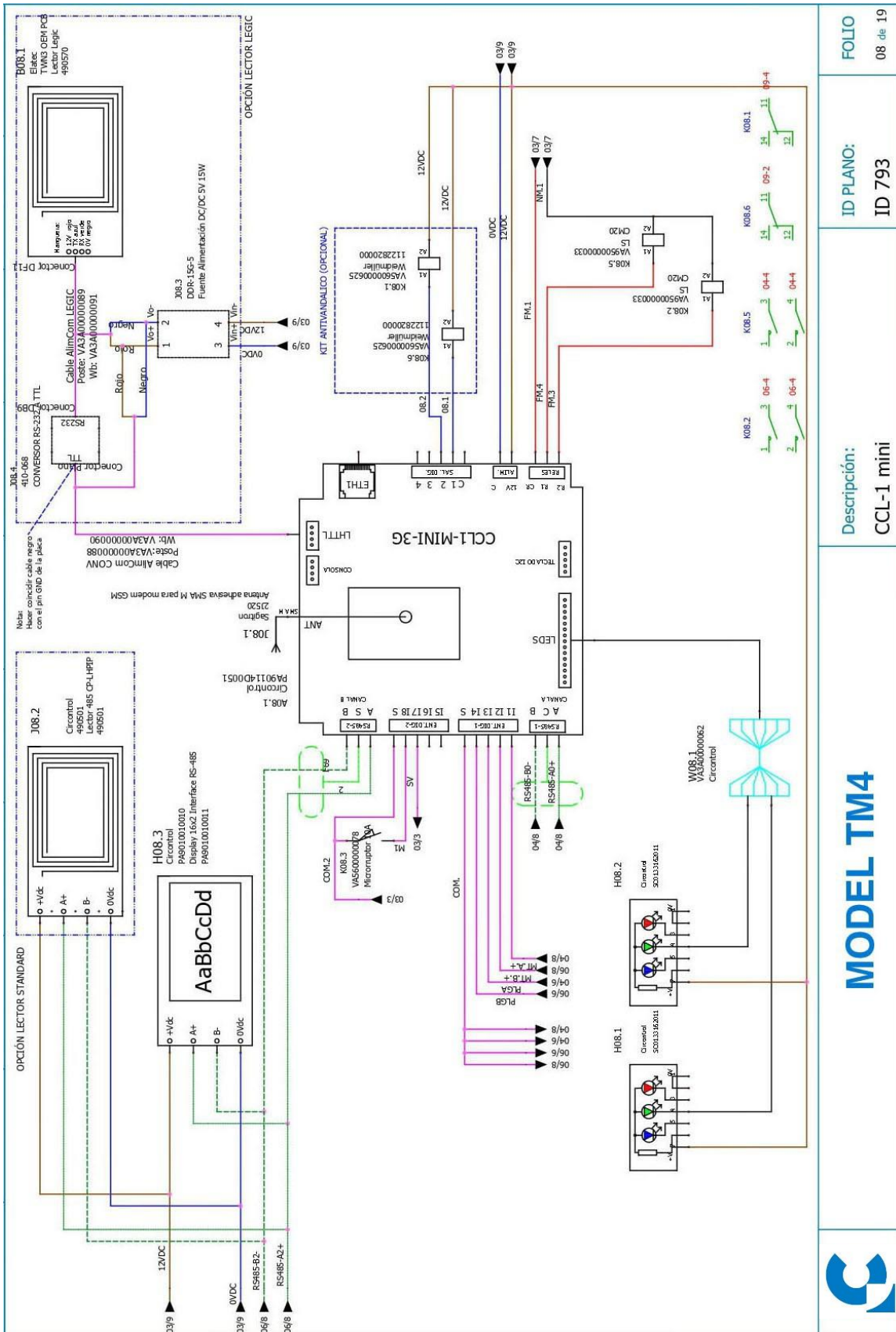

FOLIO
08 de 19

ID PLANO:
ID 793

Descripción:
CCL-1 mini

MODEL TM4



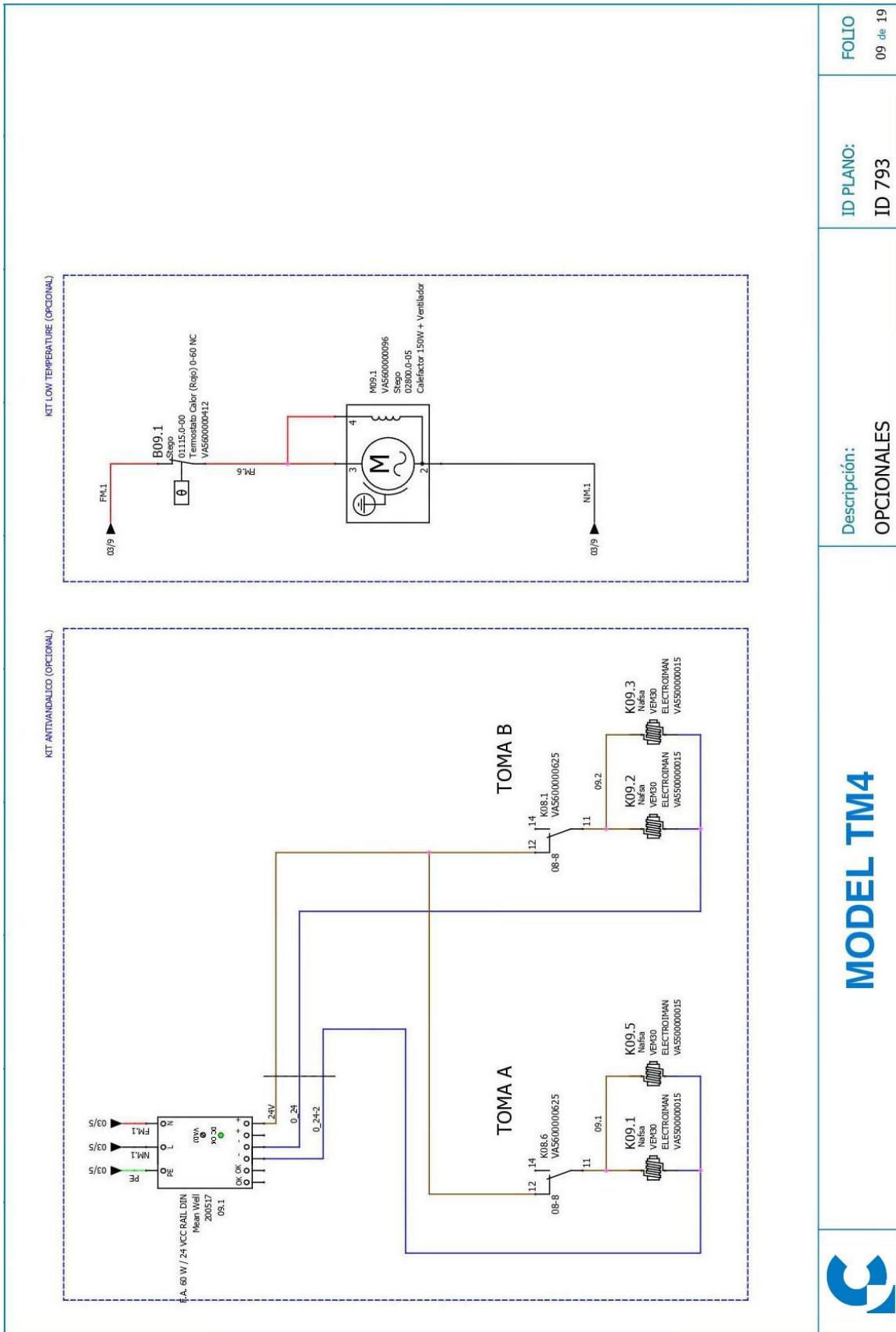

MODEL TM4



FOLIO
09 de 19

ID PLANO:
ID 793

Descripción:
OPCIONALES

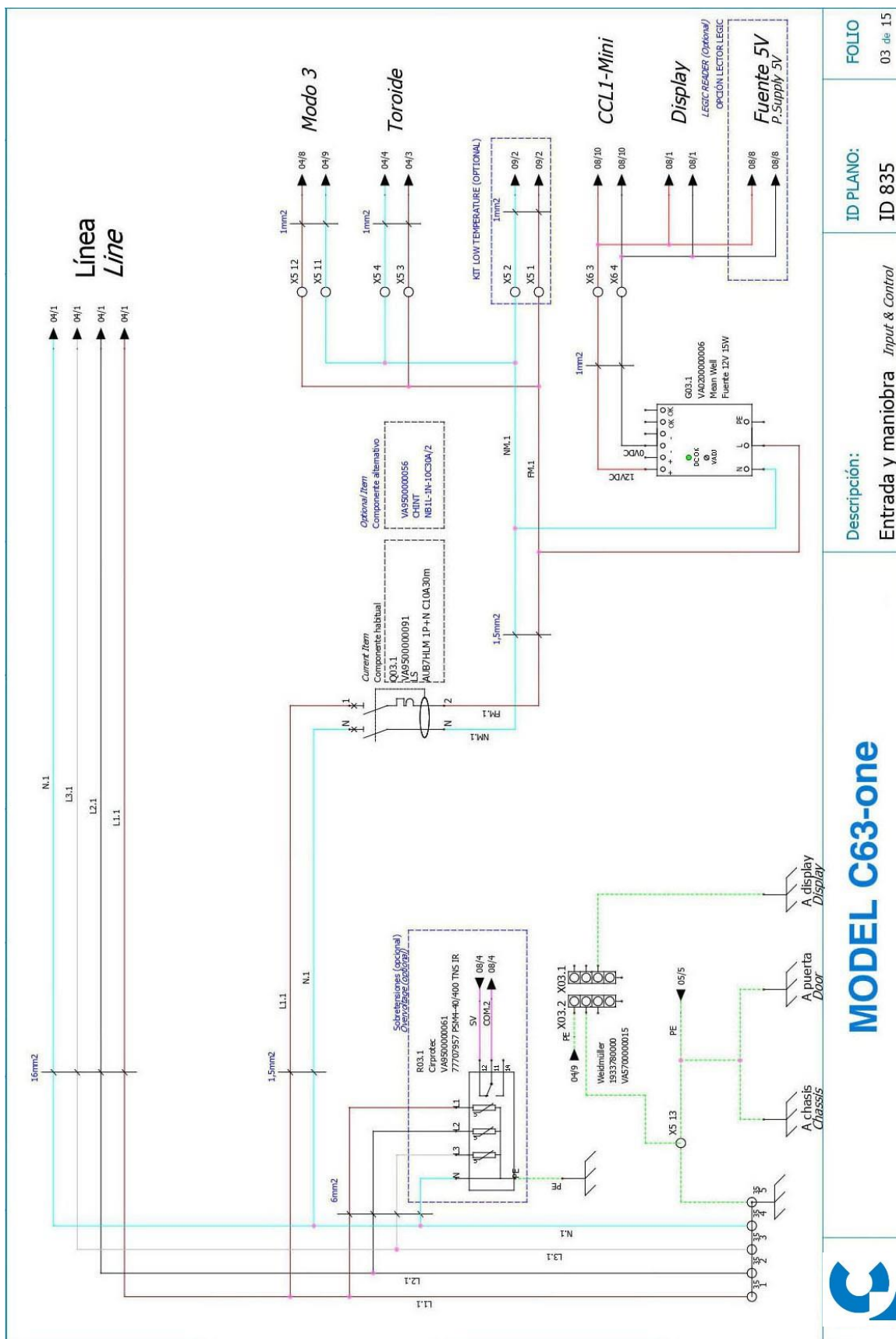

FOLIO
03 de 15

ID PLANO:
ID 835

Descripción:
Entrada y maniobra Input & Control

MODEL C63-one



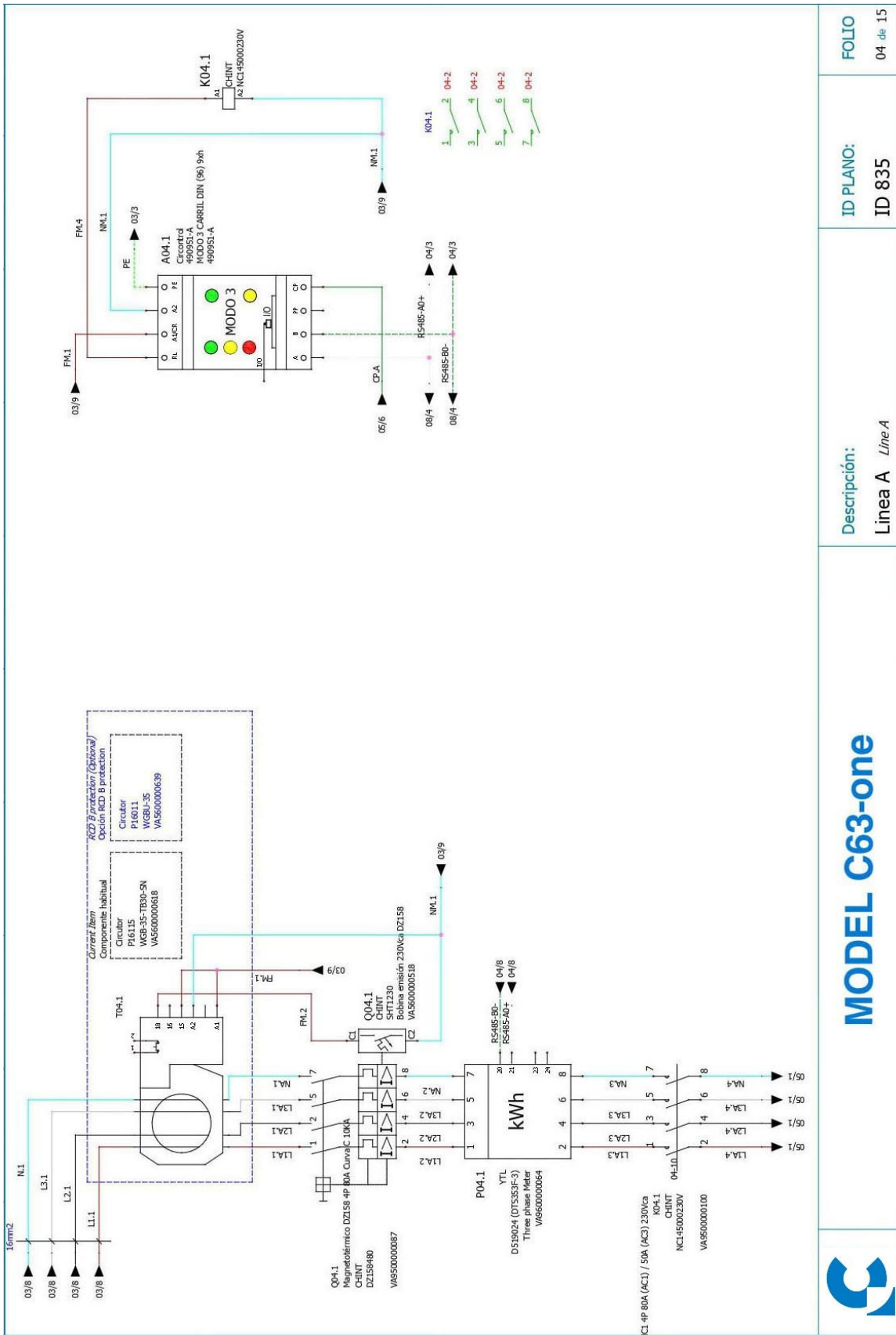

MODEL C63-one

Descripción:
 Linea A Line A

ID PLANO:
 ID 835

FOLIO
 04 de 15

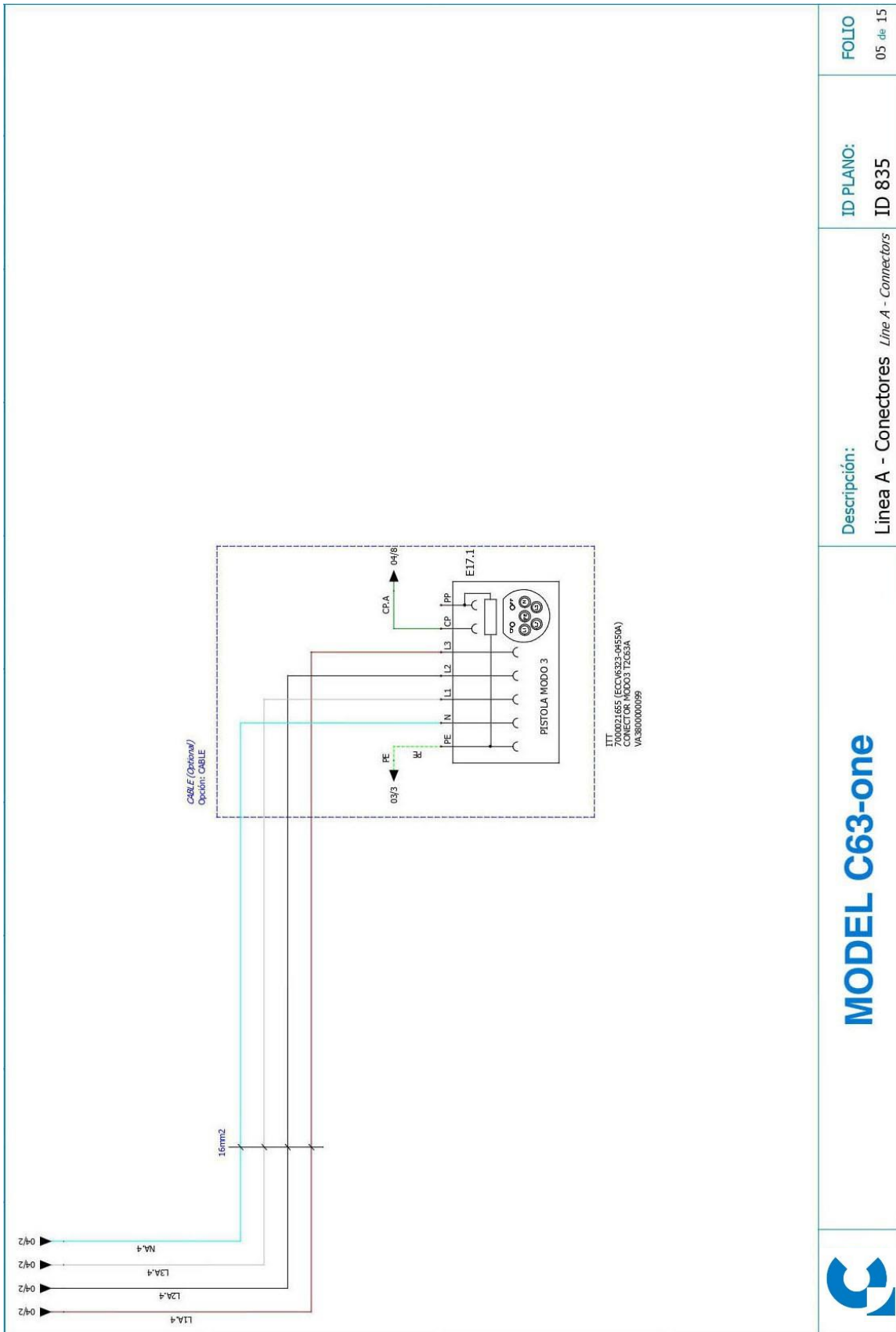

FOLIO
05 de 15

ID PLANO:
ID 835

Descripción:
Linea A - Conectores Linea A - Connectors



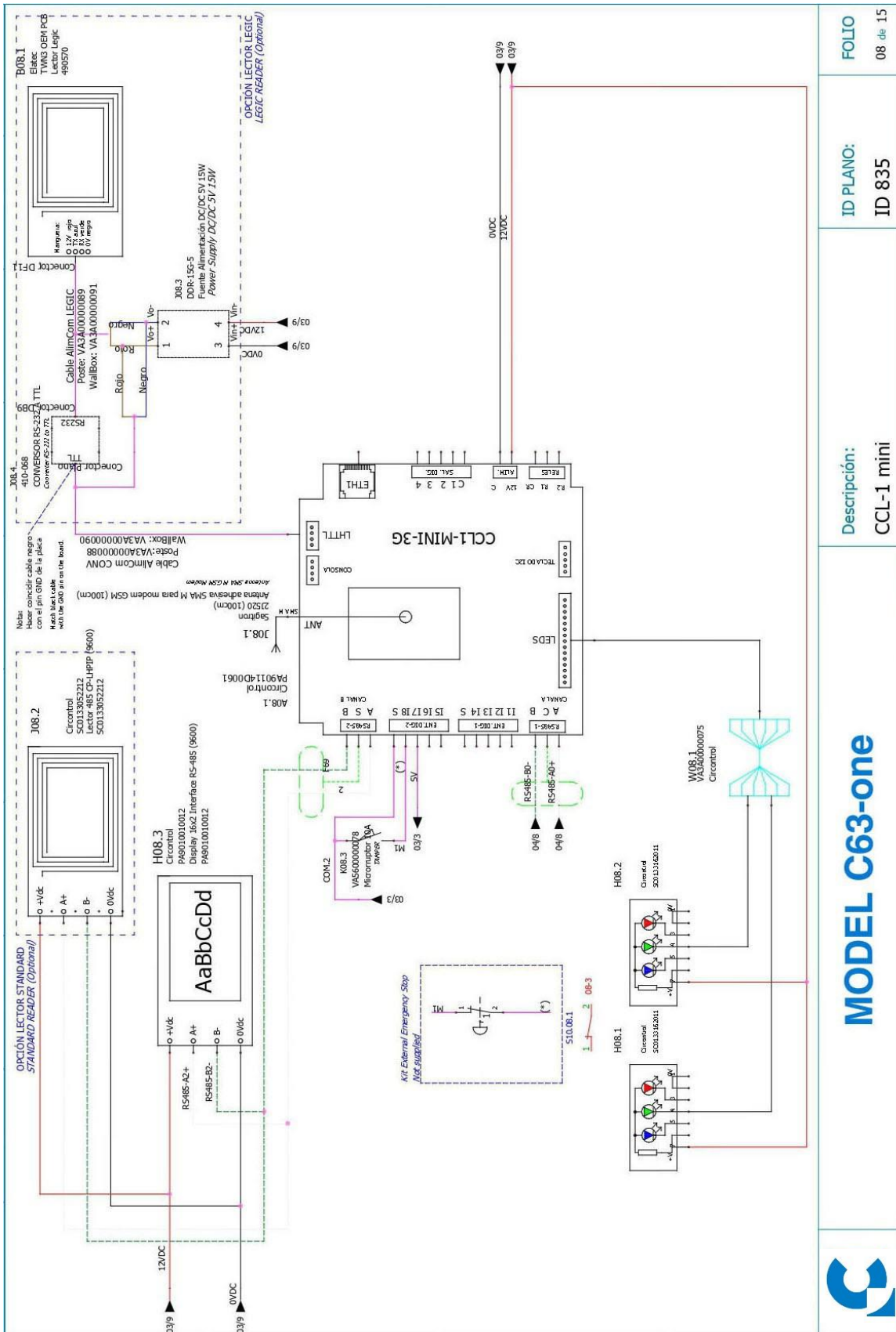

FOLIO 08 de 15
ID PLANO: ID 835
Descripción: CCL-1 mini
MODEL C63-one



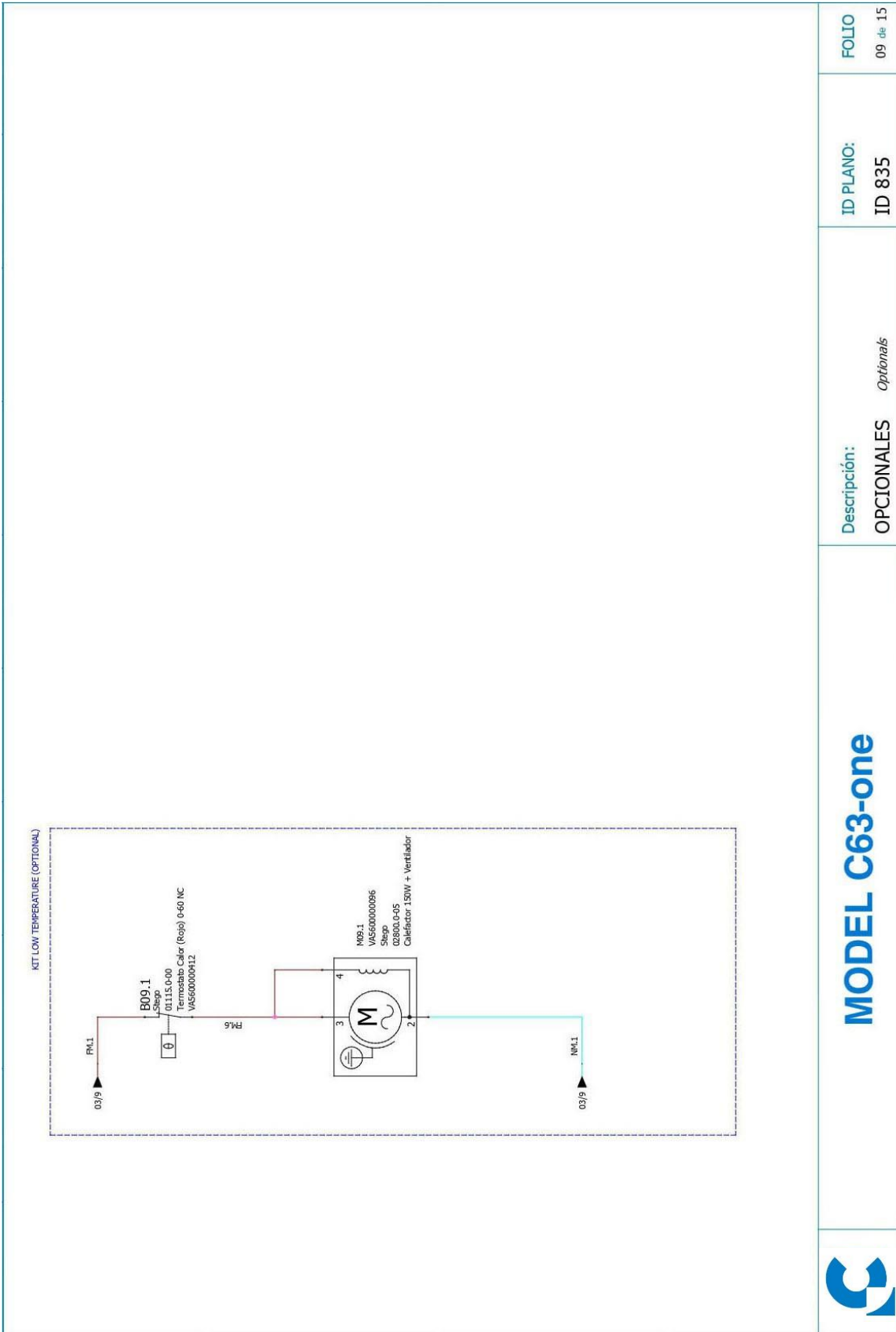

16 NEED HELP?

In case of any query or if further information is required, please contact our **Post-Sales Department**.



support@circontrol.com



Circontrol.com



(+34) 937 362 940



(+34) 937 362 941



**CIRCONTROL
POST eVOLVE SMART
SERVICE MANUAL**

A comprehensive guide on how
to service your Charge Point.

v1.2 - June 2023