

Installation and Operation Manual

MaxiCharger DC Compact (EU)

Trademarks

Autel® and MaxiCharger® are trademarks of Autel Intelligent Technology Corp., Ltd., registered in China, the United States and other countries. All other marks are trademarks or registered trademarks of their respective holders.

Copyright Information

No part of this manual may be reproduced, stored in a retrieval system or transmitted, in any form or by any means, electronic, mechanical, photocopying, recording, or otherwise without the prior written permission of Autel.

Disclaimer of Warranties and Limitation of Liabilities

All information, specifications and illustrations in this manual are based on the latest information available at the time of printing.

Autel reserves the right to make changes at any time without notice. While information of this manual has been carefully checked for accuracy, no guarantee is given for the completeness and correctness of the contents, including but not limited to the product specifications, functions, and illustrations.

Autel will not be liable for any direct, special, incidental, indirect damages or any economic consequential damages (including the loss of profits).

! IMPORTANT

Before operating or maintaining this unit, please read this manual carefully, paying extra attention to the safety warnings and precautions.

For Services and Support:

Web: www.autelenergy.com

Tel: +49 (0) 89 540299608 (Europe)

Email: evsupport.eu@autel.com

For technical assistance in all other markets, please contact your local selling agent.

CONTENTS

1 USING THIS MANUAL	1
1.1 CONVENTIONS	1
1.1.1 <i>Bold Text</i>	1
1.1.2 <i>Notes and Important Message</i>	1
1.1.3 <i>Illustrations</i>	1
1.1.4 <i>Revision History</i>	1
2 SAFETY	3
2.1 SAFETY MESSAGES	3
2.2 SAFETY INSTRUCTIONS	3
2.3 DISPOSAL INSTRUCTIONS	4
3 GENERAL INTRODUCTION	5
3.1 PRODUCT OVERVIEW (OUTSIDE)	6
3.2 PRODUCT OVERVIEW (INSIDE)	7
3.3 TECHNICAL SPECIFICATIONS	8
3.4 PRODUCT DIMENSIONS	10
4 PREPARATION	12
4.1 BEFORE YOU BEGIN	12
4.2 INSTALLATION TOOLS.....	13
5 INSTALLATION	14
5.1 UNPACKING	14
5.2 MOVING THE MAXICHARGER	15
5.3 INSTALLING THE PEDESTAL-MOUNTED MAXICHARGER.....	17
5.3.1 <i>Location Requirements</i>	17
5.3.2 <i>Checking the Package</i>	18
5.3.3 <i>Getting Started</i>	20
5.3.4 <i>Completing the Installation</i>	28
5.4 INSTALLING THE TROLLEY-MOUNTED MAXICHARGER	30

5.4.1	<i>Checking the Package</i>	30
5.4.2	<i>Getting Started</i>	32
5.4.3	<i>Completing the Installation</i>	34
5.5	POWER SUPPLY WIRING	36
5.5.1	<i>AC Input Cable Information</i>	36
5.5.2	<i>Opening the Door</i>	37
5.5.3	<i>Connecting the AC Input Cable</i>	38
5.6	CONNECTING TO THE INTERNET	40
5.6.1	<i>Via the Ethernet Cable</i>	40
5.6.2	<i>Via the Cellular Network</i>	41
5.7	INSTALLING THE UPSTREAM PROTECTIVE DEVICE	42
5.8	CONNECTING THE INDUSTRIAL PLUG TO THE SOCKET	42
6	OPERATION	43
6.1	CHARGING PROCEDURE	43
6.1.1	<i>Standby Mode</i>	44
6.1.2	<i>Authorization</i>	45
6.1.3	<i>Start Charging</i>	46
6.1.4	<i>Charging</i>	46
6.1.5	<i>Stop Charging</i>	47
6.1.6	<i>Finish Charging</i>	47
6.2	CHARGING ERRORS	48
6.2.1	<i>Connector Connection Error</i>	48
6.2.2	<i>Authorization Failure</i>	48
6.2.3	<i>Charging Start Failure</i>	48
6.2.4	<i>Charging Failure</i>	48
6.3	EMERGENCY STOP RESPONSE	48
6.4	POWERING DOWN THE MAXICHARGER	49
6.4.1	<i>Measuring the AC Voltage</i>	49

6.4.2	<i>Measuring the DC Voltage</i>	50
6.5	LOCAL SERVICE PORTAL OPERATIONS	51
6.5.1	<i>Setting the OCPP Parameters</i>	51
6.5.2	<i>Configuring the Cloud Platform</i>	51
7	MAINTENANCE	52
7.1	ROUTINE MAINTENANCE	52
7.1.1	<i>Residual Current Device Maintenance</i>	52
7.1.2	<i>Cleaning the MaxiCharger</i>	53
7.1.3	<i>Cleaning and Replacing the Filter</i>	53
7.2	INSPECTION AND MAINTENANCE	55
7.3	REMOTE MAINTENANCE	55
7.4	MAINTENANCE SCHEDULE	56
8	TROUBLESHOOTING AND SERVICE	57
8.1	TROUBLESHOOTING	57
8.2	SERVICE	59

1 Using This Manual

This manual provides the procedures for installing and operating of the MaxiCharger DC Compact. Read through this manual and become familiarized with the instructions of the MaxiCharger prior to installation to ensure successful use.

This document is intended for these groups:

- Owner of the MaxiCharger
- Installation Engineer

1.1 Conventions

1.1.1 Bold Text

Bold text is used to highlight selectable items such as buttons and menu options.

1.1.2 Notes and Important Message

Notes

A **NOTE** provides helpful information such as additional explanations, tips, and comments.

Important

IMPORTANT indicates a situation that, if not avoided, may result in damage to the test equipment or vehicle.

1.1.3 Illustrations

Illustrations used in this manual are only examples; the actual product(s) or screens may vary.

1.1.4 Revision History

Version	Date	Descriptions
V1	2022.11.25	Initial version
V2	2023.02.20	Complete overhaul
V2.1	2023.05.05	Product name revision Linguistic revision

		2.1 Fire protection added
		2.2 Disposal instructions added
		3.4 Product dimensions added
		5. Installation updated
		6.3 Emergency stop response added
		6.5 Configuring the cloud platform added
V3	2023.07.04	Side cover of the charger updated
		Most figures updated
		Technical specifications updated
		Packing List updated
		Section 5.3/5.4/5.5 updated
		Section 6.3 updated

2 Safety

For your own safety and the safety of others, and to prevent damage to the device and vehicles upon which it is used, it is important that the safety instructions presented throughout this manual be read and understood by all persons operating or coming into contact with the device.

2.1 Safety Messages

Safety messages are provided to help prevent personal injury and equipment damage. All safety messages are introduced by a single word indicating the hazard level.

 **DANGER**

Indicates an imminently hazardous situation with a high risk level which, if the danger is not avoided, will cause death or serious injury.

 **WARNING**

Indicates a potentially hazardous situation with moderate risk level which, if the warning is not obeyed, can cause death or serious injury.

 **CAUTION**

Indicates a potentially hazardous situation with a medium risk level which, if the caution is not obeyed, may cause minor or moderate injury or damage to the equipment.

2.2 Safety Instructions

The safety messages herein cover situations Autel is aware of. Autel cannot know, evaluate or advise you as to all of the possible hazards. You must be certain that any condition or service procedure encountered does not jeopardize your personal safety.

 **SAFETY WARNINGS**

- Disconnect the power supply to the MaxiCharger during the entire installation procedure.
- The load capacity of the grid must meet the requirements of the MaxiCharger.
- Connect the MaxiCharger to a grounded, metal, permanent wiring system. Otherwise, use the equipment-grounding conductor with the circuit conductors and connect it to the equipment grounding terminal or lead on the product.
- Unqualified personnel must keep a safe distance during the entire installation procedure.
- The connections to the MaxiCharger must comply with all applicable local rules.
- Only use electrical wires of sufficient gauge and insulation to handle the rated current and voltage demand.

- Protect the wiring inside the MaxiCharger from damage and do not obstruct the wiring when you perform maintenance on the cabinet.
- Protect the MaxiCharger with safety devices and measures as specified by local rules.
- Do not install or use this equipment near flammable, explosive, harsh, or combustible materials, chemicals or vapors.
- If applicable, install a fire alarm system nearby this equipment to detect early fires.
- **If any specifications or regulations mentioned in this manual contradict with your local rules, refer to your local rules.**

2.3 Disposal Instructions

Handling waste incorrectly can have a negative effect on the environment and human health due to potential hazardous substances. Discard the charging station correctly can facilitate the reuse and recycling the materials and environmental protection.

- Obey the local rules when discarding parts, packaging materials or the charging station.
- Discard electrical and electronic equipment separately in compliance with the WEEE-2012/19/EU Directive on waste of electrical and electronic equipment.
- Do not mix or dispose the charging station with the household waste.

3 General Introduction

The MaxiCharger DC Compact is designed to charge an electric vehicle (hereinafter called EV). Our chargers provide safe, reliable, fast, and smart charging solutions.

This MaxiCharger is intended for the DC charging of EVs and is intended for both indoor and outdoor use:

- Fleets
- Highway rest stops
- Commercial parking garages
- Other locations



DANGER

- Do not operate the equipment in any ways other than described in this manual or other related documents. Not following the instructions may cause potential personal injury and/or damage to the property.
- Use the MaxiCharger only as intended.



NOTE

The images and illustrations depicted in this manual may slightly differ from the actual product.

This manual will instruct you how to install and operate the MaxiCharger.

3.1 Product Overview (Outside)

1. Ambient Light Sensor
2. Touchscreen
3. RFID Card Reader
4. POS Payment Device (optional)
5. EV Charging Cable
6. Ethernet Cable Port
7. AC Inlet Hole
8. Vent — each on the right and left side
9. Lock
10. Groove
11. Lifting Handle
12. Bezel

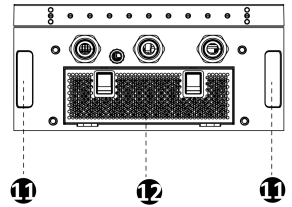
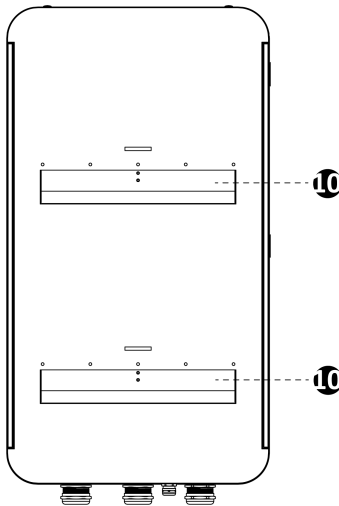
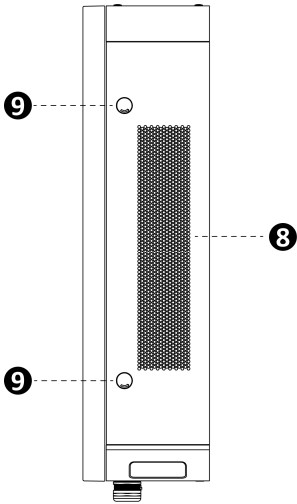
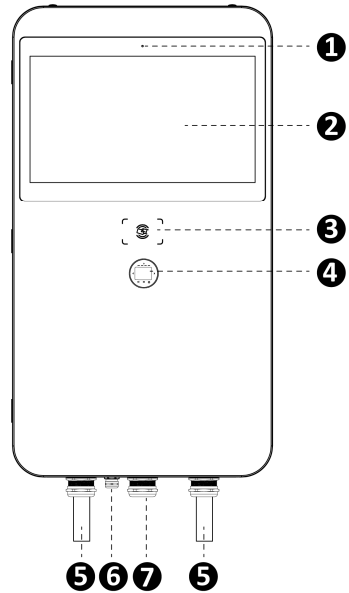

3.2 Product Overview (Inside)

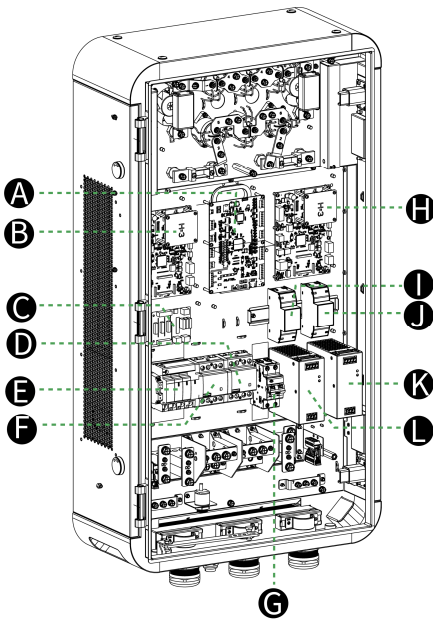

- A Equipment Control Unit
- B Communication Control Unit 1
- C Power Hub
- D AC Contactor (KM2)
- E Surge Protection Device
- F AC Contactor (KM1)
- G Residual Current Breaker with Over-Current (RCBO)
- H Communication Control Unit 2
- I Energy Meter (PJ1)
- J Energy Meter (PJ2)
- K 48 V Auxiliary Power
- L 24 V Auxiliary Power

3.3 Technical Specifications

Product Information

Power Rating

40 kW, max. 47 kW

Rated/Max. Input AC Current

75 A/82 A

Max. Output Current for Outlet A/B

- CCS2: 133 A
- CHAdeMO: 125 A

Outlet A+B

- CCS2 + CHAdeMO (charging for 2 EVs concurrently)
- CCS2 + CCS2 (charging for 2 EVs concurrently)

Network Type

TN-S, TN-C, TN-C-S, TT (Requires external RCD)

AC Input Connection

3P + N + PE

Overvoltage Category

AC side (Input) OVC: III

Power Factor (>50% load)

≥ 0.99

Cellular Communication

GSM, 4G, LTE

Charging Type

Mode 4

Input Voltage Range

400 VAC +10% ~ -10% @ 50Hz

DC Output Voltage

- CCS2: 150 to 950 VDC
- CHAdeMO: 150 to 500 VDC

Protection

Overcurrent, overvoltage, under-voltage, ground fault, over-temperature, short circuit, insulation monitor, surge protection

Total Harmonic Distortion (>50% load)

≤ 5%

Cable Length

5.5 m/7.5 m

Standby Power

40 W

Peak Efficiency

≥ 96%

Software Update

Software Update

OTA updates via web portal

General Characteristics

Enclosure Rating

IP54

Operating Altitude

< 2000 m (2000 m to 3000 m with power de-rating)

Storage Temperature Range

-40 °C to +70 °C

Dimensions (W x D x H)

550 x 265 x 1000 mm

Operating Temperature Range

-30 °C to +55 °C (+45 °C to +55 °C with linear power de-rating)

Mounting

Pedestal/trolley mount

User Interface

Status Indication

LED/APP

User Interface

- Autel Charge APP
- Autel Charge Cloud

Connectivity

- Wi-Fi
- Ethernet
- CAN
- RS485
- Cellular Network

Communications Protocols

- OCPP 1.6 JSON
- OCPP 2.0.1 (optional)

User Authentication

- QR Code
- RFID
- Plug & Charge
- Credit Card (optional)

Certification and Standards

EMC Compliance

Class A

Charging System

- IEC 61851-1
- IEC 61851-23
- IEC 61851-21-2

Certification

- CE
- UKCA

Communication to the EV

- ISO 15118
- DIN 70121
- CHAdeMO 1.2

Warranty

Base warranty 24 months after site acceptance test or 30 months after factory delivery. Warranty extensions available.

3.4 Product Dimensions

MaxiCharger

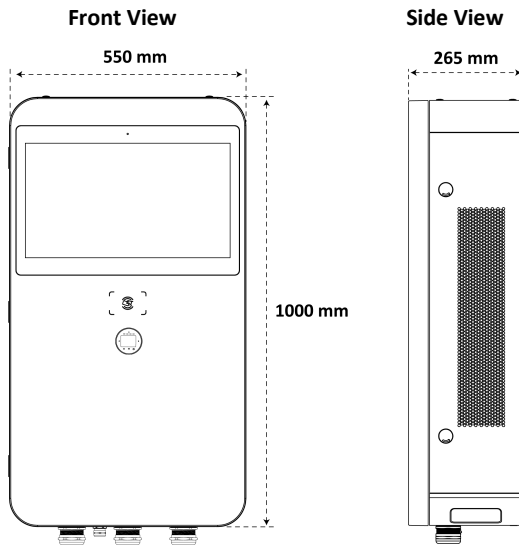

Pedestal

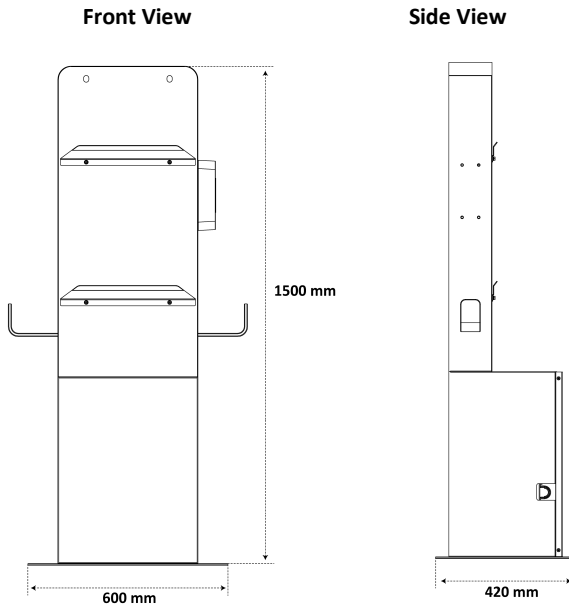

Trolley

Front View

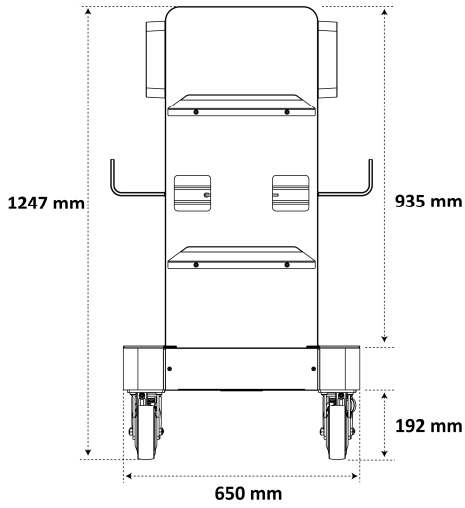

Side View

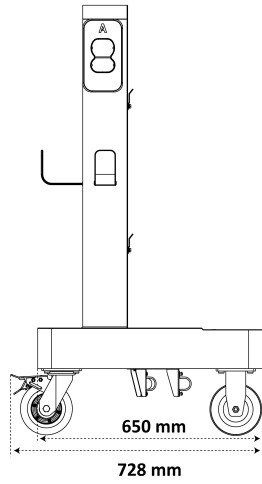

4 Preparation

4.1 Before You Begin

- Read through this manual prior to installation to familiarize yourself with the installation steps.
- Ensure the appropriate wiring, circuit protection, and metering are in place at the installation site, according to the specifications, wiring diagrams, and grounding requirements.
- Ensure the MaxiCharger is connected to a grounded, metal, permanent wiring system. Otherwise, an equipment-grounding conductor must be run with the circuit conductors and connected to the equipment grounding terminal or lead on the product.
- Ensure the installation site has a load capacity sufficient to support the MaxiCharger.
- If you choose to use a cellular network to communicate with the MaxiCharger, the cellular coverage at the installation site should be consistently strong. Use a cellular signal detection device to ensure the signal is above -90 dBm. If the signal is below -90 dBm, install repeaters to boost the strength of the cellular signal. Repeaters are often required when installing the MaxiCharger in underground environments such as in an underground garage or enclosed parking space.
- There is enough space available around the installation site to use a lifting equipment, to unpack, and to allow people to work freely.
- Ensure the charging connector of the MaxiCharger can sufficiently reach the vehicle's charging port with the chosen cable length. The standard charging cable length is 5.5 m, and 7.5 m is also available.

4.2 Installation Tools

- Flathead Screwdriver
- Hoisting Equipment
- Socket Wrench (8 mm/10 mm/13 mm/19 mm)
- Phillips Screwdriver
- Drill (16 mm)
- Brush
- Wire Stripper
- Cable Lug (Recommended: SC16-8)
- Voltage Tester
- Digital Multimeter

NOTE

- The tools mentioned above are not provided. Be sure to have all the tools prepared prior to the installation.
 - This tool list does not necessarily include all the tools you may need.
-

5 Installation

The MaxiCharger can be mounted on a pedestal or a trolley. The installation work shall be carried out after a suitable location is chosen.

! IMPORTANT

Always check local codes to ensure compliance. The guidelines described here are the minimum requirements. Ensure that the installation complies with all applicable codes.

5.1 Unpacking

1. Check the tilt and inversion indicators and shock watch.
 - Observe the sensors attached to the wooden box for the degree of the tilt and complete overturn. If the sensors demonstrate severe tilt (over 30°) or total overturn as shown, do not refuse shipment and note on bill of lading degree of tilt.

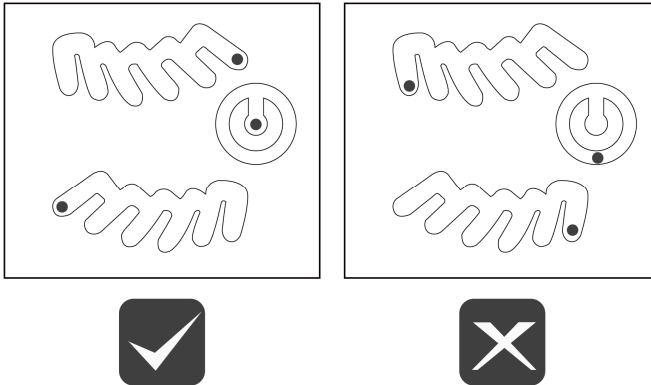

- If the shock watch appears red, do not refuse shipment and make notation on delivery receipt and inspect for damage. If damage is found, contact your local dealer.
2. Remove the packaging material using appropriate tools.
 3. Inspect whether the MaxiCharger and the parts for installation are damaged. If any damage is found or the parts are not consistent with the order, contact your local dealer.
 4. Make sure that all parts are delivered according to the order.

5.2 Moving the MaxiCharger

It is recommended to move the MaxiCharger to the installation site using an appropriate hoisting equipment (crane, straps, and so on).

1. Remove the four screws on the top of the charger using a flathead screwdriver. Set them aside.

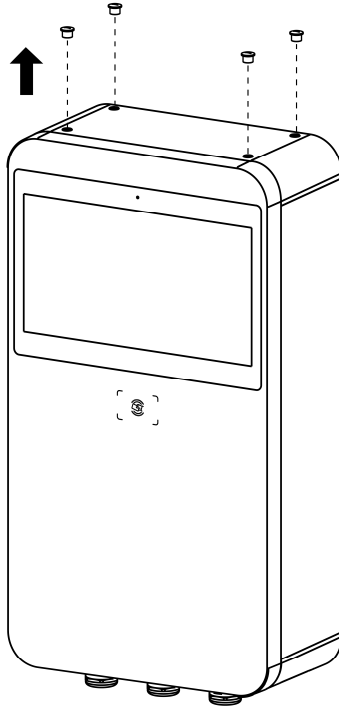

2. Install and tighten the four M12 lifting eye bolts into the four holes.
3. Connect the cables of the hoisting equipment to the eye bolts' lifting loops. **DO NOT** tilt over 45° when hoisting the MaxiCharger.
4. Move the MaxiCharger to the installation site.

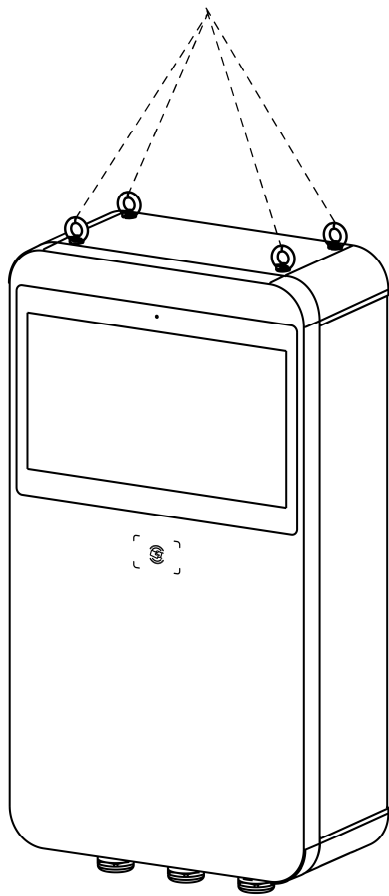

5.3 Installing the Pedestal-mounted MaxiCharger

The pedestal-mounted MaxiCharger can be shipped in the following two conditions:

- MaxiCharger and pedestal unassembled
- MaxiCharger mounted on pedestal

NOTE

- ◆ The “MaxiCharger and pedestal unassembled” means the MaxiCharger and pedestal will be shipped in separate boxes.
- ◆ The “MaxiCharger mounted on pedestal” means the MaxiCharger has been installed on a pedestal before shipment.

5.3.1 Location Requirements

The pedestal can be installed on an existing concrete. To safely mount the equipment, the concrete should be at least **80 mm** thick and its surface should be perfectly flat and level.

If a new foundation is required, prepare one according to the recommended dimensions (600 mm x 420 mm x 100 mm) (W x D x H).

NOTE



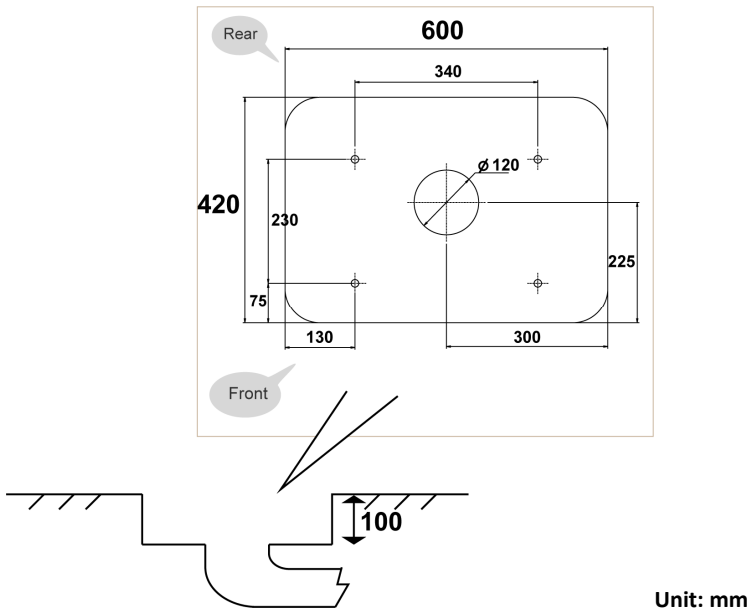



The foundation is recommended to be flush with the surface.



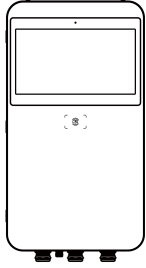

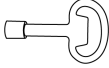

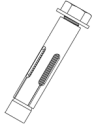
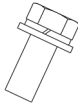
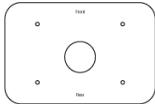
5.3.2 Checking the Package

Ensure the following items can be found in the package.

For MaxiCharger and pedestal unassembled:

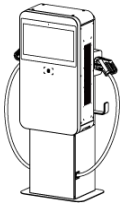
<p>MaxiCharger</p>		<p>Lifting Eye Bolt (M12) 4 PCS</p>	
<p>Triangle Socket Key 2 PCS</p>		<p>Hex Key (6 mm) 1 PC</p>	
<p>Pedestal 1 PC</p>		<p>Expansion Bolt (M12 x 80) 4 PCS</p>	
<p>Screw (M12 x 30) (2 PCS for spare) 4 PCS</p>		<p>Drilling Template 1 PC</p>	
<p>Torx Screwdriver (T25) 1 PC</p>			

For MaxiCharger mounted on pedestal:

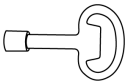
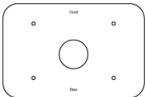
<p>Main Unit 1 PC</p>		<p>Lifting Eye Bolt (M12) 4 PCS</p>	
<p>Torx Screwdriver (T25) 1 PC</p>		<p>Hex Key (6 mm) 1 PC</p>	
<p>Expansion Bolt (M12 x 80) 4 PCS</p>		<p>Triangle Socket Key 2 PCS</p>	
<p>Drilling Template 1 PC</p>			

5.3.3 Getting Started

Step 1: Preparing the conduit

1. Trench and excavate a cable tunnel to accommodate the conduit. The outer diameter of the conduit must not exceed 120 mm.
2. The conduit stub-up should be minimum 100 mm.
3. Pull the conduit and wire up through the exit opening, leaving 600 mm flexible length for the remaining installation activities.

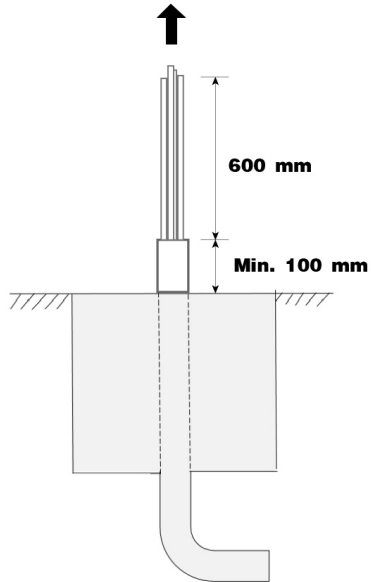

Step 2: Drilling holes

1. Place the drilling template on the concrete surface, aligning its central hole with the exit opening.

NOTE

The "Front" side of the drilling template must face forward.

2. Mark four holes on the concrete surface using a marker. Remove the drilling template.
3. Drill four holes at the marked positions measuring 16 mm in diameter and minimum 80 mm in depth.
4. Clean the dust.

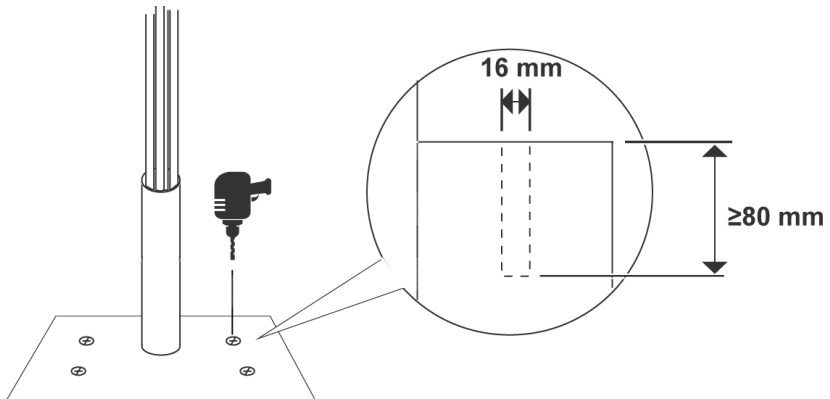

Step 3: Mounting a pedestal

1. Screw the four M12 x 80 expansion bolts into the drilled holes. Use a 19 mm socket wrench to remove the threaded bolts (C) and flat washers (B) when the expansion sleeves (A) are stuck. Set them aside.

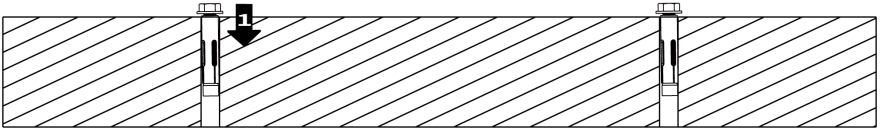
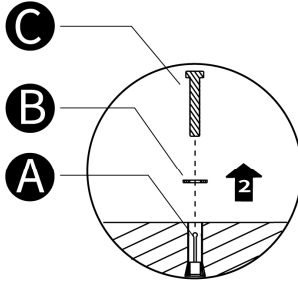

- Loosen the four M5 x 12 screws using the T25 Torx screwdriver to remove the front cover from the pedestal. Set them aside.

For MaxiCharger and pedestal unassembled:

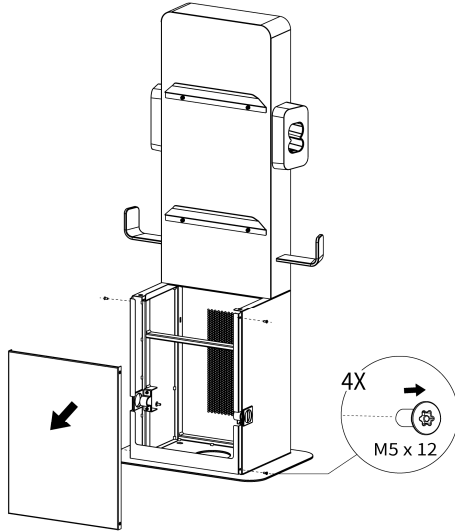

For MaxiCharger mounted on pedestal:

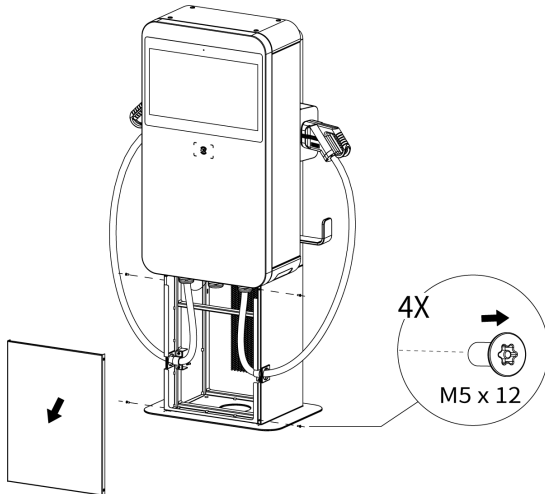

3. Place the pedestal/Lift the main unit (MaxiCharger mounted on a pedestal) onto the mounting location, aligning the central hole with the exit opening.
4. Reinsert the flat washers and threaded bolts in order and tighten them using a 19 mm socket wrench to 45–55 Nm.

For MaxiCharger and pedestal unassembled:

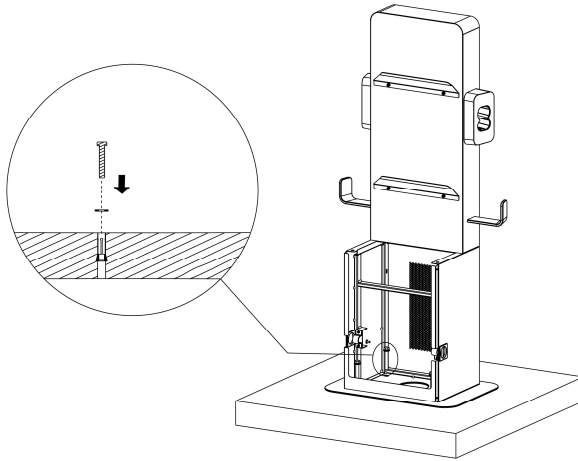

For MaxiCharger mounted on pedestal:

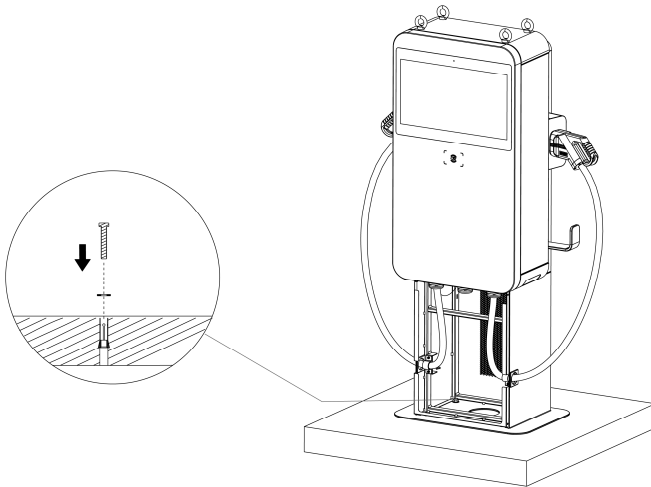

Step 4: Mounting the MaxiCharger

 **NOTE**

The MaxiCharger mounted on pedestal can skip this Step 4.

1. Lift the MaxiCharger onto the pedestal by the hoisting equipment. Position the groove (B) on the back of the MaxiCharger to fit the protrusion (A) of the pedestal as shown below. Ensure the charger is securely attached.

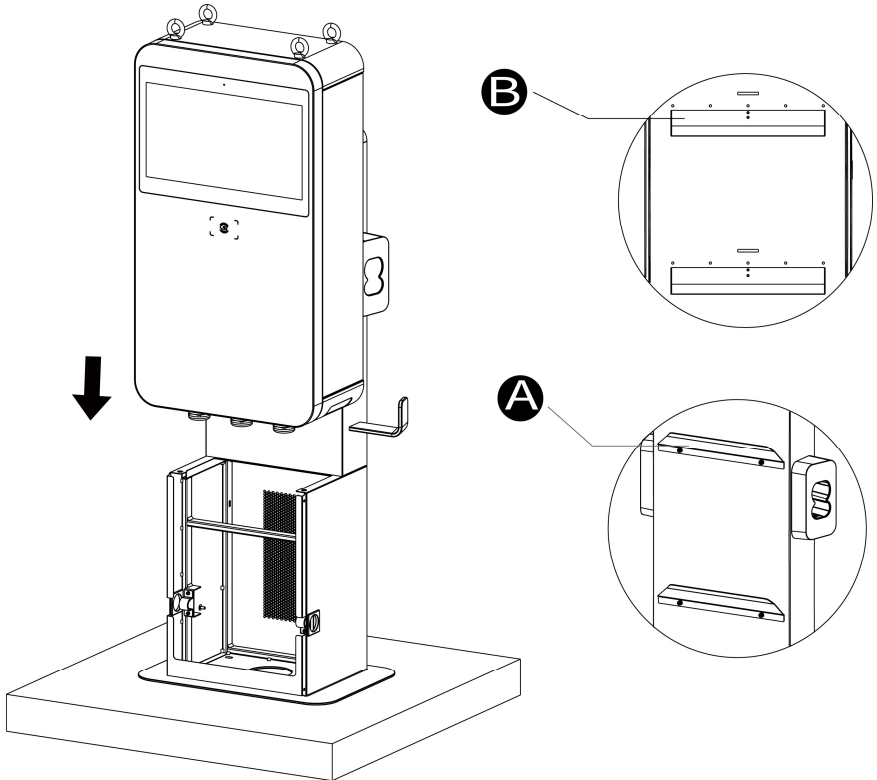

2. Insert and fasten the two M12 x 30 screws to the bottom holes (A) of the MaxiCharger using a 19 mm socket wrench to secure the MaxiCharger.

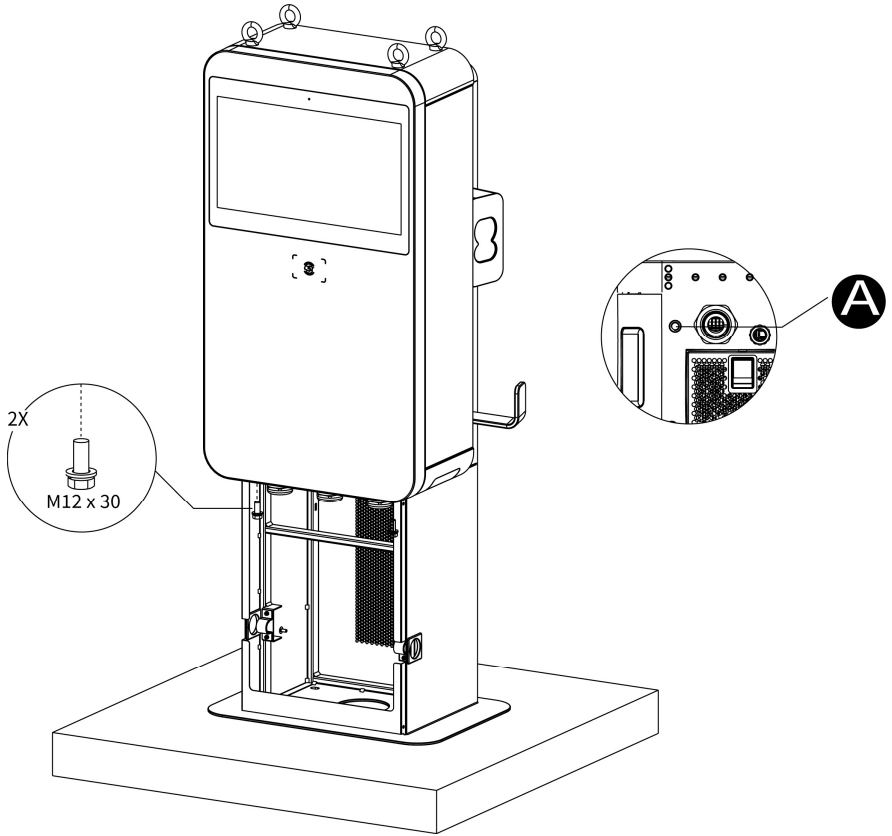

Step 5: Organizing the charging cable

1. Take down the rubber rings (A) from the pedestal and remove the two strain reliefs (B) by unscrewing the four M4 nuts using the Phillips screwdriver.

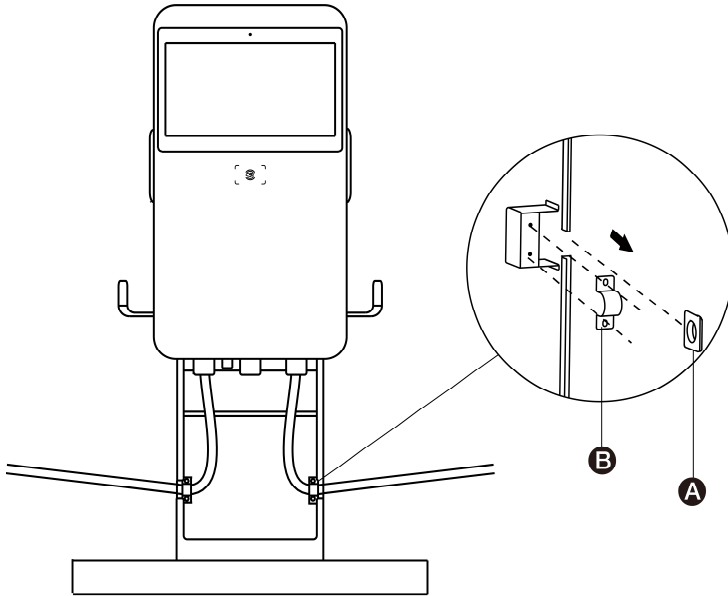

2. Use the strain reliefs to secure the charging cables by screwing the four M4 nuts and tightening them to 1.2 Nm.
3. Reinstall the rubber rings onto the pedestal letting the cables into the rubber rings via the openings. Ensure the charging cables are allowed to remain within its bending tolerance.
4. Drape the cables over the cable holders on both sides of the pedestal and plug the connectors into the holsters.
5. Remove the four lifting eye bolts and reinstall the top screws.

After the above installation steps are finished, you are ready to start power supply wiring. Please refer to **Section 5.5** to proceed.

5.3.4 Completing the Installation

1. Close and lock the front door by tightening the two M8 hex screws (A) using the hex key.

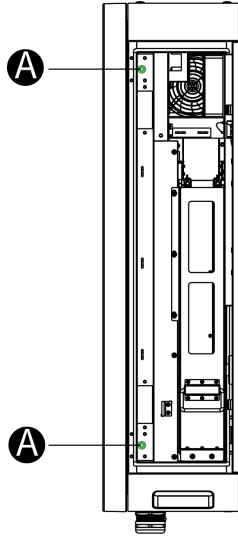

2. Close the side cover and turn the triangle socket key clockwise to lock the side cover.

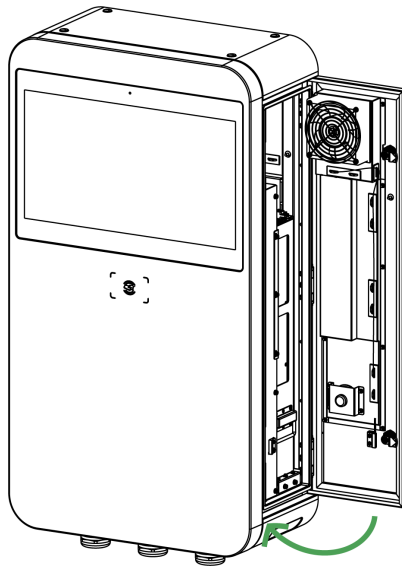

3. Reinstall the pedestal's front cover by screwing the four M5 x 12 screws and tightening them to 2 Nm.

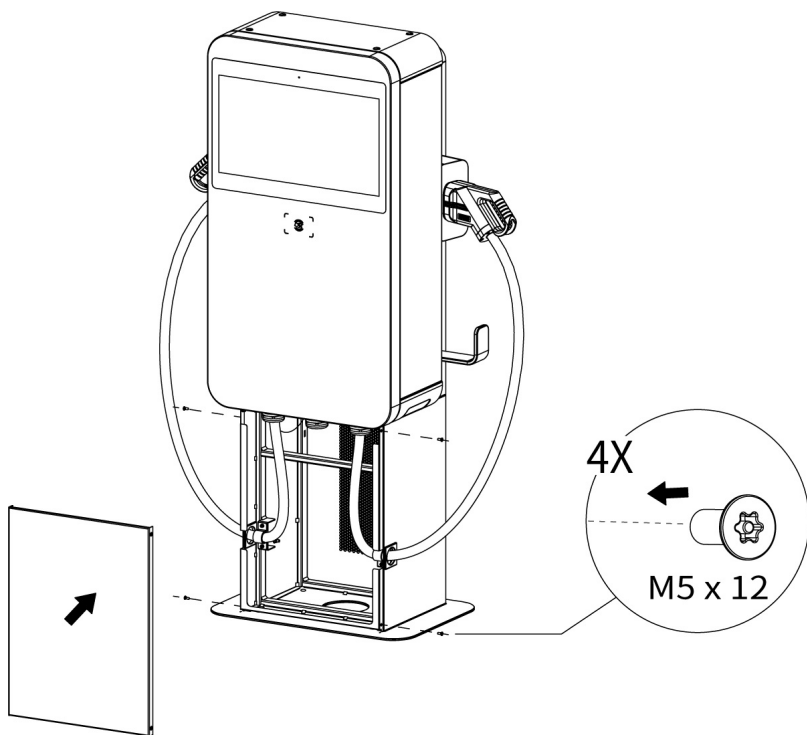

5.4 Installing the Trolley-mounted MaxiCharger

The trolley-mounted MaxiCharger can be shipped in the following two conditions:

- MaxiCharger and trolley unassembled
- MaxiCharger mounted on trolley





NOTE

- ◆ The “MaxiCharger and trolley unassembled” means that the MaxiCharger and trolley will be shipped in separate boxes.
- ◆ The “MaxiCharger mounted on trolley” means that the MaxiCharger has been installed on a trolley before shipment. **No mechanical and electrical installation is required.**

5.4.1 Checking the Package

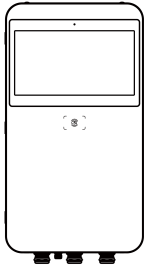

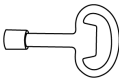
Ensure the following items can be found in the package.

For MaxiCharger and trolley unassembled:

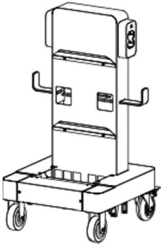
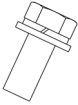
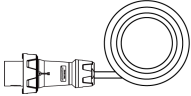
MaxiCharger 1 PC		Lifting Eye Bolt (M12) 4 PCS	
Triangle Socket Key 2 PCS		Hex Key (6 mm) 1 PC	

<p>Trolley 1 PC</p>		<p>Screw (M12 x 30) (2 PCS for spare use) 4 PCS</p>	
<p>Industrial Plug (with Cable) 1 PC</p>			

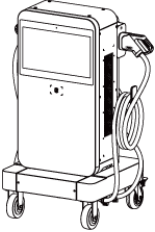
For the MaxiCharger mounted on trolley:

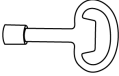
<p>Main Unit 1 PC</p>		<p>Hex Key (6 mm) 1 PC</p>	
<p>Triangle Socket Key 2 PCS</p>			

5.4.2 Getting Started

1. Use a Phillips screwdriver to loosen the four M5 x 12 screws to remove the front cover of the trolley. Set them aside.

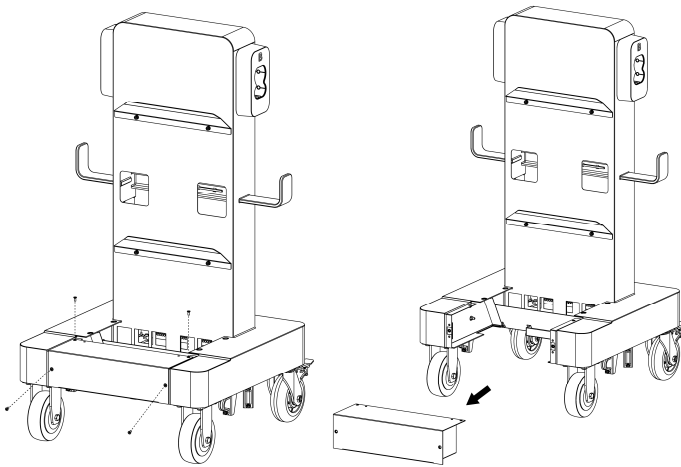

- Lift the MaxiCharger onto the trolley. Position the groove (B) on the back of the MaxiCharger to fit the protrusion (A) of the trolley as shown below. Ensure the MaxiCharger is securely attached. Remove the four lifting eye bolts and reinstall the top screws.

 **NOTE**

When lifting the MaxiCharger onto the trolley, press the foot brakes on the two rear wheels to prevent the trolley from movement.

- Insert and fasten the two M12 x 30 screws using a 19 mm socket wrench to secure the MaxiCharger.

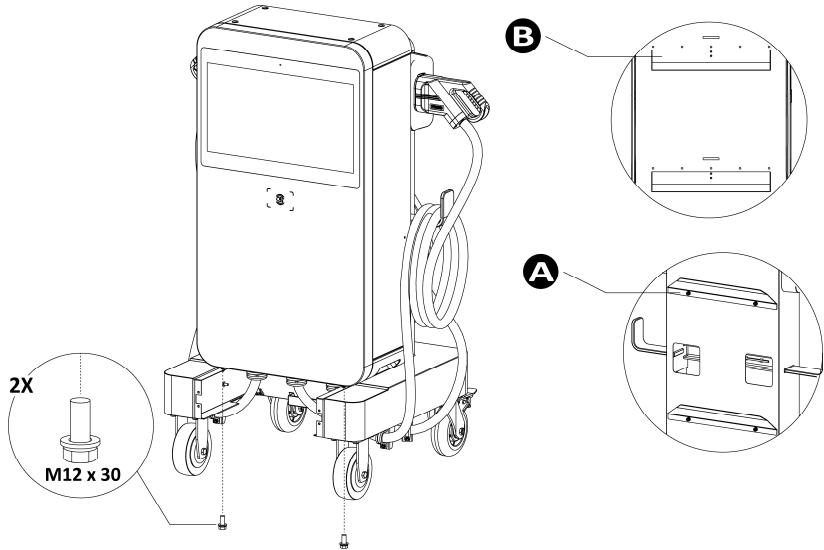

After the above installation steps are finished, you are ready to start power supply wiring. Please refer to **Section 5.5** to proceed.

5.4.3 Completing the Installation

1. Use the strain reliefs which have been installed on the trolley to secure the charging cable and AC input cable. Tighten the M5 nuts using an 8 mm socket wrench.
 - Use the smaller strain relief to secure the Phoenix charging cable.
 - Use the larger strain relief to secure the Amphenol charging cable.

 **NOTE**

The charging cable brand can be found on the charging connector.

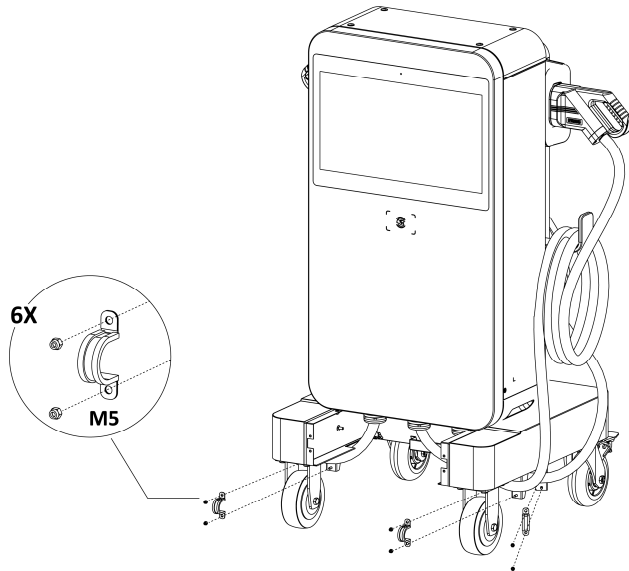

2. Reinstall the front cover of the trolley by inserting and tightening the four M5 x 12 screws.

3. Close and lock the front door by tightening the two M8 hex screws using the hex key.

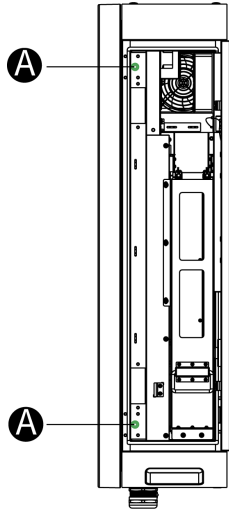

4. Close the side cover and turn the triangle socket key clockwise to lock the side cover.

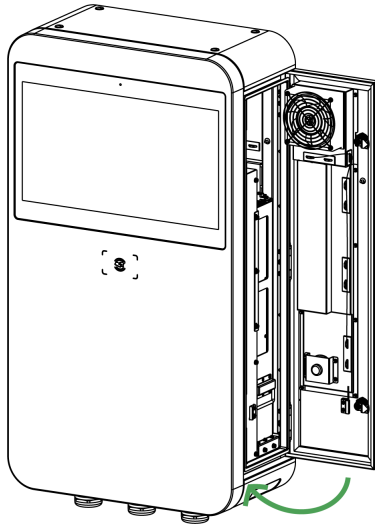

5. Drape the charging cables and industrial plug cable on the cable holders on the side and the rear respectively.

5.5 Power Supply Wiring

NOTE

The MaxiCharger mounted on trolley can skip this section.

WARNING

Risk of Electric Shock

- Only a qualified electrician should determine the electrical requirements and connect wires.
 - Ensure the power is off before connecting the wires.
-

IMPORTANT

Before connecting the wires, ensure the following requirements are met:

- Use 75 °C copper wire only.
 - The circuit breaker at the panel must be off.
 - The MaxiCharger must be grounded to true earth.
 - An insulated grounding conductor must be installed as part of the branch circuit that supplies the MaxiCharger.
 - The grounding conductor should be grounded to earth at the service equipment or, when supplied by a separately derived system, at the supply transformer.
 - All connections must comply with all local codes and ordinances.
-

5.5.1 AC Input Cable Information

MaxiCharger (kW)	Power Input Voltage	Rated Input Current	Wire Gauge Size	Cable Lug Size
47 kW	400 V	75 A	5 x 16 mm ²	SC16-8

5.5.2 Opening the Door

1. Shift the lock cover (A) on the right side of the MaxiCharger to one side, then insert the triangle socket key into the lock and turn it anti-clockwise to open the side door.

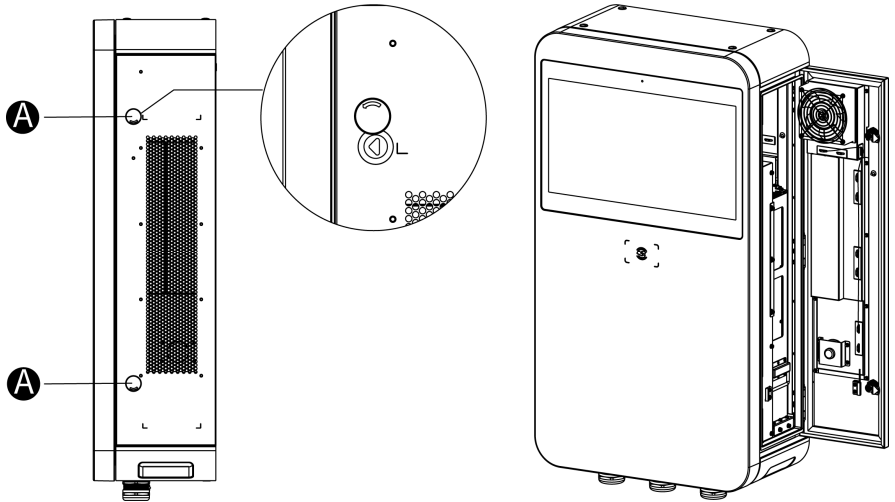

2. Loosen the two M8 hex screws (A) using the hex key and open the front door.

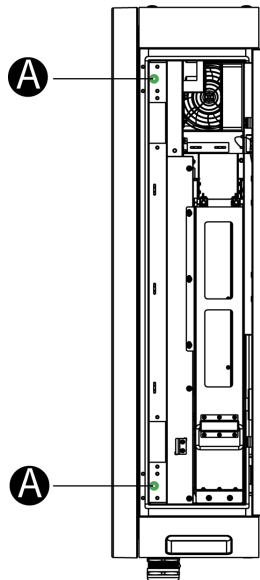

5.5.3 Connecting the AC Input Cable

NOTE

Connect the provided industrial plug (with cable) to the terminal block inside the MaxiCharger for the MaxiCharger and trolley unassembled. Follow the steps below to connect the industrial plug (with cable).

1. Loosen the five M6 x 16 screws using a Phillips screwdriver to remove the insulating barrier (A) and set them aside.

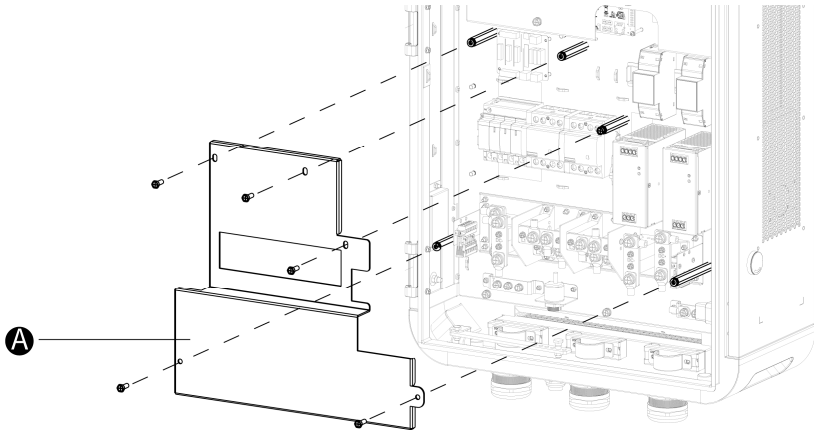

2. Pull the wires and guide them through the bottom AC inlet hole.
3. Use a wire stripper to remove an appropriate length of the insulation from the end of the wires. Ensure the stripped length is compatible with the cable lugs.
4. Use the crimping tool to attach the cable lugs to the end of the wires.

NOTE

The industrial plug (with cable) can skip the Step 3 and 4.

5. Loosen the M6 fastener using a 10 mm socket wrench and connect the PE wire to the PE busbar (**A**). Reinsert the fastener and tighten it to 6 Nm.
6. Use a 13 mm wrench to loosen the four M8 fasteners and attach the wires to the connectors:
 - L1 wire to the connector **B**
 - L2 wire to the connector **C**
 - L3 wire to the connector **D**
 - N wire to the connector **E**
7. Reinsert the M8 fasteners and tighten them to the torque 6–12 Nm.
8. Reinstall the insulating barrier.

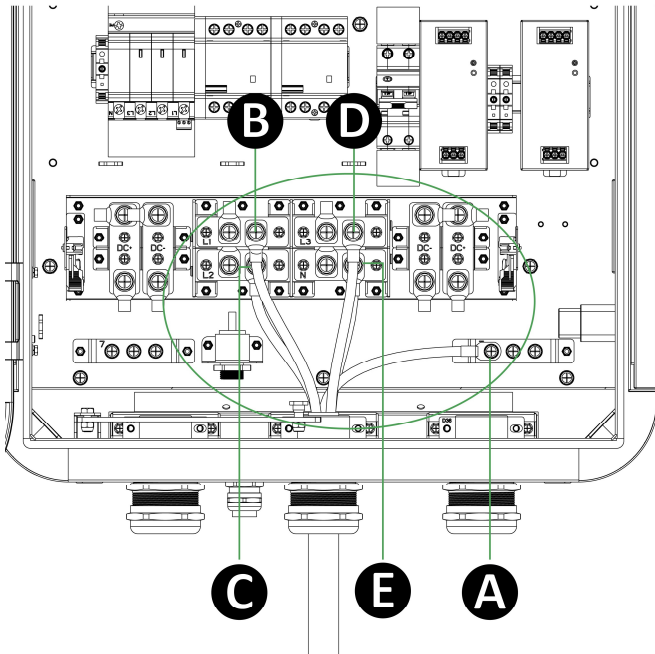

5.6 Connecting to the Internet

The MaxiCharger can access the Internet via Ethernet Cable, Wi-Fi or cellular network. The installation process vary among different Internet connections. Select the optimal method to connect the Internet and follow the steps below accordingly.

5.6.1 Via the Ethernet Cable

 **NOTE**

For trolley-mounted MaxiCharger, cellular data or Wi-Fi is preferred to access the Internet for movability.

1. Loosen the cable gland (A).
2. Put the Ethernet cable through the Ethernet cable port at the bottom of the MaxiCharger.
3. Plug the Ethernet cable into the RJ45 port.
4. Tighten the cable gland (A).

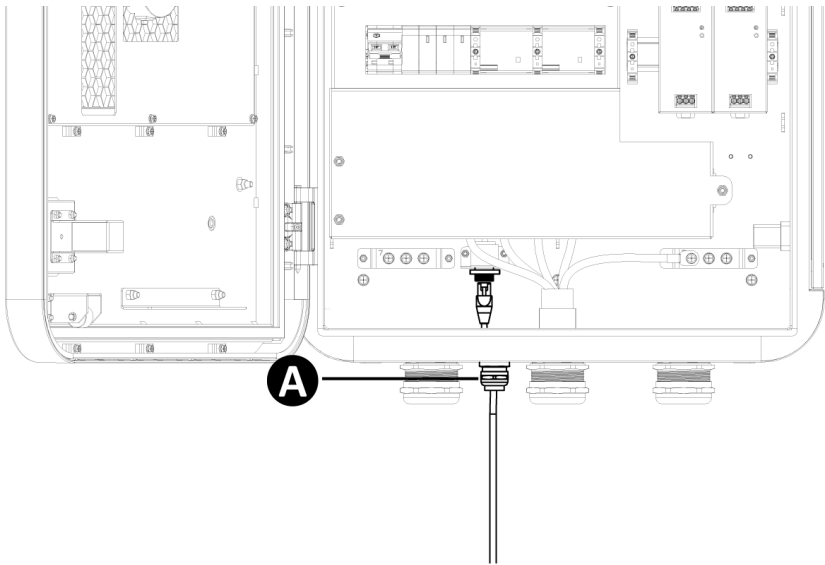

5.6.2 Via the Cellular Network

1. Press the button (A) to release the SIM card tray.
2. Insert a SIM card into the tray. Ensure the card is placed correctly.
3. Push the SIM card tray into the slot.

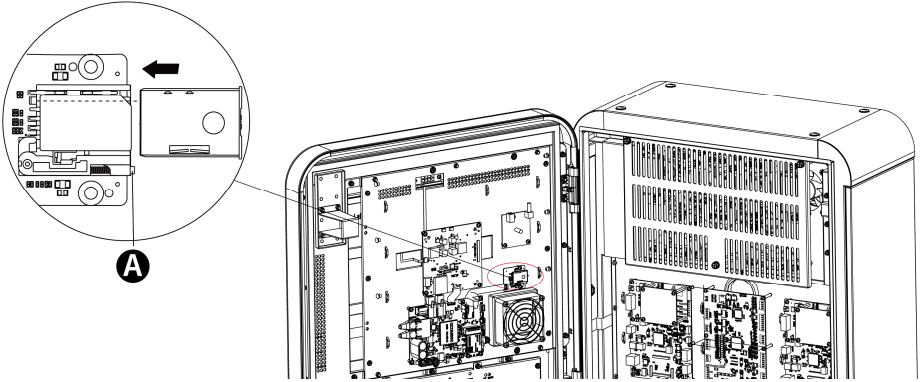

5.7 Installing the Upstream Protective Device

Devices	Specifications
Dedicated upstream protection device(s)	Options: <ul style="list-style-type: none">● RCD (Type A) + MCB● RCBO (Type A)
Upstream overcurrent protection breaker, such as RCBO or MCB (The breaker serves as the main disconnect switch to the MaxiCharger.)	Breaker rating should be at least 80 A. Recommended: 100 A. Refer to your local rules for breaker rating. Tripping characteristics: type C
Upstream residual-current device (RCD)	Type A, with a rated residual operation current of 30 mA

5.8 Connecting the Industrial Plug to the Socket

! IMPORTANT

Before unplugging the industrial plug after the charging session is finished, cut off the power first.

This section applies for trolley-mounted MaxiCharger. The industrial plug connection steps are as below:

1. Open the socket cover.
2. Insert the industrial plug into the socket and fully push the plug.
3. Rotate the bayonet ring (A) clockwise to secure the connection.

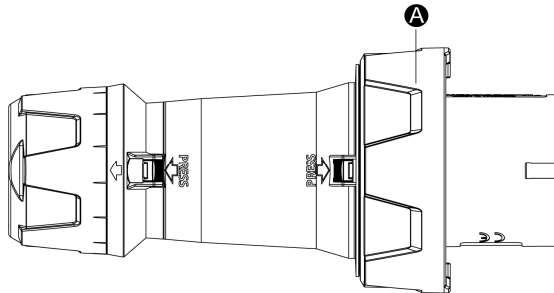

4. Turn on the local service panel switch to supply the power to the MaxiCharger.
5. Unplug the industrial plug after the charging session is completed.

6 Operation

Ensure all the installation and wiring are secured and correct, then power on the MaxiCharger.

CAUTION

- Do not touch the inside components of the MaxiCharger while it is powered on.
- Operate the MaxiCharger only when its door is closed and locked.

NOTE

In the event of ambient temperature lower than -20 °C, it will take 3–5 minutes for the touchscreen to display when powering on the MaxiCharger. In extreme cases, the display module will be reset to ensure the stability of the MaxiCharger.

6.1 Charging Procedure

General charging procedures:

➤ To charge an EV

1. Park an EV with the charging port within reach of the connector.
2. Plug in the EV.
3. Start the charging session.
4. Stop the charging session.

WARNING

- Do not cover the vent during charging.
- Do not clean or operate in the EV during charging.

6.1.1 Standby Mode

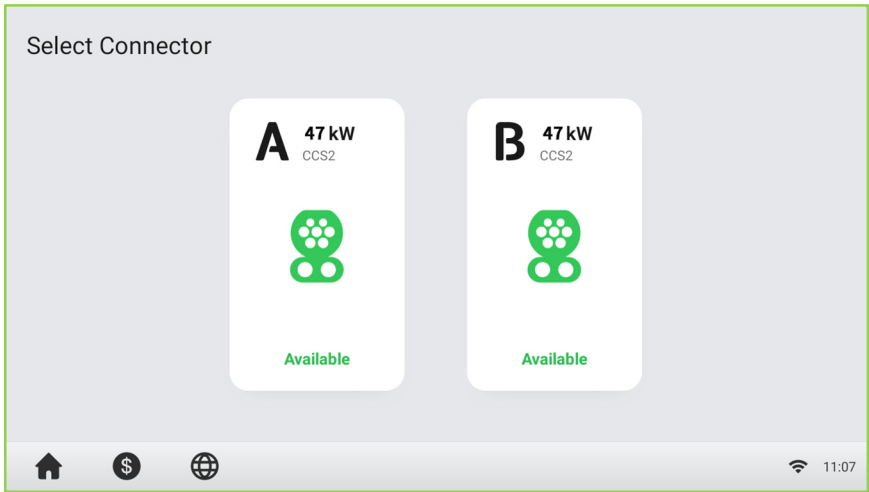

After a connector is successfully connected to your EV, the MaxiCharger can automatically recognize the connector, then the corresponding connector's Authorization Screen will appear.

If no operation is performed for a long time on the Authorization Screen, the Standby Screen will appear. Manually select the appropriate connector on the touchscreen.

6.1.2 Authorization

! IMPORTANT

- Observe the screen for any abnormalities, such as an error messages, before starting a charging session. Check the surroundings and the MaxiCharger for any abnormalities and damage as well.
- If the screen displays an error message, **DO NOT** use the MaxiCharger. Contact Autel Technical Support.

When the Authorization Screen appears, you can use any of the following methods to start a charging session.

- Scan the QR code on the screen
- RFID card
- Plug & Charge
- Credit card (optional)

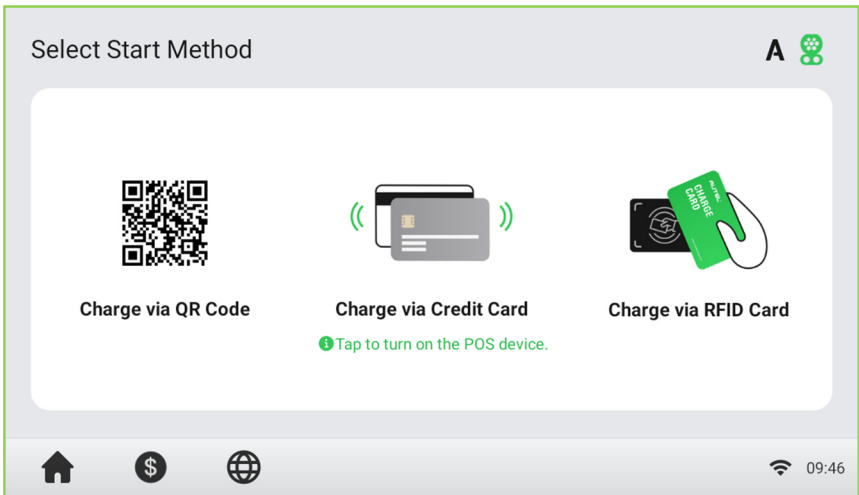

6.1.3 Start Charging

After authorization, the MaxiCharger will set up communication with your EV and necessary safety tests will be performed. Following the safety tests, the charging session will start automatically.

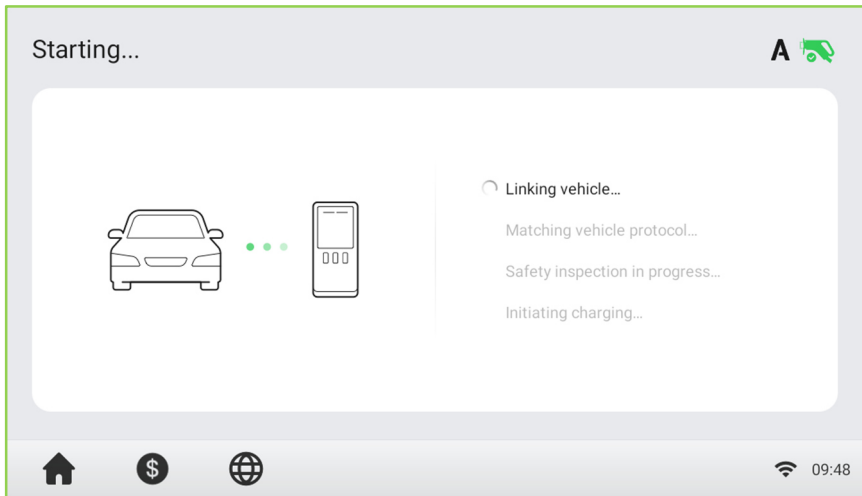

6.1.4 Charging

You will be informed of the progress during charging. Information about the charging duration, energy, cost, and power will appear on the Charging Screen.

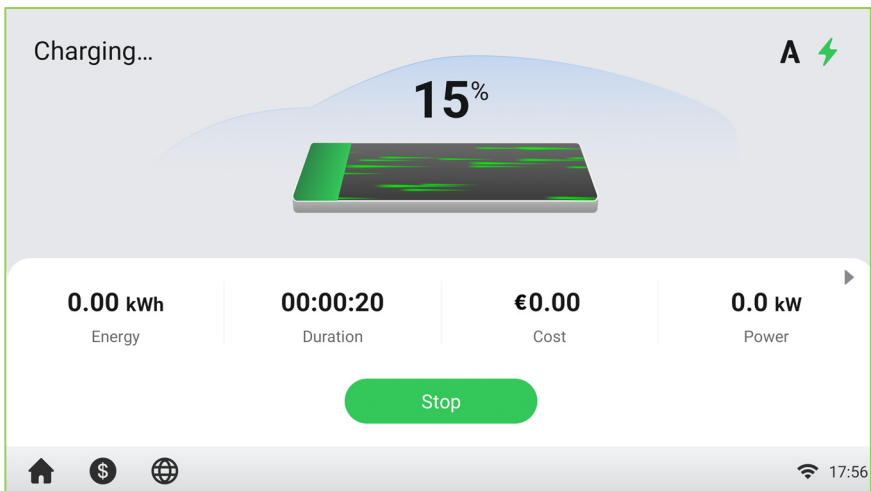

6.1.5 Stop Charging

➤ To stop charging

1. Tap the **Stop** button on the screen.

NOTE

When the battery is full, the charging session stops automatically.

2. Normally, you have to authorize again to finish charging, using the same authentication method as was used to start:
 - QR code: Scan the QR code with the Autel Charge app and tap the **Stop** button on the Charging Screen of the Autel Charge app.
 - RFID card: Put the RFID card on the card reader again to finish charging.
 - Credit card: Finish charging directly.
3. When charging is finished, your transaction details will appear.

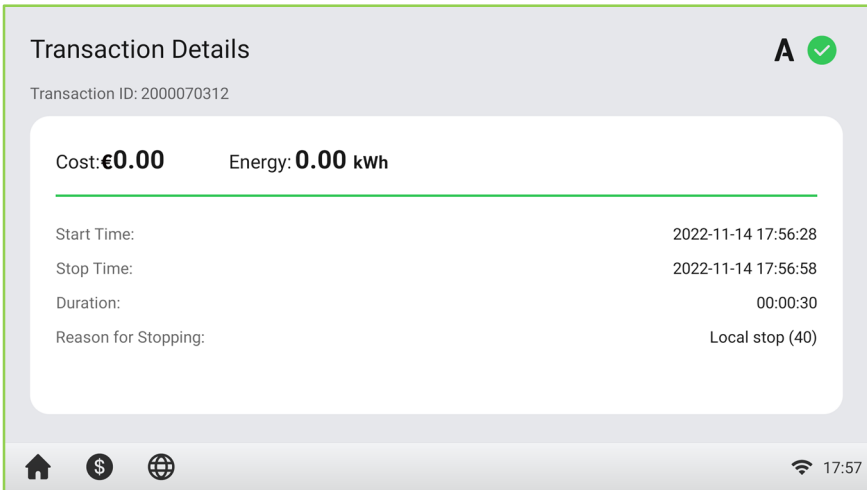

4. Disconnect the EV charging cable from the EV.

6.1.6 Finish Charging

Return the connector to the holster on the MaxiCharger.

6.2 Charging Errors

This section depicts several common problems that may arise during your charging session, along with possible causes/solutions to help you resolve those problems. If the problem persists, contact your local dealer or Autel Technical Support.

6.2.1 Connector Connection Error

If the connector is not properly connected to your EV, then the Connector Not Connected screen will appear. Insert the connector into your EV's charge port and check the connection.

6.2.2 Authorization Failure

If an error occurs when you start the authorization process but without starting charging, the Authorization Failure screen will appear. The cause and possible solution(s) will display on the screen. Follow the on-screen instructions to resolve the problem, or contact your local dealer or Autel technical support.

6.2.3 Charging Start Failure

If an error occurs when you start charging, the Charge Start Failure screen will appear. The cause and possible solution(s) will display on the screen. Follow the on-screen instructions to resolve the problem.

6.2.4 Charging Failure

If an error occurs during charging, the Charging Failure screen will appear. The cause and possible solution(s) will display on the screen. Follow the on-screen instructions to resolve the problem, or contact your local dealer or Autel Technical Support.

6.3 Emergency Stop Response

When detecting emergency stop signal sent from the EV during charging, the MaxiCharger will immediately stop DC output. As a result, the voltage and current will be dramatically reduced to 60 V and 5 A in 30ms. The DC output contactor will also be disconnected. After this charging session is finished, the MaxiCharger will return to normal.

6.4 Powering down the MaxiCharger

1. Set the upstream breaker which provides the power to the MaxiCharger to **OFF** and lock it. Make sure that this breaker stays in the **OFF** position during the procedure.
2. Open the front door.
3. Measure the AC voltage by referring to [Measuring the AC Voltage](#). Make sure that all the measured voltages are 0 volt.
4. Measure the DC voltage by referring to [Measuring the DC Voltage](#). Make sure that all the measured voltages are 0 volt.
5. Close the front door.

6.4.1 Measuring the AC Voltage

Use a voltage tester to measure the AC voltage between the terminals on the surge protection device switch:

- L1 to L2
- L1 to L3
- L2 to L3
- N to L1/L2/L3

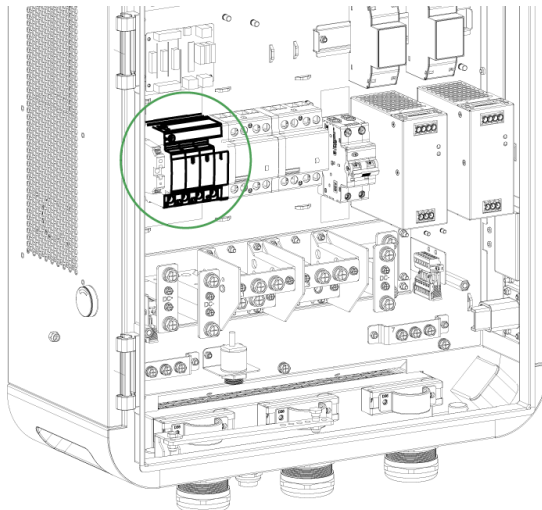

NOTE

The surge protection device switch shows the indications N, L1, L2, and L3.

6.4.2 Measuring the DC Voltage

Use a voltage tester to measure the DC voltage between the output terminals, making sure that all the measured voltages are 0 volt.

- Power module group output 1- (A) to power module group output 1+ (B)
- Power module group output 2 - (C) to power module group output 2+ (D)
- EV charging cable 1 output - (E) to EV charging cable 1 output + (F)
- EV charging cable 2 output - (G) to EV charging cable 2 output + (H)

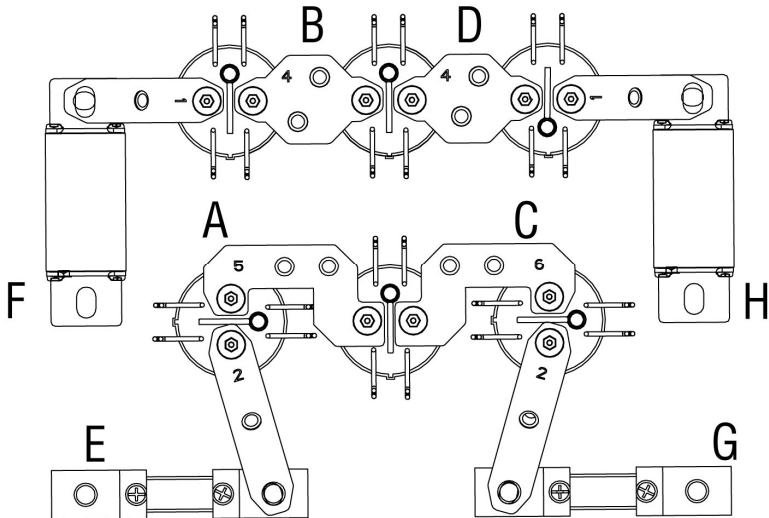

6.5 Local Service Portal Operations

6.5.1 Setting the OCPP Parameters

 **NOTE**

The OCPP parameter setting should be performed by an installation engineer.

➤ **To set the OCPP parameters**

1. Double tap the upper-left corner of the screen.
2. Tap **Device Maintenance**. Enter the default password to continue. **The password is the last 6 digits of the S/N number shown in the product label.**
3. Tap **Set Parameters**. Wait for the system to load the data. This can take a few seconds.
4. Set the following parameters:
 - **Running environment**: current running environment
 - **OCPP IP**: IP address of the OCPP
 - **OCPP URL**: URL of the OCPP
 - **OCPP PORT**: port number of the OCPP
 - **MGR IP**: IP address of the management platform
 - **MGR URL**: URL of the management platform
 - **MGR PORT**: port number of the operational management platform

 **NOTE**

Make sure that the URL or ID you type is correct and without spaces.

5. Tap **Save** to save your changes.

6.5.2 Configuring the Cloud Platform

Configuring the cloud platform is also needed for the charger. The MaxiCharger supports Autel or a third-party cloud platform. The Autel Charge Cloud, a one-stop charging management solution, is intended to address the needs of many use-cases including commercial, residential, governmental, car dealers, and fleets. Contact Autel technical support for subscription and learn more details on Autel Charge Cloud manual.

If a third-party cloud platform is used, contact the third-party personnel for configuration.

7 Maintenance

7.1 Routine Maintenance

Routine maintenance can keep the MaxiCharger in safe and stable state.

- Clean the MaxiCharger every quarter: tighten the screws and bolts of key parts, and check whether the wire connection of the MaxiCharger's connector is burned out. If any abnormality is found, replace the parts promptly.
- Clean the filter at least twice a year.
- Test the residual current device once a year.

WARNING

- Disconnect the power supply to the MaxiCharger during the entire maintenance procedure.
- Make sure that unauthorized personnel are kept at a safe distance during maintenance.
- Wear proper personal protective equipment, such as protective clothing, safety gloves, safety shoes, and safety glasses.
- If you remove the safety devices for maintenance, reinstall them after completing the work.

7.1.1 Residual Current Device Maintenance

WARNING

Be careful when you work with electricity.

The internal residual current breaker with overload (RCBO) should be tested annually for correct functioning. Before testing, disconnect the MaxiCharger with the EV and stop any charging processes.

To test the RCBO

1. Open the front door of the MaxiCharger. When the cabinet door is opened, the MaxiCharger should not be directly exposed to wind and rain.
2. The MaxiCharger must be in Standby mode. Tapping the touchscreen will wake up the MaxiCharger.
3. Locate the RCBO, and press the **Test** button to start the test.
 - Pass: The RCBO will trip and restore the **Test** button to its original position.
 - Fail: The RCBO does not trip. Please contact Autel technical support. Do not use the MaxiCharger until the repair is completed.
4. Close the front door after the test is finished.
5. Mark the time when the test is needed to be repeated annually.

7.1.2 Cleaning the MaxiCharger

The MaxiCharger is powder-coated. The coating must be kept in good condition. When the MaxiCharger is in a corrosion sensitive environment, superficial rust may appear on welding points. Visible rust has no risk to the integrity of the MaxiCharger.

➤ To remove rust

1. Stop any charging processes and power off the MaxiCharger.
2. Remove rough dirt by spraying with low-pressure tap water.
3. Apply a neutral or weak alkaline cleaning solution and let it soak.
4. Remove dirt by hand with a damp and non-woven nylon cleaning pad.
5. Rinse thoroughly with tap water.
6. Apply wax or a rust-preventive primer for extra protection if needed.

WARNING

- Before cleaning, stop any charging processes and do not connect the power to the MaxiCharger. Failure to do so may cause damage and/or personal injury or death.
- Do not apply high-pressure water jets and avoid water leaking into the MaxiCharger. Make sure that the inside of the MaxiCharger is dry during cleaning.
- Do not use caustic solvents, sprays, solvents or abrasives. Use cleaning agents with a pH between 6 and 8 for strong stains only.

7.1.3 Cleaning and Replacing the Filter

WARNING

- Before cleaning, stop any charging processes and do not connect the power to the MaxiCharger. Failure to do so may cause damage and/or personal injury or death.
- Do not apply high-pressure water jets and avoid water leaking into the MaxiCharger. Make sure that the inside of the MaxiCharger is dry during cleaning.
- Do not use caustic solvents, sprays, solvents or abrasives.

The MaxiCharger is equipped with a filter with a large mesh area to prevent the electronic components from being damaged by dust. Clean the filter every 3 months (not to exceed 6 months). Replace the filter annually.

➤ **To clean or replace the filter**

1. Before cleaning and replacing, be sure to stop all charging processes, disconnect the external power supply, and perform the power-off protection.
2. Open the two toggle latches (A) at the bottom of the MaxiCharger to flip the bezel (B) downward.
3. Remove the filter (C).
4. Clean debris or dust of the filter and reinstall a cleaned filter. Alternatively install a new air filter.
5. Flip the bezel (B) upwards and close the two toggle latches (A).

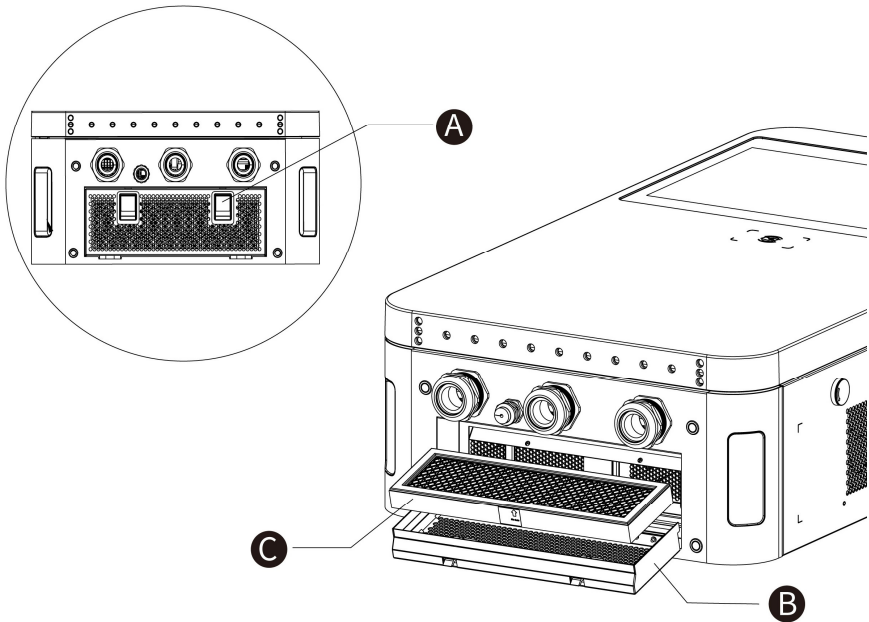

7.2 Inspection and Maintenance

When the MaxiCharger operates normally, only routine maintenance is needed.

When the MaxiCharger operates abnormally, refer to [Troubleshooting](#) to resolve the problem or contact your local dealer or Autel Technical Support promptly.

When parts need to be replaced, completely cut off the power supply upstream and inside the equipment before operating.

Regularly conduct a visual inspection of the following points:

- Cable and connector: Check for cracks or ruptures on the connector or cable.
- Display: Check for damage and cracks. Check whether the touchscreen works.
- MaxiCharger coating: Check for damage, cracks or ruptures.
- MaxiCharger: Check for rust or damage.

The following special inspections are needed for safe use:

- Check if the MaxiCharger was struck by lightning.
- Check if the MaxiCharger was damaged due to an accident or fire.
- Check the MaxiCharger installation site has been flooded.



WARNING

Stop any charging processes and do not connect the power to the MaxiCharger until all the inspections are complete.

7.3 Remote Maintenance

The MaxiCharger has the function of connecting to cloud platform to monitor parameters in real time. This provides remote upgrades, remote diagnosis, and remote service functions, and can timely identify and locate problems in the operation process.

- System self-check for abnormality daily.
- If any operation abnormality is found, contact your local dealer or Autel technical support promptly.
- Autel service engineers can check logs, update configurations and programs, and provide remote maintenance services, such as remote management, diagnosis, configuration, and upgrades.

7.4 Maintenance Schedule

Item	Frequency	Actions
Connector	Every 3 months	Check for cracks or ruptures on the connector.
Input Cable	Every 3 months	Check for cracks or ruptures on the cable.
Filter	Annually	Replace the filter.
MaxiCharger	Every 3 months	Clean and check for damage.

8 Troubleshooting and Service

8.1 Troubleshooting

The table below describes the most common faults when operating the MaxiCharger. Contact Autel technical support if the fault encountered is not in this table.

Error	Error Code	Possible Cause	Solution
CP voltage abnormal	0x2037	It may be caused by signal interference, poor contact or software errors.	Perform remote restart or reset. If the fault persists, contact Autel technical support.
Communication error with the entire charging module group	0x3011	There is a problem with the module's address setting.	Power off the MaxiCharger and restart it.
Overvoltage	0x202D	The DC output voltage is above the upper limit of the vehicle or the rated voltage of the MaxiCharger during charging.	Stop the charge session and contact Autel technical support.
Communication error with the power control module	0x200E	The CCU does not receive messages from the ECU and the communication is timed out.	Perform remote restart or reset. If the fault persists, contact Autel technical support.
BMS communication error	0x2007	It may be caused by charging incompatibility.	Perform remote restart or reset. If the fault persists, contact Autel technical support.
Cooling fan abnormality	0x304A	Fan aged or damaged.	Power off the MaxiCharger and contact Autel technical support for repair or replacement of the fan.

Error	Error Code	Possible Cause	Solution
Charging port electronic locking fault	0x2002	It might be caused by a vehicle-related fault.	Contact the vehicle manufacturer and Autel technical support.
CCU auxiliary power supply shutdown	0x202C	Sever power fault due to aged key components or lines.	Power off the MaxiCharger. Then locate the faulty component or line and contact Autel technical support for its repair or replacement.
Meter communication error	0x0001	Aged meter or line.	Stop the charge session and contact Autel technical support.
Insulation monitoring fault	0x2003	If it appears from time to time, it might be due to the vehicle or software error; if it appears frequently, there may be an aged key component.	Perform remote restart or reset. If the fault persists, contact Autel technical support.
AC contactor stuck	0x3008	AC contactor fault or line aging	Power off the MaxiCharger and contact Autel technical support.
FPGA fault	0x3010	Controller fault	Stop the charge session, power off the MaxiCharger, and contact Autel technical support.
CCU current sampling and module output current accumulation fault	0x3014	Charging module output or sampling fault	Perform remote restart or reset. If the fault persists, contact Autel technical support.
Power distribution contactor sticking (charging possible)	0x3047	Contactor or sensor fault or line aging	Power off the MaxiCharger immediately and contact Autel technical support.

Error	Error Code	Possible Cause	Solution
Communication error on one charging module	0x3051	Abnormal charging module	Contact Autel technical support to identify the fault, and then clear the fault or replace the module.
Fan fault with one charging module	0x305A	Abnormal charging module	Contact Autel technical support to identify the fault, and then clear the fault or replace the module.
Inconsistent CCU voltage sampling and the module output voltage	0x305C	Abnormal charging module	Contact Autel technical support to identify the fault, and then clear the fault or replace the module.
Insulation detection alert	0x2040	If it is a one-time problem, there is may be a falling object, and no operation is required; if it has occurred for several times, the connector cable may be damaged or there are foreign objects in the busbar.	Power off the MaxiCharger immediately and contact Autel technical support.
Charger offline	0x9001	Communication error between gateway and the Autel Charge Cloud	Check the network connection and OCPP configurations.

8.2 Service

If you cannot find solutions to your problems with the aid from the table above, please contact Autel Technical Support.

AUTEL Europe

- **Phone:** +49(0)89 540299608 (Monday–Friday, 9:00 AM–6:00 PM Berlin Time)
- **Email:** evsupport.eu@autel.com
- **Address:** Landsberger Str. 408, 4. OG, 81241 Munich, Germany

AUTEL[®]
www.autelenergy.com